

Print Post Publication No. PP326342/0008

DIESEL TORQUE



**Official Magazine of the Association of
Australasian Diesel Specialists Inc.**

EDITION FORTY

DECEMBER, 1994



Walz Diesel Fuel Injection

A division of Atkins Carlyle Ltd. (Incorporated in W.A.)

A.C.N. 008 666 064

SALES & SERVICE

Fuel Injection Pumps • Governors
Electric Governors • Injectors • Turbochargers

Australian Distributors for —

STANADYNE®
Diesel Systems

AMBAC
INTERNATIONAL

*Authorised Distributors and
Service Dealer for —*

Bosch, Zexel,
Nippon Denso,
Lucas, Stanadyne
K.K.K. Turbochargers
N.S.W., Qld., Vic.

Authorised Distributors for —



MEMBER

ADS
ASSOCIATION OF
DIESEL SPECIALISTS

Phone: (02) 755 1422

48-50 Alfred Road, Chipping Norton, 2170 N.S.W.

Fax: 724 6961

ND NIPPONDENSO

Suppliers of Original Diesel Equipment to the Leading Manufacturers

TOYOTA



Hino



YAMAHA



ND NIPPONDENSO

DIESEL INJECTION EQUIPMENT

As a manufacturer of Diesel Injection Equipment, Nippondenso has enjoyed the patronage of the major manufacturers in Japan for many years. Our aim is to consistently supply these manufacturers

with products of the highest quality and technological level possible. In order to maintain this quality, which is now demanded by the customer, always repair Diesel Equipment with Genuine Diesel injection Components.

ND NIPPONDENSO

A.C.N. 004 938 621

NIPPONDENSO (AUSTRALIA) PTY LTD.
Kororoit Creek Road, Altona, Victoria, 3018

EDITORIAL

As the association enters a new phase of its existence, with the formation of the Board of Management, consisting of the president, the chairperson of each branch and the executive officer, some fundamental issues will need to be addressed if these structural changes are to be successful.

After twenty odd years of operation, most of the people who have or still hold office are finding it difficult to devote the time and dedication to the job that they started with. Many of them have either reached retirement or their businesses have grown to a stage where they can no longer put in the hours necessary to come up with new ideas and carry out the work to continue the associations growth and viability. This means that the time has come for the younger members to take up the challenge and stand for office and ensure the continued growth of the association in the directions they want it to head. If they don't come forward and accept this responsibility, there will be no association and the industry will slip back into the dark ages prior to the formation of AADS.

Another area of concern is with the OEM and manufacturing members. They are a necessary and vital link in the association aspirations. They must offer technical and practical assistance to all service members and not just the chosen few. All service members are their customers, for equipment and spare parts and to the best of their ability service the complex array of product in the market place. Warranty is the responsibility of the OEM and it is their right to appoint the people they want to carry out this service to their customer and the association has no problem with these appointments, but for the good name of the OEM products it is essential that all service members are given access to the training and information to service these products.

To complete the full circle of these concerns, each service member must realise their responsibilities and make every effort to keep premises, equipment and tools up to date, to support the OEM and AADS training schools. To support each other and not to denigrate another members work. To support the OEM and use genuine parts at all times. To charge a responsible service fee which will enable them to afford the ongoing upkeep and replacement of tools and equipment.

So how about it? Where do you fit into the scenario and can you accept the challenge to keep the association strong and viable at all levels of membership. The future is in your hands.

To everyone, I thank you for your support of Diesel Torque during 94 and I wish you all a very happy and safe Christmas and a prosperous New Year.

Mick Rankin
Editor.

AADS Executive Committee

President.....Stuart Walton
Vice President F.I.E.....Kevin Cripps
Vice President T/CBert Sievers
TreasurerDoug Riley
Secretary.....Don Holgate
Executive OfficerDon Blanksby
Registered Office AADS Inc:
P.O. Box 6027, Melbourne Vic. 3004.
Phone: (03) 536 3121 Fax: (03) 525 3656
EditorMick Rankin

Reproduction of this production, in part or whole, may not be made without written consent of the Association.

Comments expressed in this publication are those of individuals, and are not necessarily the views of the Association of Australasian Diesel Specialists Inc.

Technical information contained in this journal is obtained from sources deemed reliable within the industry. However, AADS accepts no responsibility for the accuracy of this information.

PRESIDENT'S REPORT

All members will recognise that the association has been through a difficult time in recent months, the enormous void left following the passing of our dear friend Lance has been very hard to come to terms with.

It is also very sad to report the death in November of Jack Hallam. Whilst Jack's membership lapsed some years ago he will be remembered by many of our older members. My deepest sympathy goes out to his family.

On the positive side, I am pleased to announce the appointment of Don Blanksby who will take over the management of our association. Don will be known to many of

you having been very active at the start of our certification and training programmes. Don's contact number for his Melbourne office together with (hopefully) a photo of him and his most able assistant Ann will appear later in this edition.

Convention planning for March 1995 is now well in hand and judging by the list of guest speakers, Melbourne 1995 will be one not to be missed. Recognising that we West Australians are leading the economy out of recession, I am sure that the improvements "over East" will mean you are all trading profitably and therefore keen to take the tax advantages of attending this world class event.

At an executive meeting in early November, the committee were presented with the results of the postal ballot taken on the adoption of the new rules. I am delighted to report that better than 95% of votes cast favoured the changes and therefore the new rules have been lodged and are in force.

I thank you for your support in adopting this new style of management, the key benefit is clearly that each state/branch through its Chairperson now has a seat on the Board of Management allowing direct interaction between Members and Board Members.

In the training area, a survey is to be conducted to establish what you require. It is vital that we have this data before any further enhancements of our existing scheme are put in place. When you receive this survey, please complete it honestly so we can allocate resources to the programme with the knowledge that we are doing what you want and not what the Board think you want.

In closing, I would like to thank the Executive Committee and particularly Don Wilkey for their help and support in keeping the association running during the last few months.

S.N. Walton
PRESIDENT AADS INC.

TREASURER'S REPORT

First up I would like to welcome Don Blanksby and his staff to their appointment with the Association. Don will have a lot to do in the next three months, both with familiarising himself with the Associations running and helping organise the 1995

Melbourne convention. We all wish Don and his crew a warm welcome to the job.

We have had approximately 20 members at this stage who have not paid their annual subscriptions and unfortunately they will have to be struck from the register of Association members.

I recently audited the Associations books before they were handed over to Don Blanksby and found them to be in good order.

I did not receive from Branch treasurers a statement of account for each branch at the November executive meeting.

Branch chairmen are to ensure that we have a balanced figure as at 31st January, for presentation to the February executive meeting.

I look forward to seeing you all at the Convention in March, 95 and would like to wish all members families and staff a Merry Christmas and a safe and prosperous New Year.

Doug Riley
NATIONAL TREASURER AADS Inc.

N.Z. BRANCH REPORT

A.A.D.S. N.Z. Branch held their Annual Conference in Auckland during September and was very well attended with some 88 guests on Saturday night.

During the conference 40 exams were sat by members and staff with some excellent results. I would like to thank Tom and Keith for their support in sending the test paper at short notice once again.

Diesel Progress NZ Limited and Diesel & Turbo have obtained the ISO9001 certification, with other diesel shops in New Zealand in the process of obtaining creditation.

DSL Group Ltd have been appointed the C.A.V. Distributors for New Zealand with Repco retaining the Hartridge Sales.

I would like to wish everyone a Merry Christmas and Happy New Year.

Don Holgate, Chairman NZ Branch AADS Inc.

N.S.W. BRANCH REPORT

Reports have been received on Toyota Hilux 2.8 with oil in sumps solidifying. Engines are not running hot, and have low oil consumption. In such cases oil should be changed frequently, don't use multi grade oils. Castrol CRF30 has been reported as a good oil, for this type of problem.

Some shops in Sydney have reports of poor fuel being supplied in NSW and it would appear there may be a mix of kerosene. Advise drivers to watch for CHEAP priced diesel.

Reports of Harmonic Balancers coming loose after timing belts have been replaced. Mitsubishi, Mazda, Toyota are all typical examples where harmonic balancers have come loose. If you are experiencing this problem the balancer must be tightened up to correct torque as per manufacturers data.

DP201 as fitted to Perkins 3 and 4 cylinder engines used by Massey Ferguson. Reports of drive gear shearing key on drive shaft have been reported. As these engines are still under

warranty, these failures must be reported back to Massey Ferguson, at this present time.

Shibuara with complaint will not idle when hot. PFR pump fitted, governor is under wheel case. The governor sleeve is made from Teflon, and is not drilled all the way through. Therefore hydraulic lock occurs, watch for this.

Mercedes coach 1418 with RQV governor, MW pump flange mounted. Complaints of idle when cold 500 RPM when engine gets hot increases to 800 RPM. All usual checks have been done to no avail. Has anyone got any suggestions?

My very best wishes to all at A.A.D.S. members for a happy Christmas and a bright and prosperous New Year.

My special thanks to the N.S.W. members for supporting the N.S.W. meetings and committee members. I trust 1995 will be another year of improvements for us all.

Happy Festive Season
Ken Scott, N.S.W. CHAIRMAN AADS INC.

RANKIN DIESEL INJECTION SERVICE PTY. LTD.

2-6 MELRICH ROAD
BAYSWATER VICTORIA 3153

Victorian Distributors For



MEMBER

**DIESEL
FLEX**

EMERGENCY
FUEL LINES



DIESEL INJECTION
EQUIPMENT

BCD

PLUNGER & DIAPHRAGM
LIFT PUMPS



AGGLOMERATOR TYPE FAS

Lucas CAV
DIESEL

Lucas Bryce
FUEL INJECTION EQUIPMENT

Stanadyne
DIESEL SYSTEMS



FILTER TYPE FS

PHONE: (03) 762 9133
FAX: (03) 762 8575

FOR SPARE PARTS AND
TECHNICAL ASSISTANCE

VICTORIAN/TASMANIAN BRANCH REPORT

The Victorian/Tasmanian branch held a meeting on Friday 11th November at the World Congress Centre. Following an excellent meal and refreshments at the Anchors Brasserie in the Centra Hotel, the meeting commenced at 7.30pm with thirty one members present.

Stuart Walton addressed the meeting with an updated progress report on the training programme, following discussions with the TECC committee, manufacturers and Batman TAFE the previous day. Stuart also urged all Victorian/Tasmanian members to attend and support the Melbourne convention in march 95 at the World Congress Centre.

Our guest speaker, Mr Greg Moore provided members with an excellent and most informative address relative to the agenda subject of upgrading your business and industry image. Mr Moore is the director of training at the new Crown Casino. Some of the highlight points included:

- Raise your level of attitude and that of your staff.
- Develop a strong passion for your business, the industry and your customers.
- Maintain persistence and don't give up.
- Develop a service vision with positive action.
- Maintain and develop internal and external training of both technical and customer communication skills.
- Make your premises customer friendly.
- Listen to your customers and respect your customers.
- Set yourself a total business plan and ensure you follow your plan. Review and upgrade your plan on a regular basis.
- Keep your employees updated and treat them well.
- Make your employees an important part of your business.

The meeting held a very interesting discussion regarding the importance of developing and upgrading of the fuel injection industry image to meet the challenging and changing 90's. Many of the points raised by our guest speaker were most appropriate. Numerous other important points were raised during the debate providing all present with many ideas to upgrade their business image.

- Investigate charges to reflect your services taking into account your technical and

equipment investment.

- Maintain clean and attractive customer friendly premises.
- Provide positive customer communication, selling your work quality and equipment etc.,
- Listen to your customers and show them respect.
- Sell yourself and your business and equipment and ensure your customer understands that work was performed which justifies your charges.
- Maintain suitable training in technical know how business/management skills and customer communication skills.

Due to the acceptance of the new AADS rules the meeting called for nominations for three state executives covering:

State Chairman.....Nomination....Mick Rankin
State Vice Chairman..Nomination..Bruce Cornell
Secretary/Treasurer....Nomination.....Terry Brain

Members have been circulated regarding any additional nominations. If more than one nomination is received prior to 7th December 1994 a postal ballot will be conducted.

We again remind every Victorian/Tasmanian member to come along and support the Melbourne convention in March 1995 and bring your staff. A great programme is planned by your convention organising committee to provide you and your staff with a wealth of knowledge and information.

Seasons Greetings to you and yours and wishing you a most successful 1995.

Terry Brain
Secretary/Treasurer Victorian/Tasmanian
Branch AADS Inc.

SOUTH AUSTRALIAN REPORT

News from the South Australian membership is that everybody seems happy and coping with the economic situation.

The crows have a Victorian coach, the Grand Prix has been and gone, and the patron saint of pawn brokers, Santa Claus is in town.

In accordance with the new rules, the South Australian Branch AGM and end of year get together will take place on December 9th.

We wish you all a Merry Christmas and A Happy 1995.

Tom Beesley

QLD BRANCH REPORT

The meeting was held at Hyatt Coolum which turned out to be one of the best conference venues that we as members had attended. From the outset the grounds (300 acres with most sports ie. golf, tennis, squash, archery, gyms, clay pigeon shooting, surfing and hiking tours for the energetic) were manicured and the catering and staff performance were outstanding. For the true adventurer a day trip to Fraser Island by 4WD could be arranged and for those who have not seen the Island, we guarantee a sight that will stay with you forever. Clearly a venue for an Association Annual Convention.

Once again our State Chairman was not available so the meeting was chaired by Greg Simmons and assisted by Ted Sanders. The attendance comprised of 15 service and 2 marketing members and though the attendance was smaller than anticipated it turned out to be a quality meeting with some very constructive and at times thought provoking input.

At our last meeting it was acknowledged that the Association Branch (and Nationally perhaps) had,

- a) Lost drive and was in desperate need of a higher profile and better public image.
- b) That a more professional approach by the members to the general public was needed.
- c) That much more feedback from the Executive to the State Branches was required if the members were to be more informed.
- d) That a much greater emphasis was to be placed on training and that full co-operation be asked of the equipment manufacturers to assist the Association in this complex and delicate task.

On the aspect of awareness the Branch has approached a number of plastic bag manufactures re printed bags with the Association logo and window. We now have a firm quote from Jonmar Plastics and individual members will be able to order these bags for their own use.

Signage is available using your obsolete fluorescent sign casing for which new panels with the AADS logo can be purchased from Wide Bay Signs at a reasonable cost.

With the advent of the new rules coming into being the Branch feels confident that feedback from the Executive will automatically be more forthcoming and direct.

While the above changes will be brought about to the best of the Branch Executive's ability it will all be meaningless unless YOU the member decide the Association is worth

saving and assist with your own input, be it verbal or written.

A lot of discussion has revolved around the role of support the manufacturers should play in the Association and I believe that each member has the right to expect every manufacturer to supply a product that is uniform in quality, be available on demand, and carry warranty from that manufacturer irrespective of the point of distribution. One would expect the manufacturer, in an effort to protect the good name and quality of their product, to be only too eager to share the knowledge and technical know how required to service their goods. In the fuel injection industry it would be extremely short-sighted by any FIE manufacturer to forget that there are 240 potential customers using their genuine product on a daily basis and at the end of that day whether that repairer be competent or not, he is the OE's sole representative and advocate.

With this in mind, now is a timely reminder that manufacturers have their standards and that if we, in the fuel injection industry expect to service their product competently, then it is only natural to perform such service on up-to-date test equipment with the emphasis that such equipment complies with ISO standards.

On a lighter note, we once again had a very spirited and extremely informative technical forum and in future issues intend to publish (print) our Question & Answer format similar to that of NSW as it has been pointed out to us that a few members actually copy parts of the NSW Technical Forum and put it in a separate binder for quick reference. We must also point out that we don't think NSW are smarter than us yet!

Input and Information were sought from various members who have implemented, or are implementing Q.A. We intend proceeding with Q.A. at a Branch level by using the MTAQ programme, the reasons being:

1. Significant reduction in fees because it is Government funded,
2. User friendly,
3. Enables us to be recognised as a separate trade by the MTA and Queensland Government.

In conclusion the Association is at its crossroads and with the implementation of the new rules and the positive input that could be generated by each Branch, has the potential to make this Association an all-powerful and professional body which would be well known and respected by the general public and our trade associates.

The Branch would also like to welcome

Vonnie Merritt as Secretary/Treasurer and also Craig White as Vice Chairman. Our sincere appreciation is extended to Ted Sanders for the dedication he has extended to the Association the past 12 months.

Greg Simmons, Chairman, Qld. Branch AADS Inc.

PROFILE - TERRY BRAIN



Terry was born on New Years eve in 1938 in the suburb of Camberwell. Terry senior and Dorothy Brain raised Terry and his younger brother Peter in Ashburton.

Terry went to Ashburton Primary School and was enrolled at Caulfield Technical College (now the Caulfield campus for Monash University). Terry started his working career in 1954 with a company called Canada Cycle and Motor Company, who were the Australian distributors for Dodge, Chrysler, Peugeot, N.S.U. Prinz and Studebaker motor vehicles. He was employed in the automotive electrical division and after completing a five year apprenticeship, gained his tradesmans certificate. Later on he became foreman of the department.

In 1965 Terry started up his own automotive electrical business in Ashburton. In 1966 he accepted the position of technical service representative with Lucas Australia, with the intention of gaining additional technical experience for a couple of years and then developed his own business. He continued in this position for five years and covered both technical matters and developed and handled sales to distributors and major accounts.

In 1971 he was promoted to state sales manager Victoria/Tasmania. In 1974 was promoted to state manager Victoria/Tasmania. During this period Terry was responsible for sales revenue and in 1971 achieved \$251,000 with a staff of twenty five people. Following aggressive change in distribution policy sales, revenue increased to \$11 million in 1984, with the development of ten

branch outlets with 116 personnel in his network.

In 1984 Terry was promoted to national sales and distribution manager at Lucas headquarters in Mordialloc and was responsible for national sales and the distribution of all aftermarket products.

After the sale of Lucas Australia to Jaguar Rover Australia (JRA), Terry looked after the Victorian/Tasmanian state operations and later handled all major national accounts for Lucas products group and original equipment accounts. After twenty six years his career with Lucas/JRA came to an end with the winding up of JRA.

In 1991 Terry joined Diesel Systems Australia and is currently the general manager of D.S.A.

Terry met his wife Vicki when they worked together at Canada Cycle and Motor Company. They were married in 1966 and have three children, Natalie, Darren and Marissa. Marissa has just completed her VCE.

As the family was growing up Terry devoted his weekends to scouting activities, tennis and softball. Terry and Vicki enjoy a very close family life and have spent many enjoyable Saturdays over the years watching aussie rules VFL/AFL games. The kids have now converted him into a Hawks supporter.

Terry played football with South Melbourne between 1956 and 1961. Terry's dad was a top line footballer with South Melbourne. He played from 1923 to 1937, a total of 141 games and kicked 197 goals. He won the "Best and Fairest" in 1934 and played in South Melbourne's last premiership in 1933.

Terry and Vicki have been deeply involved in the Glen Waverley softball club and the Waverley softball association. In 1992 Terry successfully coached the under sixteen team and won the grand final. Natalie was assistant coach and Marissa played catcher in the team.

Terry now plays golf at Churchhill Park in Endeavour Hills each weekend or any given opportunity. His handicap is 27 and he has a fairly slim chance of reducing this, considering the amount of time he spends in the trees and neighbouring fairways.

In his time with Lucas, JRA and DSA, Terry has always been a staunch supporter of AADS, believing that the OEM and service member need each other to prosper and to foster the growth of the diesel injection industry in Australia, and shows his commitment to this ideal by his present position of Secretary/Treasurer of the Victorian Branch of AADS.

LETTER TO THE EDITOR

Dear Sir,

The aims and efforts of the AADS are greatly appreciated, especially by myself as coming from the UK. As no comparable organisation exists, I personally think that one of the strengths of the AADS is its independence from the "major manufacturers".

Greg Simmons invited me to contribute to the meeting by writing an open letter containing ideas and issues that are of concern to us as we see them from North Queensland. Some or all of the following issues may have been previously raised, but as I am relatively new to the AADS I do apologise,

QUALITY ASSURANCE

It seems that we must all decide on whether or not to impose this bureaucratic nonsense on ourselves, some members already have or in the process of introducing QA at I believe some considerable cost. What is the general view of the members regarding the need for QA? and how are the talks with M.T.Q.A. with regard to a standard QA programme proceeding. I have been told that the state government will no longer require suppliers of orders to less than a value of \$1000 to be QA accredited, perhaps this is a glimmer of light at the end of the tunnel.

TRAINING

Many pump shops are located at some distance from Melbourne which seems to be the centre of training in our industry and as F.I.E. becomes more complex the need for training increases. Although there is no substitute for conventional hands on training, perhaps a fair substitute of a sort would be the training at members own premises with the aid of videos. This could be very cost effective as it should save travelling and time spent away from the business costs. I understand the "major manufacturers" have some training videos and if the AADS could purchase these a small library could be established for loan to the members.

MECHANICAL REPAIR LIABILITY INSURANCE

It seems that Australia is following the USA and becoming litigation happy. A problem with a repair can lead to enormous claims for damage, with demands being made not only for restitution or the faulty unit, but any actual or supposed damage to the engine, down time, towing charges, loss of profits etc. Is

there a case here for the AADS to formulate a standard warranty policy, clearly stating the limits of the repairers liabilities, legal assistance may have to be sought in preparing such a policy. Has an approach to an insurance company ever been made with a view to negotiating a general insurance policy to suit the members special needs?

TOOLS AND EQUIPMENT POOL

The special tools and equipment required in our trade are very expensive and to equip a workshop with a comprehensive range will over capitalise the business, which is a problem in the industry.

Perhaps the AADS has a role to play here by purchasing some of the more expensive items on behalf of interested subscribing members. I am thinking here for example of some of the test injectors that may be infrequently used, yet are vital when certain pumps require testing. Obviously even the purchase of a few sets of test injectors would be a major expense and enquiries would have to be made amongst the members to see if there is any interest in such a scheme.

TECHNICAL INFORMATION

Not all members are manufacturing agents and yet are firmly established in the industry with a good name and intend to stay. One of their major concerns is the acquisition of technical information, i.e. test plans, parts lists, manuals and service instruction notes etc., all required for an effective repair. This issue is I know highly political and I think the major issue for the AADS to address.

Geoff Poole, Cairns Diesel Service

Dear Sir,

A Ford Trader 509 1994 fitted with VE injector pump. The fuel return fitting usually marked "out" now has an electrical solenoid fitted to it. It extends down into the pump body about 20mm and has a series of holes along its length. With the engine running at max RPM's and without power to the solenoid, then applying power to the engine, it lifts in RPM's and runs smoother.

Ford and Mazda are unable to help on this issue. Fords response was "we don't know what you are talking about". I would be grateful for any help or information.

Merry Christmas and Happy New Year to all.

Peter East, Bellarine Injector Service
(052) 48 5759

Adelaide Fuel Injection Parts P/L

- ★ BOSCH
- ★ CAV
- ★ NIPPONDENSO
- ★ AMBAC
- ★ DIESEL KIKI
- ★ SIMMS
- ★ CIPA
- ★ ALTECNA
- ★ ROOSAMASTER
- ★ BRYCE



MEMBER

7 Opala Street, Regency Park, S.A. 5010
 Fax: (08) 268 6460 Telex: AA186240

PHONE: (08) 243 2688



REPCO DIESEL

Your one stop
shop for



Australia wide
distribution of:



Hartridge	CAV	SIMMS	Caterpillar	BOSCH
BRYCE	ROOSA MASTER	NIPPONDENSO	ZEXEL	
CHAMPION	Cummins	AMBAC	OMAF DIESEL SYSTEMS	
OMC diesel	IPA	GENUINE SPACCO SPARE PARTS	EPD LIFT PUMPS	YANMAR

CALL: (02) 682 5433 OR TOLL FREE (008) 22 4048 FAX: (02) 682 5380



REPCO DIESEL FUEL INJECTION SERVICE
 8 BRIDGE STREET, GRANVILLE, N.S.W.

RULES COMMITTEE REPORT

For the information of all members, I have to report that 96% of the vote cast in the postal ballot held last October were in favour of the adoption of the re-written Rules of the Association, in the format as submitted to all members. On the face of it this appears to have been an excellent result, but there was a down side in that only 104 members made the effort to exercise the democratic right to vote. I wonder what happened to the other 200 odd ballot papers accompanied by a set of Rules that were posted out because, strangely enough, none have been returned unclaimed?? Does anyone know of a cure for that dreaded disease "apathy"?

The need for the Rules having to be re-written have already been explained either in Diesel Torque or in circulars, but briefly it was to validate the re-structuring of the management that was adopted at the A.G.M. held in Sydney last March.

Now that the adopted Rules have been lodged with the Dept. of Consumer Affairs in N.S.W., they are now effective. So if any financial members or branch wishes to submit or propose any amendments then it must be done via a meeting of the local branch for submission to the Association as a whole, either at a A.G.M., or a Special General meeting called for the purpose.

Yours in service
K. Jurgs, Chairman

TECHNICAL REPORT

It was resolved at the November meeting of the TECC that a questionnaire would be sent to all service members in relation to product training. From the information gathered, the board will make a policy decision on the matter of future AADS product training.

All members should approach the answering of the questionnaire in a positive and thoughtful manner as the future for almost half of the service membership will depend on their attitude to having the right training, tooling and test equipment to meet the expectations of aftermarket service on current and future FIE and Turbocharger equipment.

Industry regulation of service members standards involves a program of training,

certification and accreditation. The new rules outline each service members' responsibility and accountability to ensure that the AADS logo identifies an organisation with credibility.

Members who advertise their business as being a Bosch or Nippondenso franchise are required to maintain their service capability by having factory trained personnel, tooling and test equipment. These members are committed to assure they produce high quality service in support of the Bosch and Nippondenso logo. The same commitment is made by franchised Turbocharger workshops.

Without other AADS members giving a similar commitment to training, to having the required tooling and test equipment, no amount of advertising will be of value to the AADS logo or the Association image.

Quality Assurance is really no big deal. It is very much a moral thing and depends much on you as a person, your standards and how you would like to be treated.

Members who talk about Quality Assurance should think about the two words "Quality" and "Assurance".

"Quality" is that intrinsic capability that something has which enables it to perform to an agreed standard. The word "Assurance". Ask yourself, can I "Assure" anyone that my service capability will attain the agreed quality?

Much of the above report is in response to the Queensland and New South Wales branch reports that appeared in the September issue of Diesel Torque.

Members, when the questionnaire comes to you, spend some time thinking about your future goals and your Association.

Tom Beesley, Secretary
AADS, TECC

TRIVIA

1896 - The first pedestrian to be killed by a car was knocked down in England by a car moving at 6.4 KM/H.

"Failure to hit the bullseye is never the fault of the target".

"One good thing about enemies - they tell you more truth about yourself than your friends do".

INFORMATION REVOLUTION

How many members have had equipment come into their workshop with a problem and find no test plan, no parts lists, nothing to match the piece of equipment. Your customer is anxious to get back on the road. You ring the manufacturer or distributor and most times are told, "That piece of equipment should not be in the country". When you ask for help, you are then greeted with one of the following phrases, "I'll fax them to you when I get back to the office", or "I'll get back to you," or "I'll check the availability of that and call you later in the week". Well, in the near future such phrases could be decidedly old fashioned.

Already launched, is a world-wide system, which in computer language uses an on-line system called "Inter-Net". A service information revolution.

It will be possible for service personnel within participating local or overseas organisations to use "the network" to access technical diagrams, specifications or other information

pertinent to a particular problem in a matter of minutes.

Pie in the sky? No, not so.

I attended a computer "Internet" demonstration a week or so ago. Information on a particular topic was required urgently. The lecturer per his computer identified himself, then the topic, pressed a few keys and forty five seconds later the information that was required was on the computer monitor screen.

Where was the home computer? It was at the Adelaide Flinders University. Where was the source of the required information? It was the Smithsonian Institution, Washington, DC, USA. Remember the time taken? Forty five seconds.

As a plug for Telecom, lets hope our OEM's "Join the Revolution". The faster you receive knowledge or information, the more empowered you are. It is the kind of service that gives you the competitive edge.

Tom Beesley

DSA

DIESEL SYSTEMS AUSTRALIA
5/124 KEYS RD, MOORABBIN, VIC, 3139

AUSTRALIAN DISTRIBUTORS FOR



FRANCESCHI



Rück & Köhler

Robot



PLACE YOUR ORDER WITH TERRY, CHRIS, EMMA OR PAOLA
ON 008 331 277 or 553 4222 OR FAX 03 553 4224

AADS CERTIFICATION EXAMINATIONS

Certification exams were held in New Zealand at the end of September. Twenty nine candidates sat for a total of forty one examinations. It was a good effort and the results encouraging. The senior Technician "V" pump module examination results showed the benefit obtained from attendance at a training school conducted some months earlier by Mike Christie. Discussion and with Don Holgate on the examinations and training and feed back from Mike Christie will help achieve good quality training and examinations in the future.

SUCCESSFUL CANDIDATES

Fie Technician

David Aull, Pass
Walter Barnett, Pass
Carey Bridgland, Pass
Raymond Burge, Pass
Bruce Cooke, Pass
Alwyn Harris, Pass
Robert Johnson, Pass
Martin Kemp, Credit Pass
Alan Montgomerie, Pass
Duncan Moxon, Pass
Warren Richardson, Credit Pass
Dudley Spark, Pass
Rod Walford, Credit Pass

Turbocharger Technician

Jack Fong, Pass
Matthew Hubbard, Credit Pass
Andrew McLeod, Pass
Jim Nielson, Pass
Warren Richardson, Pass
Carl Wakelin, Pass

Senior Technician, Diesel Principles Module

Mike Christie, Pass
John Horn, Pass
Ken Matthews, Pass

Senior Technician. "V" Pump Module

Rex Bennett, Pass
Mike Christie, Pass
Don Holgate, Pass
Matthew Hubbard, Pass
Ken Matthews, Pass

Senior Technician. Turbochargers

Peter Williams, Pass

Congratulations to all successful candidates
Tom Beesley

SAFETY NEWS

FLUROELASTOMER

According to a work cover authority report, a major insurance company in the USA has issued a safety warning regarding products made from Fluoroelastomer.

Fluoroelastomers are commonly used in small automotive O-Rings, gaskets, seals and hoses requiring high temperature performance and fluid resistance. Du-pont sells Fluoroelastomers under the "Viton" trademark. Manufacturer 3M sells the product "Fluorel". Du-Pont advises that normally there is no problem with products containing Fluoroelastomer, however, if misused or exposed to temperatures around 316°C (600°F), decomposition may occur with formation of Hydrofluoric Acid, a substance which is extremely corrosive to human tissue. In severe cases body parts that have been in contact with Hydrofluoric Acid are treated only by amputation. "There is no second chance".



Take care if you have to work on any equipment that has been in a fire and any seals or gaskets have degraded to a charred or black sticky mass. Do not inhale vapours from hot components. Let things cool before working on them.

Wear Neoprene or heavy PVC gloves, wash parts and equipment with a 10% limewater solution and discard the gloves after use. If medical treatment is required advise the doctor that a Hydrofluoric burn is suspected.

Tom Beesley

QUOTE FROM PETRONIUS

A ROMAN OF 210 B.C.

"We trained hard - but it seemed that every time we were beginning to form up into teams we would be reorganised.

I was to learn later in life that we tend to meet every new situation by reorganising - and a wonderful method it can be for creating the illusion of progress while creating confusion and demoralisation.

APOLOGY

A day or two after the posting of the September Issue of Diesel Torque, I received a call from the Editor asking for urgent help as he faced a possible trip to the knackery.

I had misread the test plan if you like and used the wrong members' number to the question that referred to a photograph.

Handling the complaint positively I rang the aggrieved member immediately.

I apologise to member 82 and the Editor for any distress caused because of the error.

When we three met in Melbourne recently at a TECC meeting, we were still friends.

The question should have read, "Is this the face of a star, or member 78?"

The answer is the same - "A Star".

"A crisis has at least one advantage; it forces us to think".

Tom Beesley

STANADYNE ON THE MOVE

Bob Bentley Stanadynes' director - product support, was in Melbourne town during November. Accompanied by Arthur Walz, Bob visited a major automotive organisation.

The Stanadyne "DS" Electronic Fuel Pump is fitted to the GM 6.5L Turbocharged V/8 engine.

Have heard per the grapevine that a number of GM engines are to be fitted to Australian made vehicles.

The "DS" Electronic Fuel Pump requires a specially designed wheel-up test rig to be used in conjunction with test benches suitable for testing other Stanadyne "D" series fuel pumps.

Bob will no doubt elaborate on the purpose and implications of his visit during the AADS convention in Melbourne next March.

Tom Beesley

DIPACO fuel injection parts...available across Australasia

Offering:
**Quality
Service
Training
Warranty**



In Australia contact:

RM DIESEL PTY LTD

(02) 890 1000

Fax (02) 890 1855

Free 008 224 431

Parts for:
**Cummins
Caterpillar
Allis-Chalmers
IHC, Navistar
Mack, GM
and Others**



**DIPACO
DIESEL
PARTS**

In New Zealand contact:

**SIMMS DIESEL & TURBO-
CHARGER SERVICES LTD**

(09) 579 1159

Fax (09) 579 4717

NEW APPOINTMENTS

DONALD C. BLANKSBY
AADS Executive Officer



Don's involvement with the AADS commenced during his time as Chief Executive Officer of the Australian Automotive Industry Training Council Limited when he assisted with an Occupational Analysis Survey on Automotive Diesel Specialists. He worked with the AADS to prepare and obtain a grant to assist in the development of the AADS training programmes.

Don currently operates a company involved in Association Management and Training consultancy, thus his interest in assisting in these aspects of the AADS activities.

Don is a councillor and member of the Australian Institute of Training and Development, and a director of the College of Accredited Trainers.

Don's interests include racing his Dragon yacht at the Royal Brighton Yacht Club, gardening and the ongoing renovation of his house.

Don believes that an Associations strength is through the combined efforts of its members. This networking provides an opportunity for the industry to maintain its professionalism and assist in the education and skills enhancement of its members and their staff.

He looks forward to working with the AADS to achieve its objectives.

ANN TERGIN
AADS Secretary



Ann has worked as Administrative Officer/Personal Assistant for Don Blanksby since August 1994. Her previous career was as an Industrial Relations Specialist in the USA (for the Internal Revenue Service and for the Environmental Protection Agency). She moved from San Francisco to Australia in December 1991, and has lived briefly in Sydney and New Zealand as well as Melbourne. Ann is very involved in an international social running group, the Hash House Harriers, and is currently Grand Master of the Lakeside H3 (Melbourne) chapter.

WANTED

Hartridge HF 490

Hartridge HF 491

Hartridge HA 285

Hartridge HA 100

2 x Bosch 615 Test Benches and accessories

1 x Bosch KMM Test Bench and accessories

All or some in good working order.

Please contact Bryan Newton

South Coast Diesel

Ph: 075 325 427 Fax: 075 322 623

Later model Bosch Test Bench to I.S.O. Standard

Contact: Geoff Poole

Cairns Diesel Service

99 Spence Street, Cairns QLD 4810

Ph: (070) 51 2386

RM DIESEL Pty. Ltd. **10 Years** 1984
SUPPORTING THE AUSTRALASIAN DIESEL FUEL INJECTION INDUSTRY

SPECIALISTS TO THE FUEL INJECTION INDUSTRY

AUSTRALIAN DISTRIBUTOR

YANMAR FUEL INJECTION EQUIPMENT
DIPACO DIESEL PARTS
MERLIN INTERNATIONAL
DUAP SWITZERLAND

Also Stocking:

Lucas CAV DIESEL
Stanadyne DIESEL SYSTEMS
AMBAC
ROBERT BOSCH
NIPPON DENSO

ZEXEL
CATERPILLAR
CUMMINS
SPACO
FEED PUMPS
GLOW PLUGS

PROMPT CUSTOMER SERVICE

RM DIESEL PTY LTD
Free Call 008 224 431

Telephone (02) 890 1000
 Facsimile (02) 890 1855 SALES
 (02) 890 1899 PURCHASING
 (02) 890 1799 ADMINISTRATION

3/106 Grose Street, Parramatta NSW - P.O. Box 2288 North Parramatta NSW 2151

SUMMERTIME SPECIALS

D8N3946	Caterpillar 3208 governor cover	\$180.00 net
M3803	Ultrasonic Cleaner 18 litre, 530x251x152 tank	\$4250.00 inc. tax
M3181	Injector test pipe 6x3x600mm. 14x1.5 nuts	\$17.50 inc. tax
M3188	Injector test pipe-insulated 6x2x600mm. 14x1.5 nuts	\$42.75 inc. tax

INDUSTRY NEWS

A new generation distributor type fuel pump with radial pistons is on the drawing board of a leading manufacturer.

Jaguar engineers have chosen superchargers for performance rather than the more common turbocharger in its latest XJ series range of sedans. The superchargers are belt driven from the engine's crankshaft and give instant throttle response, especially at low speed, in contrast to turbo charging, which relies on the flow of exhaust gas to spin the compressor.

Newly appointed chief executive of Lucas Industries Mr George Simpson has said a "no excuses" culture had to be brought into operation at all levels in order to strengthen the Lucas position with customers.

The Lucas commitment to developing its future technologies and products will be sustained by an expenditure of almost \$250 million, about 4.8 per cent of sales.

Lucas now have a CD Rom based video training package to explain the operation of diesel fuel pumps and electronic control units.

Following close on the news of the fitment of the Lucas Epic System to the Mercedes C220, Peugeot (PSA) the largest diesel car manufacturer in Europe, is to fit the Lucas Epic System to its four cylinder three valve per cylinder, 2088c turbocharged engine which will be used on Peugeot and Citroen models.

Tom Beesley

FOR SALE

1 only Hartridge VDM HF580 - Excellent condition

Contact: Gary McDuff
Fuel Injection Technology
23 Bourbong Street, Bundaberg QLD 4670
Ph: (071) 53 2099

WANTED

**PSB4A100G5811A5 Fuel Pump - Suit
Allis/Chalmers Crawler Loader
Model 7G (7000 Series)
Engine No. 7000 AD145
Serial No. 22222 to 27200
Allis/Chalmers Part No. 74354230 Pump
Allis/Chalmers Part No. 74347834 Gear**
Contact: Graeme
Mildura Fuel Injection Service
138 Tenth Street, Mildura Vic 3500
Ph: (050) 23 7788

DISCRETION: Putting two and two together and keeping your mouth shut.

DIPLOMACY: The art of jumping into troubled waters without making a splash.

SUBTLETY: Saying what you think and then getting out of range before it is understood.



NEW RELEASE

O.T.C. Diesel Service and Diagnostic Tools

See them at the
AADS Convention
March 1995

For prior information
Phone (03) 761 0611



SCHWITZER PARTS TO SUIT: AIRESEARCH — HOLSET — K.K.K. — CATERPILLAR — CUMMINS — ROTOMASTER — I.H.I.

DIESEL TURBO KITS TO SUIT:

TRACTORS: FORD 8600, 8700, TW10, 6610 — INTERNATIONAL 3288, 766, 786, 866, 886, 1420, 1440, 1620, 1640 — AXIAL FLOW HEADER, JOHN DEERE 4040 — FIAT 1580

TRUCKS: INTERNATIONAL NUSS — ISUZU, 4BD1, 6BB1, 6BD1, 6BG1 — UD, FD6, PE6, N1750, CK11 — HINO EH700 SUPER DOPPLIN, MITSUBISHI FK215, FM215, FV458, FM415, V8

RV VEHICLES: TOYOTA L, 2L, 3L, H, 2H, HZ AND B SERIES — NISSAN TD, LR, GQ PATROL, TD27 NAVARA — FORD MAVERICK TD42.

CUSTOM MADE KITS TO SUIT OTHER VEHICLES. ANY ENQUIRIES WELCOME. FULL FUEL INJECTION BACK UP AVAILABLE IN OUR WORKSHOP.

SPECIAL DEALS ON SCHWITZER CUMMINS REPLACEMENT TURBOCHARGERS.

TURBO DYNAMICS

Sole Authorised Australian Distributor for Schwitzer Turbochargers

364 Edward Street, Wagga Wagga, NSW 2650

Phone: (069) 25 3722, 25 4348 Urgent Parts

Fax: (069) 25 3314



B & E Diesel Spares

3-32 Jarrah Drive, Braeside, Vic. 3195

Stockists of :

- | | | |
|---------------|---------|-----------|
| * CAV | * BOSCH | * G.M. |
| * NIPPONDENSO | * SIMMS | * CUMMINS |
| * ROOSAMASTER | * ZEXEL | * SPACO |

* LARGE RANGE OF LIFT PUMPS

Distributor for :



MEMBER

☎ (03) 587 5591

008 805 809
(FREE CALL)

FAX: (03) 587 5605

ELECTRONIC DIESEL CONTROL (EDC) FOR DISTRIBUTOR TYPE INJECTION PUMPS

APPLICATION

The development of the automatic Diesel engine is governed primarily by requirements for clean exhaust, improved fuel economy, and the optimisation of driveability. These conditions are placing increasingly stringent demands upon the fuel injection system, namely:

- sensitive controls
- ability to process additional parameters
- tighter tolerances and increased accuracy even over very long periods of service.

These demands are fulfilled by the Electronic Diesel Control (EDC). This system provides for electronic measurement, as well as flexible data processing, and closed control loops with electrical actuators. In comparison to the conventional mechanical governor therefore, EDC implements new and improved control functions.

In the Diesel engine, operating characteristics

and combustion are influenced by:

- Injected fuel quantity
- Start of injection
- Exhaust gas recirculation (EGR)
- Charge air pressure

These controlled variables must be optimally adjusted for every working mode in order to ensure efficient Diesel engine operation. To this end, EDC incorporates automatic control loops for the main parameters.

SYSTEM BLOCKS

The electronic control is divided into three system blocks. (see fig.1):

1. Sensors for registering operating conditions. A wide variety of physical quantities are converted into electrical signals.
2. Electronic control unit (ECU) with microprocessors which processes the information in accordance with specific control maps, and outputs corresponding electrical signals.
3. Actuators which convert the ECU's electrical output signals into mechanical quantities.

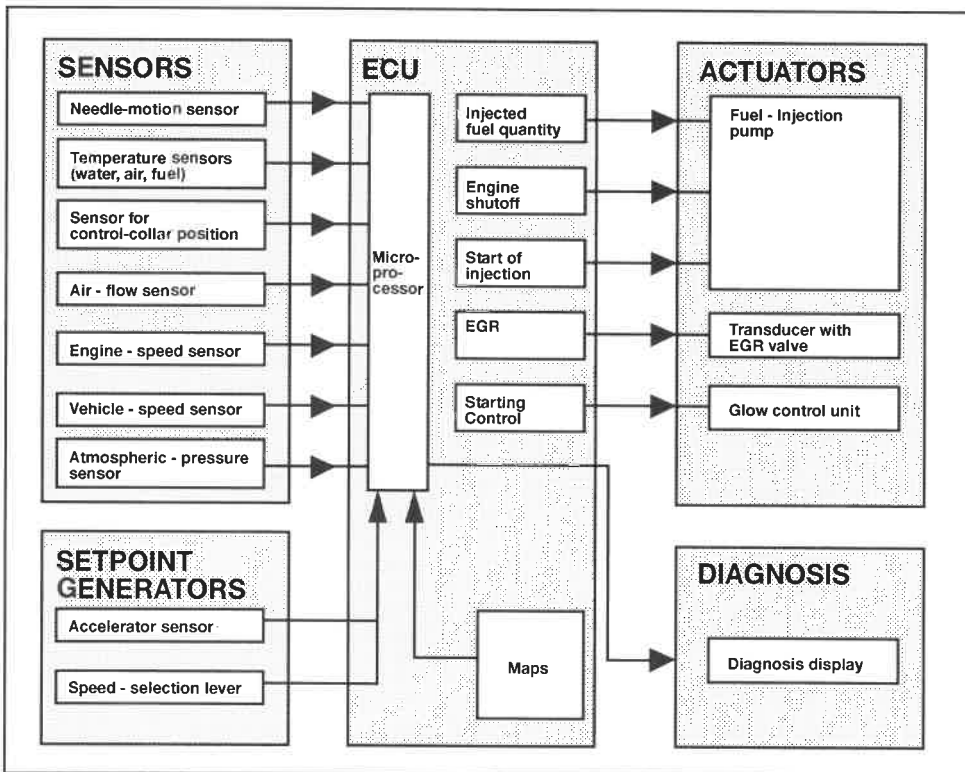

FIG. 1: Electronic Diesel Control (EDC) System blocks

We Salute Our Australian Service Partners.

STANADYNE®

Diesel Systems

Windsor, CT U.S.A.



**FUEL
INJECTION
EQUIPMENT**

MADE IN E.C.



MEMBER

KINGAROY MACHINERY CENTRE P/L
Corner Youngmann and Markwell Streets, Kingaroy
A.C.N. 009 702 149

Australian Distributor for:
C.I.P.A. INTERNATIONAL

Queensland Distributor for:
A M B A C International

Stockists of:
STANADYNE / ROOSAMASTER
OMAP FUEL INJECTION PRODUCTS
ALTECNA / FIAT / IVECO FUEL INJECTION EQUIPMENT
FIRAD FUEL INJECTION PRODUCTS
BCD DIAPHRAGM & PLUNGER LIFT PUMPS

Phone: (071) 62 1266

Fax: (071) 62 4713

COMPONENTS

Sensors

The position of the accelerator and the control collar in the injection pump are registered by the angle sensors. These use either contacting or non-contacting methods. Engine speed and TDC are registered by inductive sensors. Sensors with high measuring accuracy and long term stability are used for pressure and temperature measurements. The start of injection is registered by a sensor that is directly integrated in the nozzle holder and which detects the start of injection by sensing the needle movement (fig. 2&3).

Fig. 2: Sensor signals

- 1 Untreated signal from the needle-movement sensor (NBF).
- 2 Signal derived from the NBF signal.
- 3 Untreated signal from the engine-speed signal.
- 4 Signal derived from untreated engine-speed signal.
- 5 Evaluated start-of-injection signal.

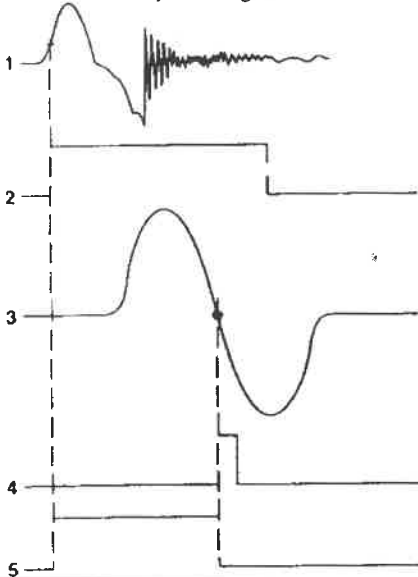

function of such parameters as: load, engine speed, coolant temperature, air quantity etc. Exacting demands are made upon interference immunity. Inputs and outputs are short-circuit proof and protected against pulses from the vehicle electrical system. Protective circuitry and mechanical shielding provide a high level of ECM (Electro-Magnetic Compatibility) against outside interference.

Solenoid actuator for injected fuel quantity control

The solenoid actuator (rotary actuator) engages with the control collar through a shaft (fig.4). Similar to the mechanical governed

Fig. 3: Nozzle-and-holder assembly with needle-movement sensor (NBF)

- 1 Setting pin.
- 2 Sensor winding.
- 3 Pressure pin.
- 4 Cable.
- 5 Plug.

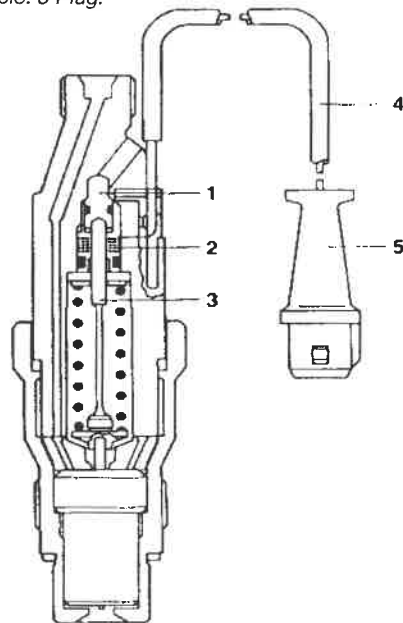

Electronic control unit (ECU)

The ECU employs digital technology. The microprocessors with their input and output interface circuits form the heart of the ECU. The circuitry is completed by the memory units and devices for the conversion of the sensor signals into computer-compatible quantities. The ECU is installed in the passenger compartment to protect it from external influences.

There are a number of different maps stored in the ECU, and these come into effect as a

fuel injection pump, the cut-off ports are opened or closed depending upon the control collar's position. The injected fuel quantity can be infinitely varied between zero and maximum (e.g., for cold starting). Using an angle sensor the rotary actuator's angle of rotation, and thus the position of the control collar, are reported back to the ECU and is used to determine the injected fuel quantity as a function of engine speed. When no voltage is applied to the actuator, its return springs reduce the injected fuel quantity to zero.

Solenoid valve for "start of injection" control.

The pump interior pressure is dependent upon pump speed. Similar to the mechanical timing device, this pressure is applied to the timing - device piston (fig.4). This pressure on the timing - device pressure side is modulated by a clocked solenoid valve.

With the solenoid valve permanently opened (pressure reduction), start of injection is retarded, and with it fully closed (pressure increase), start of injection is advanced. In the intermediate range, the on/off ratio (the ratio of solenoid valve open to solenoid valve closed) can be infinitely varied by the ECU.

programmed into the ECU.

The driver inputs his or her requirements regarding torque or engine speed through the accelerator sensor. Taking into account the stored map data, and the actual input values from the sensors a setpoint is calculated for the setting of the rotary actuator in the pump. This rotary actuator is equipped with a position sensor that ensures that the control collar is correctly set.

Start of injection

The start of injection has a decisive influence upon starting, noise, fuel consumption and exhaust emissions. "Start of injection" maps

Fig. 4: Distributor injection pump for electronic diesel control

1 Control-collar-position sensor. 2 Solenoid actuator for the injected fuel quantity. 3 Electromagnetic shutoff valve. 4 Delivery plunger. 5 Solenoid valve for start-of-injection timing. 6 Control collar.

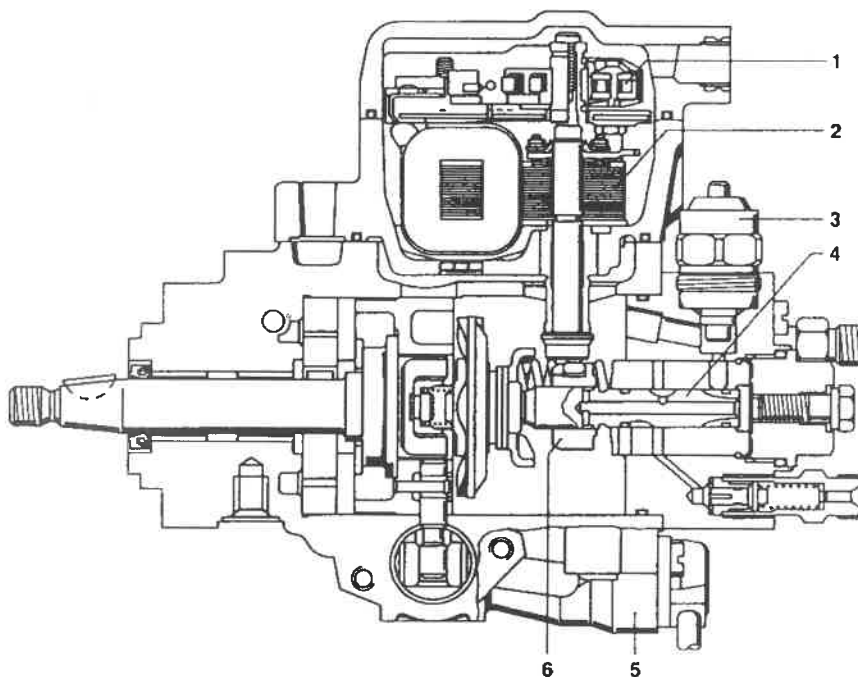

CLOSED CONTROL LOOPS (FIG.5)

Injected fuel quantity

The injected fuel quantity governs starting, idling, power output and driveability characteristics, as well as it influences particle emissions. For this reason, the corresponding maps for start quantity, idle, full load, accelerator pedal characteristic, smoke limitation and pump characteristics are

programmed into the ECU take these interdependencies into account. A closed control loop is used to guarantee the high accuracy of the "start of injection" point. A needle motion sensor (NBF) registers the actual start of injection directly at the nozzle and compares it with the programmed start of injection (fig. 2&3). Deviations result in a change to the on/off ratio of the timing device solenoid.

This clocked solenoid valve is used to modulate the positioning pressure at the timing device piston, and this results in the dynamic behaviour being comparable to that with the mechanical start of injection timing.

Whilst during engine overrun (no fuel injected) and engine starting there are either no start of delivery signals available, or they are inadequate, the controller is switched off and an open loop control mode is selected. The on/off ratio for controlling the solenoid valve is then taken from a control map in the ECU.

electropneumatic transducer. This then adjusts the EGR valve to the correct EGR rate.

Cruise control

An evaluated vehicle speed signal is compared with the setpoint programmed by the driver at the cruise control panel. The injected fuel quantity is then adjusted to maintain the speed selected by the driver.

Supplementary functions

The electronic Diesel control (EDC) provides for supplementary functions which

Fig. 5: Closed control loop of the electronic Diesel control (EDC)

Q - Air flow quantity, *n act* - Engine speed (actual), *P A* - Atmospheric pressure, *S set* - Control collar signal (setpoint),
S act - Control collar position (actual), *Sv set* - Timing device signal (setpoint), *t k* - Fuel temperature,
t L - Intake-air temperature, *t M* - Engine temperature, *ti act* - Start of injection (actual)

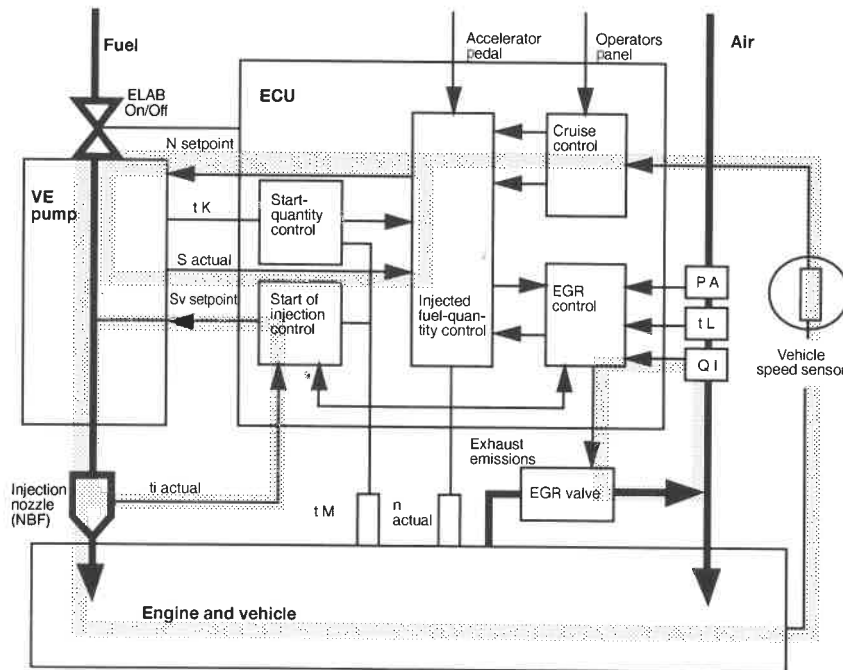

Exhaust gas recirculation (EGR)

EGR is applied to reduce the engines toxic emission. A defined portion of the exhaust gas is tapped off and mixed with the fresh intake air. The engines intake air quantity (which is proportional to the EGR rate) is measured by an airflow sensor and compared in the ECU with the programmed valve for the EGR map, whereby additional engine and injection data for every operating point are taken into account.

In case of deviation, the ECU modifies the triggering signal applied to an

considerably improve the vehicles driveability compared to the mechanically governed injection pump.

Active anti-buck damping

with the anti-buck damping (ARD) facility, the vehicles unpleasant longitudinal oscillations can be avoided.

Idle speed control

The idle speed control avoids engine "shake" at idle by metering the appropriate amount of fuel to each individual cylinder.

SAFETY MEASURES

Self monitoring

The safety concept comprises the ECU's monitoring of sensors, actuators and microprocessors, as well as of the limp-home and emergency functions provided in case a component fails. If malfunctions occur on important components, the diagnostic system not only warns the driver by means of a lamp in the instrument panel but also provides a facility for detailed trouble-shooting in the workshop.

"Limp-home" and emergency functions

There are a large number of sophisticated "limp-home" and emergency functions integrated in the system. For instance if the engine speed sensor fails, a substitute engine speed signal is generated using the interval between the start of injection signals from the needle motion sensor (NFB). And if the injected fuel quantity actuator fails, a separate electrical shut-off device (ELAB) switches off the engine. The warning lamp only lights up if important sensors fail. The table below shows the ECU's reaction should certain faults occur.

Diagnostic output

A diagnostic output can be made by means of diagnostic equipment, which can be used on all Bosch electronic automotive systems. By applying a special test sequence, it is possible to systematically check all the sensors and their connectors, as well as the correct functioning of the ECU.

could not be performed mechanically (e.g. temperature correction of the injected fuel quantity characteristic, load dependant idle control).

- High degree of accuracy throughout complete service life due to closed loop control loops which reduce the effects of tolerances.
- Improved driveability: Map storage enables ideal control characteristics and control parameters to be established independent of hydraulic effects. These are then precisely adjusted during the optimisation of the complete engine/vehicle system. Bucking and idle shake no longer occur.
- Interlinking with other electronic systems in the vehicle leads the way towards making the vehicle safer, more comfortable and more economical, as well as increasing its level of environmental compatibility (e.g. glow systems or electronic transmission shift control).
- The fact that mechanical add-on units no longer need to be accommodated leads to marked reductions in the amount of space required for the fuel injection pump.

ENGINE SHUTOFF

The principle of auto-ignition that applies to the Diesel engine means that the engine can only be switched off by interrupting its supply of fuel.

When equipped with Electronic Diesel Control (EDC), the engine is switched off by the injected fuel quantity actuator (input from

Failure:	Monitoring of:	Reaction:	Warning Lamp:	Diagnostic output:
Correction sensors	Signal range	Reduce injected fuel quantity		●
System sensors	Signal range	"Limp-home" or emergency function (graded)	●	●
Computer	Program runtime (self-test)	"Limp-home" or emergency function	●	●
Injected fuel quantity actuator	Permanent control deviation	Engine switchoff	●	●

ADVANTAGES

- Flexible adaptation enables optimisation of engine behaviour and emission control.
- Clear-cut delineation of individual functions: The curve of full load injected fuel quantity is independent of governor characteristics and hydraulic configuration.
- Processing of parameters which previously

the ECU: injected fuel quantity = zero). The separate electrical engine shutoff device serves as a standby shutoff in case the actuator should fail.

Editors note

Many thanks to Norbert Schueller for this most informative article.

CARPAR'S

A DIVISION OF ATKINS CARLYLE LTD
ACN 008 666 064

FOR YOUR DIESEL PARTS

ALL

INSTANT
ACCESS TO
NATIONAL
STOCK

STANADYNE®
Diesel Systems

OVERNIGHT
EXPRESS
DELIVERY
ON HARD
PARTS

ZEXEL BOSCH

Lucas

CAV

NIPPONDENSO

Bryce

Turbolader

Hartridge

AMBAC

GENUINE
PARTS

AUTHORISED
DISTRIBUTORS

- FUEL INJECTION PUMPS
- GOVENORS ● ELECTRIC GOVENORS
- INJECTORS ● TURBO CHARGERS

THE TOTAL DIESEL RANGE

NATIONAL SALES - SERVICE - SUPPORT



WESTERN AUSTRALIA
52 BELMONT AVENUE
BELMONT 6104
PHONE: (09) 270 2083
FAX: (09) 270 2330



VICTORIA
156 MELROSE DRIVE
TULLAMARINE 3043
PHONE: (03) 277 8866
008 677 887
FAX: (03) 277 8887



NEW SOUTH WALES
108 CARNARVON STREET
AUBURN 2144
PHONE: (02) 748 7288
008 022 204
FAX: (02) 748 4337

MAGASA PACIFIC

in association with **DIESEL RESEARCH.**

The most advanced diesel test benches -

We offer the latest silent drive for all rotary pumps. Unique in it's design. One clip on spanner only is required for H.P. fuel lines.

Also 20 H.P. computerised test bench complete with all attachments for testing any fuel pump.

We offer service and know how - and we do not twist your arm for anything.

We give you a quality product - no strings attached.

Look at this list of some of our satisfied customers who have operated MAGASA benches for between 10 and 20 years without any break downs or cost-

Jack Tricky Diesel	2 x 20 H.P.	16 years
Coastal Diesel Service	F 110	16 years
Wauchope Diesel	F 90	16 years
Queanbeyan Diesel	F 120	16 years
Corio Diesel Service	F 120	15 years
Cornell Diesel Service	F 120	14 years
Moree Diesel	F 120	14 years
Rosier Diesel	F 120	14 years
Sheppard Diesel	F 153	12 years
Horsham Diesel	F 110	12 years
Galloway Diesel	F 120	12 years
C.H.E.S. Engineering	F 120	8 years

New benches are complete. No after sales hidden extra purchases.

Over 100 operating in Australasia.

Come and see us for the 21st Century requirements.

24 month warranty.

Free installation any where in Australasia including Fiji and Noumea.



F-153
12 cyl.
15 H.P.

DIESEL INJECTION (AUSTRALIA) PTY LTD
(DIESEL RESEARCH - AUSTRALIA)
16 Murray Street, MARRICKVILLE, NSW 2204
Phone: 550 1233 Fax: 516 3308

THE BUSINESS WITH 45 YEARS EXPERIENCE, WORLDWIDE
REMANUFACTURERS OF FUEL INJECTION COMPONENTS



ATKINS CARLYLE LTD. (A.C.N. 008 666 064)

(Incorporated in W.A.)

DIESEL FUEL INJECTION PARTS VIA COMPUTER LINKS

Distributors For



- FOR * AMBAC
 * BOSCH
 * LUCAS - BRYCE
 * LUCAS - CAV
 * LUCAS - HARTRIDGE
 * NIPPON DENSO
 * ZEXEL
 * STANADYNE

Distributors For



**Choose Genuine Diesel Parts
and
Diesel Test Equipment**

**NOTE: SKYROAD Overnight
via Interstate transfer available:**

**EACH STATE HAS
IMMEDIATE ACCESS TO
TOTAL NATIONAL STOCKS**

ATKINS CARLYLE LTD
Belmont WA
HERBIE FOENANDER
PHONE (09) 270 2083
FAX (09) 270 2330

KEEP BROS & WOOD
Melbourne Vic
JOHN TOWNSEND
DON SIMS
PHONE (03) 277 8866
TOLL FREE 008 677 887
FAX (03) 277 8887

BENNETT & WOOD
DIESEL DIVISION
Auburn NSW
KEN DODDS
WALLY SMITH
PHONE (02) 748 7288
TOLL FREE 008 022 204
FAX (02) 748 4337

KEEPS ELPHINSTONES
Archerfield QLD
BRUCE WALLIS
TERRY SIMS
PHONE (07) 277 8877
HOT LINE (07) 274 2896
FAX (07) 274 2456

TURBOCHARGERS

- ★ SALES & SERVICE TO ALL MAKES
- ★ EXCHANGE UNITS AVAILABLE
- ★ SAME DAY OVERHAUL SERVICE

AUTHORISED DISTRIBUTOR FOR



BRISBANE H/O (07) 275 1499

32 Raynham St Salisbury Q
4107 Fax (07) 875 1912

ADELAIDE (08) 45 1000

9 Opala St Regency Park SA
5010 Fax (08) 347 0866

MELBOURNE (03) 338 7422

50 King St Airport West Vic
3042 Fax (03) 330 3904

DANDENONG (03) 792 2058

3/207-209 Hammond Rd Dandenong
Vic 3175 Fax (03) 706 8869

SYDNEY (02) 756 3511

12 Blackfriar Pice Wetherill Park
NSW Fax (02) 756 3308

TOWNSVILLE (077) 256 626

26 Hugh Ryan Dve Garbutt Q
4814 Fax (077) 256 615



TURBOCHARGER SERVICES Pty. Ltd.



Turbocharger Sales

QUALITY ENGINEERED
TURBOCHARGER PRODUCTS

Incorporated in Western Australia

PTY. LTD.

SOLE DISTRIBUTORS IN W.A. & N.T. FOR

Napier

Mitsubishi

Holset

K.K.K.

GARRETT

W.A.

Ph: (09) 444 9155

Fax: (09) 444 5847

78 HOWE STREET

OSBORNE PARK W.A.

TURBO CARE SERVICES

Ph: (09) 478 1677

Fax: (09) 479 4209

10 HYNE ROAD

GUILDFORD W.A.

N.T.

Ph: (089) 41 1533

Fax: (089) 81 3061

UNIT 12, FRANCIS BAY

DARWIN N.T.

FULL VSR BALANCING TEST CELL AVAILABLE

SPECIALISED SERVICE INCLUDE, BORING BEARING HOUSING,
RE BLADING WHEELS, REPAIRING BACKPLATES
AND BALANCING

WE ALSO OFFER A COMPREHENSIVE REMANUFACTURING FACILITY FOR ALL
OTHER MAKES INCLUDING SCHWITZER, IHI, NAPIER, BBC & EMD

ALL DIESEL UNITS CARRY 12 MONTHS WARRANTY

A NEW MEASURE OF SUCCESS

Bosch KMM/EPS Combination

ALSO AVAILABLE

- ▶ **EPS 100 Nozzle Tester**
Conforms to design standard ISO 8984. Accurate adjustment of P, S & T nozzles.
- ▶ **RTT 100 Smoke Tester**
Analyses exhaust gas emission for vehicle performance.

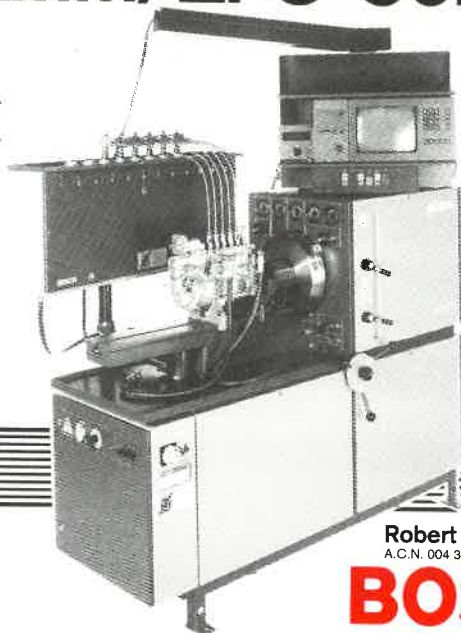

Bosch have combined the proven EPS 711 Diesel Pump Test Bench with the KMM computerised measuring system to allow you to accurately test most of the diesel pumps you repair before they leave your workshop.

- ▶ Melbourne (03) 541 5555
- ▶ Brisbane (07) 891 1855
- ▶ Perth (09) 479 1166
- ▶ Sydney (02) 980 7422
- ▶ Adelaide (08) 344 6888

Robert Bosch (Australia) Pty. Ltd.
A.C.N. 004 315 628

BOSCH



EXCELLENCE · ALWAYS