



Contact Factory for Special Design Requirements



## Electric Hydraulic Scissor Lift Tables

Full featured electric hydraulic scissor lift tables are used by all types of manufacturing and warehouse facilities. Safety features include: electric toe guard to protect pinch points during lowering of the table, brass velocity fuse to maintain platform height regardless of hydraulic pressure, 24V AC push-button hand control, maintenance prop, and upper travel limit switch to stop table at maximum height, reducing motor wear. 2HP, 460V, 3 phase, 60 Hz totally enclosed motor standard, other voltages available. 3000 psi hydraulic component rating.

QUICKSHIP (460V 3 PHASE ONLY)							
MODEL NUMBER	PLATFORM SIZE (W x L)	LOWERED HEIGHT	RAISED HEIGHT	CAPACITY (POUNDS)	VOLTAGE PHASE	NET WT. (POUNDS)	LIST PRICE EACH
EHLT-2448-3-43	24" x 48"	7"	43"	3,000	460/3	700	\$2,430.00
EHLT-3060-3-43	30" x 60"	7"	43"	3,000	460/3	725	2,430.00
EHLT-4048-3-43	40" x 48"	7"	43"	3,000	460/3	800	2,430.00
EHLT-4848-3-43	48" x 48"	7"	43"	3,000	460/3	825	2,430.00
EHLT-4872-3-43	48" x 72"	7"	43"	3,000	460/3	975	2,705.00
EHLT-2448-4-43	24" x 48"	7"	43"	4,000	460/3	775	\$3,080.00
EHLT-3060-4-43	30" x 60"	7"	43"	4,000	460/3	800	3,080.00
EHLT-4048-4-43	40" x 48"	7"	43"	4,000	460/3	850	3,080.00
EHLT-4848-4-43	48" x 48"	7"	43"	4,000	460/3	910	3,080.00
EHLT-4872-4-43	48" x 72"	7"	43"	4,000	460/3	1005	3,080.00

OTHER MOTOR VOLTAGE & PHASE ADD \$160.00 LIST & ONE ADDITIONAL WEEK TO LEAD TIME, model EHLT-VCC DC-20/FC-70

### Model Number Format

EHLT - (width)(length) - capacity - raised height

#### STANDARD FEATURES

- Patented Pinch Point Perimeter Guards for OSHA Compliance
- Fused 24 Volt Push Button Control on 8 ft. Cord
- Adjustable Upper Travel 24V Limit Switch
- Internal Brass Velocity Fuse
- (2HP) 56 Frame Electric Motor
- Pressure Plated Pump & Manifold System
- Robust Heavy Capacity Tables
- Displacement Style Hydraulic Cylinder
- State-of-the-Art Lifetime Lubricated Bearings
- Integral Maintenance Prop



LINE-X® spray on Polyurea/Polyurethane coating available on most Scissor Tables. Contact factory for additional information.

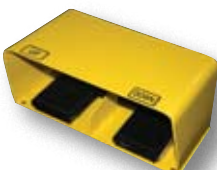

- Optional Foot Control model EHLT-FC, \$88.00 List

VERTICAL TRAVEL	PLATFORM WIDTH	PLATFORM LENGTH	CAPACITY (POUNDS)	RAISED HEIGHT	LOWERED HEIGHT	TRAVEL (^) TIME (SEC)	NET WT. (POUNDS)	LIST PRICE EACH
36"	24" - 48"	48" - 72"	1,000	43"	7"	7	945	\$2,423.00
36"	24" - 48"	48" - 72"	2,000	43"	7"	11	966	2,584.00
36"	24" - 48"	48" - 72"	3,000	43"	7"	16	987	2,961.00
36"	24" - 48"	48" - 72"	4,000	43"	7"	22	1008	\$3,269.00
36"	36" - 48"	48" - 72"	5,000	44"	8"	32	1029	3,477.00
36"	36" - 48"	48" - 72"	6,000	44"	8"	32	1050	3,891.00
36"	36" - 48"	48" - 72"	*8,000	44"	8"	15	1281	\$5,956.00
33"	40" - 60"	48" - 72"	*10,000	43"	10"	15	1438	6,624.00
33"	40" - 60"	48" - 72"	*12,000	43"	10"	15	1596	7,127.00
48"	24" - 48"	64" - 90"	1,000	55"	7"	11	1155	\$3,397.00
48"	24" - 48"	64" - 90"	2,000	55"	7"	16	1176	3,426.00
48"	24" - 48"	64" - 90"	3,000	55"	7"	22	1197	3,678.00
48"	36" - 48"	64" - 96"	4,000	56"	8"	32	1218	\$3,818.00
48"	36" - 48"	64" - 96"	5,000	56"	8"	32	1239	3,941.00
48"	36" - 48"	64" - 96"	6,000	56"	8"	48	1260	4,143.00
48"	36" - 48"	64" - 96"	*8,000	56"	8"	15	1501	\$7,394.00
45"	40" - 60"	64" - 96"	*10,000	55"	10"	15	1659	7,798.00
45"	40" - 60"	64" - 96"	*12,000	55"	10"	20	1816	8,318.00
60"	24" - 48"	84" - 108"	1,000	67"	7"	16	1785	\$4,579.00
60"	24" - 48"	84" - 108"	2,000	67"	7"	14	1806	4,713.00
60"	24" - 48"	84" - 108"	3,000	67"	7"	16	1827	4,961.00
60"	48" - 72"	96" - 120"	*4,000	68"	8"	26	1848	\$5,720.00
60"	48" - 72"	96" - 120"	*5,000	68"	8"	26	1869	6,611.00
60"	48" - 72"	96" - 120"	*6,000	70"	10"	30	1890	7,109.00
60"	62" - 72"	96" - 120"	*8,000	70"	10"	30	2131	\$8,370.00
60"	62" - 72"	96" - 120"	*10,000	72"	12"	30	2289	9,160.00
60"	62" - 72"	96" - 120"	*12,000	72"	12"	30	2446	9,582.00
72"	24" - 48"	102" - 120"	1,000	79"	7"	12	2047	\$5,470.00
72"	24" - 48"	102" - 120"	2,000	79"	7"	16	2068	5,867.00
71½"	48" - 72"	120" - 144"	*3,000	82"	10½"	16	2089	6,426.00
71½"	48" - 72"	120" - 144"	*4,000	82"	10½"	26	2110	\$6,478.00
71½"	48" - 72"	120" - 144"	*5,000	82"	10½"	26	2131	7,567.00
71½"	48" - 72"	120" - 144"	*6,000	82"	12"	30	2152	8,308.00
71½"	62" - 72"	120" - 144"	*8,000	82"	12"	30	2415	\$9,287.00

(^) TRAVEL TIME BASED ON 460V THREE-PHASE MOTOR  
 \*DENOTES 6.5 HP 208-230/460V 3 PHASE (EXTERNALLY MOUNTED)

DC-20/FC-70

## Options for Electric Hydraulic Scissor Lift Tables

### Mechanical Options

- REMOVABLE 42" HIGH HANDRAIL INCLUDING 21" MIDRAIL & NON-REMOVABLE TOE-BOARD ..... \$24.00 LIN-FT./\$350.00 MIN.
- NON-REMOVABLE 42" HIGH HANDRAILS INCLUDING 21" MIDRAIL AND TOE-BOARD .....\$19.00 LIN-FT./\$300.00 MIN.
- 42" HIGH SELF LOCKING GATE UP TO 6 FEET WIDE ..... \$157.00 EACH
- LINK CHAIN CLOSURE GATE WITH SNAP HOOK ENDS FOR MAXIMUM 6 FEET OPENING ..... \$82.00 EACH
- 4-WAY ANTI-SKID STEEL TREADPLATE DECK/PLATFORM ..... \$210.00 EACH
- SEMI-PORTABILITY OPTION (INCLUDES TWO RIGID WHEELS WITH A TWO WHEEL DOLLY JACK) ..... \$325.00 EACH
- FULL-PORTABILITY OPTION FOR 1,000 TO 3,000 LBS. CAPACITY UNITS UP TO 90" LONG. (INCLUDES TWO RIGID & TWO SWIVEL CASTERS) WITH A NON-REMOVABLE PUSH HANDLE, REINFORCED FRAME AND FOOT OPERATED FLOOR LOCK) ..... \$732.00 EACH
- NFPA-701 FIRE RETARDANT ACCORDION SKIRTING - CUSTOMER INSTALLED (INCLUDES HARDWARE) ..... \$10.00/SQUARE FOOT
- NFPA-701 FIRE RETARDANT ACCORDION SKIRTING - FACTORY INSTALLED ..... \$14.00/SQUARE FOOT  
(PLEASE NOTE: SKIRTING DOES NOT ALLOW FOR ELECTRIC TOEGUARDS)
- 12" LENGTH SPLIT HINGED BRIDGE WITH RUNOFF GUARDS AND LIFTING CHAINS (72" WIDE)  
STEEL..... \$325.00 EACH  
ALUMINUM..... \$630.00 EACH
- 18" LENGTH SPLIT HINGED BRIDGE WITH RUNOFF GUARDS AND LIFTING CHAINS (72" WIDE)  
STEEL..... \$360.00 EACH  
ALUMINUM..... \$710.00 EACH
- CAROUSEL (CA-SERIES) MOUNTING TO DECK (PRICING DOES NOT INCLUDE CAROUSEL) ..... \$95.00 EACH
- POWERED CAROUSEL ELECTRIC HYDRAULIC DRIVEN, FIXED-SPEED, HAND CONTROL, MIN. DECK SIZE 54" x 54",  
MAXIMUM CAPACITY 4,000 LBS. (ADD 3-1/2" TO LOWERED HEIGHT (WEIGHT 210 LBS.) ..... \$2,985.00 EACH
- AIR CASTER BEARINGS, MANUAL ROTATION CAROUSEL (ADD 3" LOWERED HEIGHT) ..... \$3,367.00 EACH

### Control Options *(available for most powered products)*

- ADDITIONAL 24V PENDANT HAND CONTROL ON 8 FOOT COIL CORD  
2 PUSH-BUTTON CONTROL ..... \$87.00 EACH  
4 PUSH-BUTTON CONTROL ..... \$158.00 EACH
- 24V NEMA 4 WALL MOUNT CONTROL STATION  
2 PUSH-BUTTON CONTROL ..... \$112.00 EACH  
4 PUSH-BUTTON CONTROL ..... \$180.00 EACH
- ADDITIONAL 24V FOOT CONTROL WITH SAFETY GUARD ON 8 FOOT CORD  
2 PEDAL CONTROL FOR LIFT-HOLD-LOWER CIRCUITS ..... \$148.00 EACH  
4 PEDAL CONTROL FOR LIFT-AND-TILT CIRCUITS ..... \$289.00 EACH
- WIRELESS REMOTE CONTROL  
2-BUTTON CONTROL FOR LIFT-HOLD-LOWER CIRCUITS ..... \$660.00 EACH  
4-BUTTON CONTROL FOR LIFT AND TILT CIRCUITS ..... \$660.00 EACH

### Motor/Power Options *(available for most powered products)*

- 3 HP / 1-PHASE / 115/208-230V MOTOR @ 1½ GPM EXTERNAL - UPGRADE FROM 2 HP (35 AMP DRAW AT 115V) ..... \$1,169.00 EACH
- 6.5 HP / 3-PHASE / 208/230-460V MOTOR @ 4 GPM (INCLUDES 15 GALLON TANK) ..... \$1,103.00 EACH
- NEMA-4 UPGRADE FOR WASH DOWN APPLICATIONS (INCLUDES SPECIAL MOTOR AND ENCLOSURE) ..... \$342.00 EACH
- ROTARY AIR/OIL POWER UNIT (WARRANTY VOID IF USED W/OUT FILTER - REGULATOR - LUBRICATOR (FRL)) (Call factory for decibel rating)  
(AIR REQUIREMENTS 70 CFM @ 70 PSI)  
2-BUTTON CONTROL FOR LIFT-HOLD-LOWER CIRCUIT (INCLUDES TOEGUARDS IF STANDARD) ..... \$634.00 EACH  
4-BUTTON CONTROL FOR LIFT-AND-TILT CIRCUITS ..... \$1,310.00 EACH  
2 PEDAL CONTROL WITH SAFETY GUARDS ..... \$810.00 EACH  
4 PEDAL CONTROL WITH SAFETY GUARDS ..... \$1,640.00 EACH  
1/2" NPT FILTER-REGULATOR-LUBRICATOR (FRL) - VOID WARRANTY IF USED WITHOUT ..... \$320.00 EACH
- RECIPROCATING AIR/OIL POWER UNIT, FOOT TREADLE CONTROL, FOR 1-3K CAPACITY (NO TOEGUARDS) ..... (-)\$150.00 EACH  
1/4" NPT FILTER - REGULATOR - LUBRICATOR (FRL) - VOID WARRANTY IF USED WITHOUT (15CFM @ 100 PSI) ..... \$125.00 EACH
- HAZARDOUS LOCATION POWER UNIT FOR LIFT-HOLD-LOWER CONTROL (REMOVEDLY LOCATED) ..... \$3,820.00 EACH  
(NO TOEGUARDS; **DIVISION 2 LOCATIONS ONLY**)

### Miscellaneous Options *(available for most powered products except where noted)*

- WARNING LIGHT - OPERATES WHEN UP/DOWN BUTTON IS PRESSED ..... \$285.00 EACH
- WARNING BEEPER - OPERATES WHEN UP/DOWN BUTTON IS PRESSED ..... \$195.00 EACH
- HIGH CYCLE BEARING PACKAGE (EHLT SERIES) - AVAILABLE ON TABLES WITH A 36" OR 48" VERTICAL TRAVEL NOT EXCEEDING A CAPACITY OF 4,000 POUNDS (ADDS 3" TO LOWERED HEIGHT) (EHLT only) ..... \$2,720.00 EACH

CONTACT MANUFACTURER FOR OTHER OPTIONS SUCH AS: 2-SPEED PUMPS, ADDITIONAL LIMIT SWITCHES, APPROACH RAMPS, PAINT OPTIONS, REMOVABLE TOEBOARDS, CONVEYORS, RAILS OR TURNABLES (MANUAL OR POWERED) ATTACHED TO DECK OR SPECIAL DECK SIZES.



## Manual Built-In Carousel for Scissor Tables

Position pallets, boxes, or crates without ever stepping around the table. This sleek flush mounted carousel smoothly rotates 360°. Easy to use operation. Capacity is 4,000 lbs. Carousel adds 1" to scissor table service range. Carousel diameter is 45". Platform size is 48" x 48". Scissor table not included. Option for new table purchase only.

MODEL NUMBER	DESCRIPTION	LIST PRICE EACH
ROTATE	MANUAL BUILT-IN CAROUSEL FOR SCISSOR TABLE	\$850.00

DC-20/FC-70



DVD or VIDEO AVAILABLE

## Accordion Skirting

Accordion Skirts have a functional purpose as well as a safety purpose. Skirts comply with the OSHA pinch point specifications. The functional advantage is minimizing dirt and debris accumulation under the platform. Dirt can contaminate electrical and hydraulic components. Life expectancy of both can be substantially reduced by this contamination. Debris such as raw materials, boards, or pallets can restrict the scissor or table movement. Accordion skirts serve to keep debris from damaging the operating mechanism, hydraulic components, or electrical parts. Safety is enhanced by keeping arms, legs, fingers, and toes out from under the table. Standard electric toe-guards are not included when scissor table is fitted with accordion skirt option.

### TABLE SPECIFICATIONS:

- 1) TABLE WIDTH, W = \_\_\_\_\_"
- 2) TABLE LENGTH, L = \_\_\_\_\_"
- 3) TABLE RAISED HEIGHT, H = \_\_\_\_\_"
- 4) TABLE LOWERED HEIGHT, D = \_\_\_\_\_"

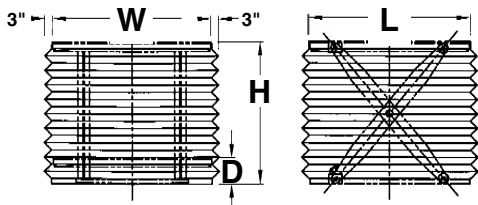

### CALCULATION FORMULA: (3" convolutions)

All Dimensions are in Inches

W = Width of Platform      L = Length of Platform      H = Raised Height

### ACCORDION SKIRTING

**CUSTOMER INSTALLED (including hardware).....\$10.00/SQ. FT.**

### ACCORDION SKIRTING

**FACTORY INSTALLED (includes extra packaging) .....\$14.00/SQ. FT.**

### FORMULA:

$((W + W + L + L) \times H) \div 144 = \text{Square Feet}$

Square Feet x \$10 (customer installed) or \$14 (factory installed) = List Price

### WEIGHT:

0.5 lbs./ft<sup>2</sup>

### REPAIR KIT FOR ACCORDION SKIRTING

**model AC-RK.....\$35.00 LIST**

*Rigid PVC and Roller Curtains Also Available - Contact Factory*

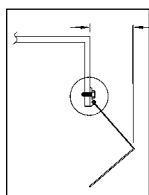

OUTSIDE MOUNTING (STANDARD)

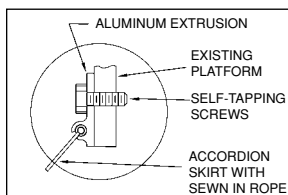

WIRELESS REMOTE CONTROL IS FACTORY INSTALLED

## Wireless Remote Controls

Put the power in your hands with the Wireless Remote Control System, series RC-460. This lightweight, two-button, remote control gives you the freedom to control your scissor table from a range up to 150 feet (range can be adjusted for optimum signal strength and can be reduced if required). Unit is also available in a four-button model for lift and tilt tables. The remote control measures 4" wide x 6" high x 2" thick.

Approved to meet part 15 of the Federal Communications Code. Designed to prevent crosstalk and false triggering from stray radio frequency. Scissor table not included.

MODEL NUMBER	DESCRIPTION	NET WT. (POUNDS)	LIST PRICE EACH
RC-460-2	2-BUTTON CONTROL (LIFT-HOLD-LOWER CIRCUIT)	1	\$759.00
RC-460-4	4-BUTTON CONTROL (LIFT AND TILT CIRCUIT)	1	759.00

RETROFIT AVAILABLE - CONTACT FACTORY

DC-20/FC-70



## Integral Scale for Scissor Tables

- Validate Number of Pieces or Parts
- Know Exactly How Much Weight is on Your Table
- No Holes or Bolting Required
- Installs and Removes in Seconds
- Expedite Your Shipping & Palletizing Process
- Available in Any Size to Fit an Existing Table (Rests on Top of Table)
- Adds approximately 3" to Overall Height
- Scale Functions: Zero Weight and Tare Weight
- Weighing Units: Pounds or Kilograms
- Scale Capacity: 5,000 lbs.
- Mettler Toledo™ Scale
- Scissor Table Not Included

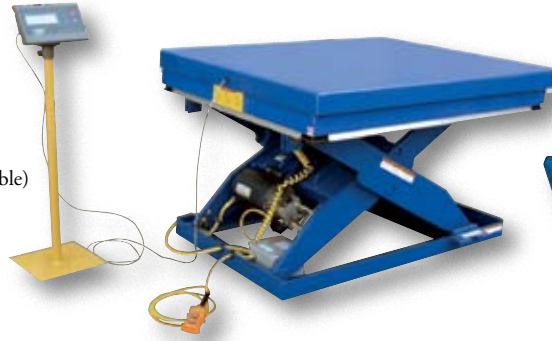

INTEGRAL SCALE  
model SCALE

MODEL NUMBER	DESCRIPTION	WEIGHT (LBS.)	LIST PRICE EACH
SCALE	INTEGRAL SCALE	286	\$1,290.00

DC-20/FC-70

## Auto Sense and Height Index with Integral Scale

- Load and Unload Heavy Loads Easier, Faster and More Efficiently
- Minimum Lifting, Bending and Reaching
- One Touch Auto Height
- Fully Automatic Controller
- Combines precise positioning and weighing capabilities in a single unit
- Fully programmable and automatic:

- Set height function:** Programmable up to four preset heights.
- Increment Function:** When X amount of weight is removed, the table will raise Y inches. 2X amount of weight is removed, the table will raise 2Y inches.
- Decrement Function:** When X amount of weight is added, the table will lower Y inches. 2X amount of weight is added, the table will lower 2Y inches.
- Scale Functions:** Zero weight, Tare (net) weight, and Tare (gross) weight. Raise/Lower Push Buttons on Keypad

- Fully integrated controller with a large display - 2 lines of 20 characters with display function (messages and values)
- A 16-button keypad for programming, editing, and modifying - using all 16 buttons on the panel display
- Scale Capacity: 5,000 lbs.
- Adds approximately 3 inches to the overall lowered height
- Hybrid technology linear sensor is used to control positions at any preset height
- Scissor Table Not Included



AUTO SENSE  
& HEIGHT INDEX  
model SENSE

MODEL NUMBER	DESCRIPTION	LIST PRICE EACH
SENSE	AUTO SENSE & HEIGHT INDEX WITH INTEGRAL SCALE	\$3,557.00

DC-20/FC-70

## Programmable Height

Eliminate unnecessary bending and "land control jogging" by presetting multiple working heights at the touch of a button

- Set height function: Programmable up to 4 preset heights
- Incremental height adjustment for jogging lift at preset increments
- Raise/lower push button on the keypad
- Fully integrated controller with LCD display
- A 15-button keypad for programming, editing, and modifying all 15 buttons on the panel display
- Powered by a 24V DC motor
- Excellent for repeat repositioning applications
- Hybrid technology linear sensor is used to control positions at any preset height
- Scissor Table Not Included



PROGRAMMABLE HEIGHT  
model PROGRAM

MODEL NUMBER	DESCRIPTION	LIST PRICE EACH
PROGRAM	PROGRAMMABLE HEIGHT	\$1,498.00

DC-20/FC-70

## Rotary Air/Hydraulic Scissor Lift Tables

Utilize the efficiency of factory air to power this lift table. Simply connect a 1/2" NPT air line, filter, regulator and lubricator and you now have the most efficient lift table manufactured. Features pneumatic upper travel limit switch, toe guards, internal brass velocity fuse, hinged maintenance prop, two button hand control and state-of-the-art precision pins and bearings.

MODEL NUMBER	PLATFORM SIZE (W x L)	LOWERED HEIGHT	RAISED HEIGHT	CAPACITY (POUNDS)	NET WT. (POUNDS)	LIST PRICE EACH
AHLT-3060-3-43	30" x 60"	7"	43"	3,000	987	\$3,571.00
AHLT-4048-3-43	40" x 48"	7"	43"	3,000	987	3,571.00
AHLT-4848-3-43	48" x 48"	7"	43"	3,000	987	3,571.00
AHLT-4872-3-43	48" x 72"	7"	43"	3,000	1214	3,571.00

CONTACT FACTORY FOR SPECIAL SIZES AND CONFIGURATIONS

DC-20/FC-70





REMOTE POWER UNIT  
measures 24"W x 24"L x 8"H

## Work Station Electric Hydraulic Scissor Tables

Designed to raise products up to an ergonomic working height. The EHLT-WS maximizes safety with minimum space requirements. Ideal for all types of manufacturing and warehouse facilities. External power unit and hand control standard. Electric toe guards standard.

MODEL NUMBER	PLATFORM SIZE (W x L)	LOWERED HEIGHT	RAISED HEIGHT	CAPACITY (POUNDS)	TRAVEL TIME	NET WT. (LBS.)	LIST PRICE EACH
EHLT-WS-2436-1.5-29	24" x 36"	8-5/8"	31"	1,500	13 sec.	700	\$1,669.00
EHLT-WS-2448-1.5-36	24" x 48"	7"	36"	1,500	13 sec.	720	1,727.00
EHLT-WS-3248-1.5-36	32" x 48"	7"	36"	1,500	13 sec.	750	1,756.00
EHLT-WS-4048-1.5-36	40" x 48"	7"	36"	1,500	13 sec.	780	1,806.00

TRAVEL TIME BASED ON 3 PHASE POWER

DC-20/FC-70

## Shorty Scissor Lift Tables

Built with the same quality as all our lift tables, the EHLTS and EHLTSD maximize safety and durability. Designed to raise products up to an ergonomic working height. When tight spaces are what you have, consider a Shorty Scissor Table. Available in both a single and double leg style these tables offer smaller deck sizes customized to your space requirements. Design features include full perimeter pinch point guard and emergency internal brass velocity fuse. External power unit and hand control standard.

Model Number Format: **EHLTS - (width)(length) - capacity - raised height**



SINGLE LEG SET								
VERTICAL TRAVEL	PLATFORM WIDTH	PLATFORM LENGTH	CAPACITY (POUNDS)	RAISED HEIGHT	LOWERED HEIGHT	TRAVEL TIME (SEC)	NET WT. (POUNDS)	LIST PRICE EACH
24"	24" - 48"	36" - 48"	1,000	31"	7"	12	668	\$2,609.00
24"	24" - 48"	36" - 48"	2,000	31"	7"	12	691	2,993.00
24"	24" - 48"	36" - 48"	3,000	31"	7"	12	730	3,697.00
24"	24" - 48"	36" - 48"	4,000	31"	7"	23	721	\$3,995.00
24"	36" - 48"	36" - 48"	5,000	31"	8"	23	744	4,134.00
24"	36" - 48"	36" - 48"	6,000	31"	8"	23	792	4,391.00

TRAVEL TIME BASED ON 3 PHASE POWER

DC-20/FC-70

Model Number Format: **EHLTSD - (width)(length) - capacity - raised height**



DOUBLE LEG SET								
VERTICAL TRAVEL	PLATFORM WIDTH	PLATFORM LENGTH	CAPACITY (POUNDS)	RAISED HEIGHT	LOWERED HEIGHT	TRAVEL TIME (SEC)	NET WT. (POUNDS)	LIST PRICE EACH
42"	34" - 48"	36" - 48"	1,000	51"	10"	16	882	\$4,422.00
42"	34" - 48"	36" - 48"	2,000	51"	10"	23	892	4,931.00
42"	34" - 48"	36" - 48"	3,000	51"	10"	32	903	5,258.00
42"	34" - 48"	36" - 48"	4,000	51"	10"	32	955	\$5,591.00
42"	34" - 48"	36" - 48"	5,000	51"	10"	48	966	5,787.00

TRAVEL TIME BASED ON 3 PHASE POWER

DC-20/FC-70

## Double Scissor Lift Tables

Achieve the extra reach you're looking for with our Double Scissor Lift Tables. These full featured electric hydraulic scissor lift tables are used by all types of manufacturing and warehouse facilities. Safety features include: electric toe guard to protect pinch points during lowering of the table, brass velocity fuse to maintain platform height regardless of hydraulic pressure, 24V AC push-button hand control, maintenance prop, and upper travel limit switch to stop table at maximum height reducing motor wear. 2 HP, 460V, 3-phase, 60 Hz totally enclosed motor standard, other voltages available. 3000 psi hydraulic component rating.

Model Number Format: **EHLTD - (width)(length) - capacity - raised height**

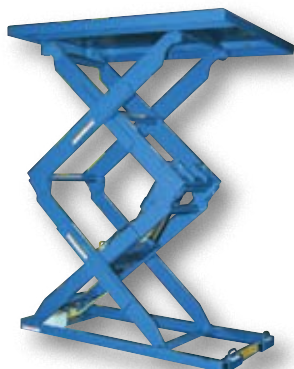

VERTICAL TRAVEL	PLATFORM WIDTH	PLATFORM LENGTH	CAPACITY (POUNDS)	RAISED HEIGHT	LOWERED HEIGHT	TRAVEL TIME (SEC)	NET WT. (POUNDS)	LIST PRICE EACH
60"	34" - 48"	48" - 72"	1,000	70"	10"	11	1470	\$4,422.00
60"	34" - 48"	48" - 72"	2,000	70"	10"	16	1575	4,931.00
60"	34" - 48"	48" - 72"	3,000	70"	10"	22	1680	5,258.00
60"	34" - 48"	48" - 72"	4,000	70"	10"	32	1890	\$5,591.00
60"	34" - 48"	48" - 72"	5,000	70"	10"	34	1942	6,319.00
72"	34" - 48"	64" - 88"	1,000	84"	12"	16	1576	\$5,241.00
72"	34" - 48"	64" - 88"	2,000	84"	12"	32	1680	5,640.00
72"	34" - 48"	64" - 88"	3,000	84"	12"	48	1785	5,792.00
72"	34" - 48"	64" - 88"	4,000	84"	12"	48	1968	\$6,265.00
72"	34" - 48"	64" - 88"	5,000	84"	12"	48	2021	7,570.00

TRAVEL TIME BASED ON 460V THREE-PHASE POWER

DC-20/FC-70

## Portable Scissor Lift Tables

Heavy-duty powered lift tables are designed to transport and elevate your heaviest loads. A heavy-duty 12V DC power unit with deep cycle battery and an on-board battery charger is standard, a battery charge indicator is optional. Features 8" phenolic casters (2 swivel and 2 rigid), floor lock, and patented electric pinch point guards. Push buttons to raise and lower lift, located on power unit and in the pendant-style push-button control, are standard. Key-operated ON/OFF control for better security is built into the power unit. Minimum frame width is 34". Add 25" to platform length for the overall length.

### Model Number Format PST - (width)(length) - capacity - raised height

VERTICAL TRAVEL	PLATFORM WIDTH	PLATFORM LENGTH	CAPACITY (POUNDS)	RAISED HEIGHT	LOWERED HEIGHT	TRAVEL TIME (SEC)	NET WT. (POUNDS)	LIST PRICE EACH
36"	24" - 48"	48" - 72"	1,000	46"	10"	9	1408	\$3,221.00
36"	24" - 48"	48" - 72"	2,000	46"	10"	14	1437	3,284.00
36"	24" - 48"	48" - 72"	3,000	46"	10"	20	1491	4,189.00
48"	24" - 48"	64" - 90"	1,000	58"	10"	14	1496	\$4,321.00
48"	24" - 48"	64" - 90"	2,000	58"	10"	20	1580	4,376.00
48"	24" - 48"	64" - 90"	3,000	58"	10"	28	1780	4,820.00

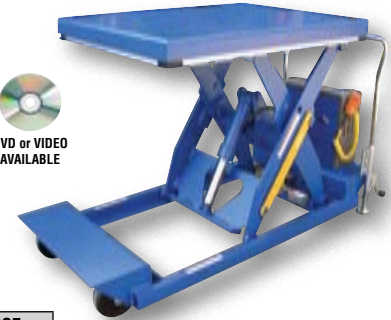

DC-20/FC-70



TILT MASTER STRADDLE WITH PTDS OPTION

### PORTABLE SCISSOR TABLE OPTIONS

MODEL NUMBER	DESCRIPTION	NET WT. (POUNDS)	LIST PRICE EACH
PST-AC	AC MOTOR	--	NO CHARGE
PST-AIR*	FACTORY AIR OVER OIL (W/FOOT TREADLE CONTROL (FRL REQ'D)*)	--	NO CHARGE
PST-FP	MANUAL FOOT PUMP OPTION	--	DEDUCT \$70.00
PST-PTDS	POWER TRACTION DRIVE SYSTEM	156	3,953.00
BC	BENCH TOP STYLE BATTERY CHARGER	8	122.50
BCI	BATTERY CHARGE INDICATOR GAUGE	1	75.00

\*FILTER REGULATOR - LUBRICATOR REQUIRED TO OPERATE (WARRANTY VOID WITHOUT)



PALLET MASTER/PALLET SERVER WITH PTDS OPTION

## Power Traction Drive System

Reduce worker fatigue and injury with the Portable Traction Drive Option. This factory installed option is available on portable equipment including the Portable Scissor Table, Pallet Master/Pallet Server, Tilt Master, and High Rise Lift Truck. An alternative to costly fork trucks, the PTDS includes a combination throttle / direction butterfly style controller, an adjustable yoke and an auto reverse emergency "belly" switch. This state of the art option allows a single operator to safely and ergonomically transport products. Power pack is 42" wide. Maximum speed is 2.5 m.p.h.

MODEL NUMBER	DESCRIPTION	NET WT. (POUNDS)	LIST PRICE EACH
PTDS	POWER TRACTION DRIVE SYSTEM	156	\$4,111.00

DC-20/FC-70

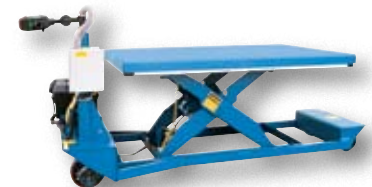

PORTABLE SCISSOR TABLE WITH PTDS OPTION

## Air Bag Scissor Lift Tables

Air Bag Scissor Lift Tables use factory air for clean, dependable, maintenance free operation. Designed to raise products up to an ergonomic working height. Safety features include pressure relief and pinch point guard. Must be used in conjunction with a filter/regulator. We do not recommend the use of a lubricator. Includes hand held control with up and down button mounted on 8 ft. cord. Incoming air must be clean, dry and regulated to 80 psi (min.). Requires 1/2" incoming airline. Standard features are adjustable upper travel limit valve, state-of-the-art lifetime lubricated bearings and maintenance prop. Other sizes available, contact factory.

### Model Number Format ABL - (width)(length) - capacity - raised height

VERTICAL TRAVEL	PLATFORM WIDTH	PLATFORM LENGTH	CAPACITY (POUNDS)	RAISED HEIGHT	LOWERED HEIGHT	TRAVEL TIME (SEC.)	NET WT. (POUNDS)	LIST PRICE EACH
28"	42" - 60"	48" - 72"	2,000	36"	8"	14	897	\$3,829.00
28"	42" - 60"	48" - 72"	4,000	36"	8"	28	942	4,258.00

OPTIONAL FOOT CONTROL, MODEL ABLT-FC, \$195.00 LIST

DC-20/FC-70





## Foot Pump Scissor Lift Tables

Foot pump activated lift tables. Used by all types of manufacturing and warehousing facilities. Features torsion tubes for side to side stability, pressure flow control valve for controlled lowering, and foot pump. Optional power-lift feature available (on-board charger included on DC option). Scissor tables can be made mobile with the optional handle and caster kit. Rugged welded steel construction. Painted blue finish.

48 Hours  
to Ship



SCTAB-400  
SCTAB-800D (double) (not shown)

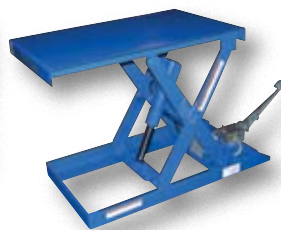

SCTAB-500



SCTAB-1000  
(Shown with  
Caster/Handle Kit)

MODEL NUMBER	PLATFORM SIZE (W x L)	CAPACITY (POUNDS)	RAISED HEIGHT	LOWERED HEIGHT	# OF PUMPS AT HIGH/LOW SPEED	NET WT. (POUNDS)	LIST PRICE EACH
SCTAB-400	17½" x 27½"	400	29"	8¼"	19	164	\$356.00
SCTAB-500	20" x 33"	500	28"	6"	13 / 26	274	803.00
SCTAB-750D	20" x 40"	750	35"	7"	8 / 16	284	1,038.00
SCTAB-800D	20" x 35½"	800	51"	13"	12 / 39	274	776.00
SCTAB-1000	20" x 40"	1,000	32"	8"	8 / 16	270	980.00
SCTAB-2000	42" x 42"	2,000	32"	8"	16 / 32	386	1,366.00

DC-20/FC-70

**LINE-X**  
Custom Finish Available

DVD or VIDEO AVAILABLE

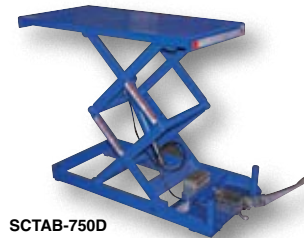

SCTAB-750D



SCTAB-750D  
(shown with DC power option and  
caster handle kit)

### FOOT PUMP SCISSOR TABLE OPTIONS

MODEL NUMBER	DESCRIPTION	NET WT. (POUNDS)	LIST PRICE EACH
SCTAB-DC*	12V DC HAND CONTROL WITH DEEP CYCLE BATTERY	54	\$575.00
SCTAB-AC*	24V AC HAND CONTROL WITH 115V 1 PHASE POWER	36	575.00
SCTAB-AIR*	FACTORY AIR OVER OIL WITH FOOT TREADLE CONTROL	18	407.00
SCTAB-CHK-1*	CASTER & HANDLE KIT (500, 750D & 1000 only)	18	87.00
SCTAB-CHK-2*	CASTER & HANDLE KIT (2000) (FACTORY INSTALLED ONLY) ADD 6½" TO RAISED AND LOWERED HEIGHTS	18	155.00
SCTAB-HDS	HIGH DENSITY PVC SURFACE	4	\$68.00
SCTAB-BC*	BENCH TOP STYLE BATTERY CHARGER	8	122.50
SCTAB-BCI*	BATTERY CHARGE INDICATOR	1	75.00

\*NOT AVAILABLE ON THE SCTAB-400 AND SCTAB-800D



DVD or VIDEO AVAILABLE

## Ground Lift Scissor Tables

Designed for use when fork trucks are not available. Pallets can be loaded onto platform with pallet trucks and raised to an ergonomic working height. Safety features include; entry-side electric toe guard to protect pinch points during lowering of the table, velocity fuse to maintain platform height regardless of hydraulic pressure, foot control, maintenance prop, and upper travel limit switch to stop table at maximum height reducing motor wear. 2HP, 208-230/460V, 3-phase, 60 Hz totally enclosed motor is standard, other voltages available. Remote power unit can be located up to eight feet away from table. 3000 psi hydraulic components rating. Optional accordion skirting available, contact factory.

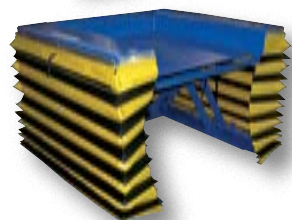

ACCORDION SKIRT AVAILABLE,  
CONTACT FACTORY

MODEL NUMBER	PLATFORM SIZE (W x L)	CAPACITY (POUNDS)	RAISED HEIGHT	LOWERED HEIGHT	OVERALL SIZE (W x L x H)	NET WT. (POUNDS)	LIST PRICE EACH
EHLTG-4450-2-36	44" x 50"	2,000	36"	1/2"	67" x 56" x 8½"	1620	\$3,876.00
EHLTG-4450-4-36	44" x 50"	4,000	36"	1/2"	67" x 56" x 8½"	1690	4,622.00
EHLTG-5250-2-36	52" x 50"	2,000	36"	1/2"	75" x 56" x 8½"	1690	3,959.00
EHLTG-5250-4-36	52" x 50"	4,000	36"	1/2"	75" x 56" x 8½"	1890	4,784.00
EHLTG-4470-2-48	44" x 70"	2,000	48"	1/2"	67" x 78" x 10"	1995	\$4,172.00
EHLTG-4470-4-48	44" x 70"	4,000	48"	1/2"	67" x 78" x 10"	2310	5,132.00
EHLTG-5270-2-48	52" x 70"	2,000	48"	1/2"	75" x 78" x 10"	2205	4,267.00
EHLTG-5270-4-48	52" x 70"	4,000	48"	1/2"	75" x 78" x 10"	2520	5,227.00

### OPTIONS

EHLTG-44-SB	STEEL ROLLOVER BRIDGE FOR 44" WIDE DECKS (8" LONG)	27	\$246.00
EHLTG-52-SB	STEEL ROLLOVER BRIDGE FOR 52" WIDE DECKS (8" LONG)	33	326.00

DC-20/FC-70

## Hydraulic Motorcycle Lift

Manual foot pump activated stationary lift. Ideal for casual and professional riders to work on their motorcycles. Features a front tire cradle to hold wheels up to 6" wide. The hinged ramp measures 27½" wide by 21½" long.



MAINTENANCE DOOR



MODEL NUMBER	OVERALL SIZE (W x L)	BASE FRAME (W x L)	CAPACITY (POUNDS)	SERVICE RANGE	NET WT. (POUNDS)	LIST PRICE EACH
MOTO-LIFT-1100	35" x 108"	26¾" x 65"	1,100	7" to 32"	517	\$1,134.00

DC-25/FC-70

## Low Profile Electric/Hydraulic Scissor Lift Tables

Load and unload skids with a pallet truck without the need for a pit when using the optional approach ramp. Superior engineering features rugged dependability. Safety features include electric perimeter pinch point guard, emergency stop velocity fuse in cylinders, fused 24V AC hand held control and maintenance supports. Remote power unit comes complete with a plastic cover to protect motor from dust and debris. Note motor voltage and phase when ordering.



### Model Number Format EHLTX - (width)(length) - capacity - raised height

VERTICAL TRAVEL	PLATFORM WIDTH	PLATFORM LENGTH	CAPACITY (POUNDS)	RAISED HEIGHT	LOWERED HEIGHT	TRAVEL TIME (SEC)	NET WT. (POUNDS)	LIST PRICE EACH
35¾"	36" - 60"	53" - 60"	1,000	39"	3¼"	14	1470	\$3,411.00
35¾"	36" - 60"	53" - 60"	2,000	39"	3¼"	14	1627	3,624.00
35¾"	36" - 60"	53" - 60"	3,000	39"	4¼"	22	1680	4,158.00
35¾"	36" - 60"	53" - 60"	3,500	39"	4¼"	22	1869	4,371.00

APPROACH RAMP FOR LOW PROFILE SCISSOR TABLES						
MODEL NUMBER	WIDTH	LENGTH	HEIGHT	NET WT. (POUNDS)	PRICE EACH	
ARX-3617-3	36"	17"	3¼"	108	\$215.00	
ARX-3623-3	36"	23"	3¼"	186	292.00	
ARX-3622-4	36"	22"	4¼"	138	231.00	
ARX-3630-4	36"	30"	4¼"	206	308.00	

DC-20/FC-70 (ARX SHIP FC-60)

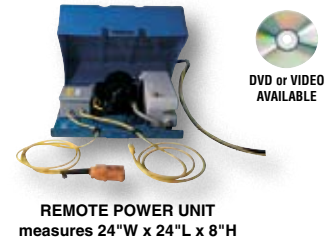

REMOTE POWER UNIT measures 24"W x 24"L x 8"H

## Low Profile "U" Type Electric Lift Tables

The open center on the "U" Type Electric Lift Tables enables a pallet truck to place a load on the platform. Units feature an external power pack equipped with a pressure relief valve that prevents overloading and a flow control valve that controls the lowering speed. Remote power pack comes complete with steel cover to protect the motor from dust and debris. Raise and lower the unit using the UP and DOWN push-buttons on the 24V control box. Safety features include electric toe guards, velocity fuse in cylinders, safety maintenance props and an emergency stop button on the control box.

MODEL NUMBER	PLATFORM SIZE (W x L)	CAPACITY (POUNDS)	LOWERED HEIGHT	RAISED HEIGHT	NET WT. (POUNDS)	LIST PRICE EACH
EHU-2	45" x 56"	2,000	3-3/8"	33-7/8"	630	\$2,680.00
EHU-3	45¾" x 63"	3,000	4-1/8"	33-7/8"	850	2,990.00

DC-20/FC-70



model EHU-2

## Lift & Tilt Scissor Tables

Performs both lifting and tilting operations. 45° tilt standard. Restraining chain and 12" high lip to keep the load in place during tilting. Safety features include: electric toe guard to protect worker from pinch points during lowering of table, velocity fuses to stop travel due to loss of hydraulic pressure, 4 push-button hand pendant control on an 8 foot coil cord, upper limit switch to stop travel at maximum height reducing motor wear, and maintenance prop. End tilt standard, side tilt available. Optional accordion skirting available for both the lifting and tilting portions of the table, contact factory.

MODEL NUMBER	PLATFORM SIZE (W x L)	CAPACITY (POUNDS)	RAISED HEIGHT	LOWERED HEIGHT	OVERALL SIZE (W x L)	NET WT. (POUNDS)	LIST PRICE EACH
EHLTT-3648-1-47	36" x 48"	1,000	47"	11"	36" x 53"	1060	\$3,854.00
EHLTT-4848-1-47	48" x 48"	1,000	47"	11"	48" x 53"	1113	4,079.00
EHLTT-3648-2-47	36" x 48"	2,000	47"	11"	36" x 53"	1181	\$4,278.00
EHLTT-4848-2-47	48" x 48"	2,000	47"	11"	48" x 53"	1296	4,440.00
EHLTT-3648-3-47	36" x 48"	3,000	47"	11"	36" x 53"	1249	\$4,877.00
EHLTT-4848-3-47	48" x 48"	3,000	47"	11"	48" x 53"	1365	5,146.00
EHLTT-3648-4-47	36" x 48"	4,000	47"	11"	36" x 53"	1312	\$5,472.00
EHLTT-4848-4-47	48" x 48"	4,000	47"	11"	48" x 53"	1433	5,848.00

LIFT & TILT SCISSOR TABLE OPTIONS			
MODEL NUMBER	DESCRIPTION	NET WT. (POUNDS)	LIST PRICE EACH
EHLTT-FCH	FOUR PEDAL FOOT CONTROL (LIFT & TILT PRODUCTS)	12	\$289.00
EHLTT-HCA	AIR/OIL POWER W/PNEUMATIC PUSH BUTTON (FRL REQ'D)*	36	1,275.00

\*FILTER - REGULATOR - LUBRICATOR REQUIRED TO OPERATE UNIT



DVD OR VIDEO AVAILABLE



STANDARD END TILT SHOWN

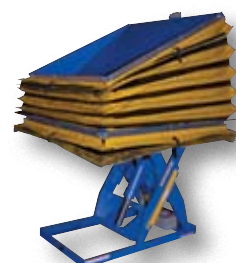

ACCORDION SKIRT AVAILABLE, CONTACT FACTORY

DC-20/FC-70+





DVD or VIDEO AVAILABLE

**LINE-X**  
Custom Finish Available



DVD or VIDEO AVAILABLE

model UNI-4848-4

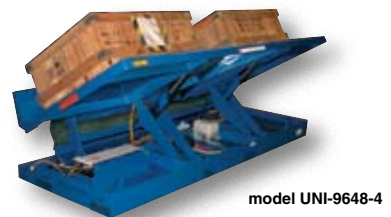

model UNI-9648-4

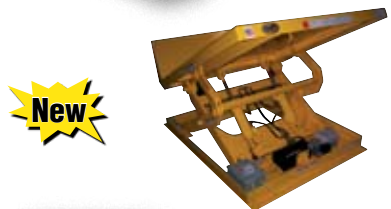
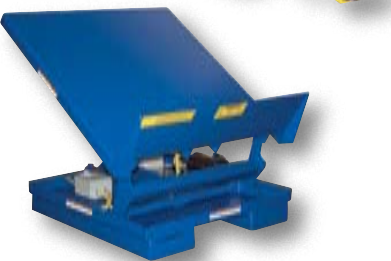

## Zero Lift & Tilt Tables

Designed to lift or tilt products to an ergonomic working position, reducing operator bending. Products may be loaded and unloaded with the use of a standard hand pallet truck. No pit mounting required! Maximum tilt angle is 45°. Lift and tilt controlled separately. Remote power unit with hand-held control standard.

MODEL NUMBER	PLATFORM SIZE (W x L)	CAPACITY (POUNDS)	RAISED HEIGHT	OVERALL SIZE (W x L x H)	NET WT. (POUNDS)	LIST PRICE EACH
ZLTT-4452-2-36	44" x 52"	2,000	36"	69" x 59" x 24"	2121	\$4,348.00
ZLTT-4452-4-36	44" x 52"	4,000	36"	69" x 59" x 24"	2173	5,265.00
ZLTT-5252-2-36	52" x 52"	2,000	36"	77" x 59" x 24"	2205	4,446.00
ZLTT-5252-4-36	52" x 52"	4,000	36"	77" x 59" x 24"	2257	5,364.00
ZLTT-4472-2-48	44" x 72"	2,000	48"	69" x 79" x 24"	2950	4,701.00
ZLTT-4472-4-48	44" x 72"	4,000	48"	69" x 79" x 24"	3013	5,880.00
ZLTT-5272-2-48	52" x 72"	2,000	48"	77" x 79" x 24"	3045	4,799.00
ZLTT-5272-4-48	52" x 72"	4,000	48"	77" x 79" x 24"	3129	5,979.00

FOOT CONTROL, MODEL ZLTT-FC, \$289.00 LIST

RAISED HEIGHT NOTED WITH PLATFORM IN LEVEL POSITION

DC-20/FC-100

## Single Scissor Lift & Tilt Tables

Designed to position containers within easy reach of assembly line workers and machine operators. This unique design reduces fatigue by minimizing repetitive bending and stretching required to obtain components from containers. 96" x 48" unit accommodates (2) 48" x 48" containers, ideal for parts transfer and assembly. Platform includes a 12" high lip on tilt side. A selector pedal allows the operator to lift while tilting, or tilt then lift. 2HP, 208-230/460V, 3-phase, 60 Hz totally enclosed motor is standard, other voltages available. Other standard features include: a two-button handheld control, integrated maintenance lock, pressure plated pump, pressure compensated flow valve, lowering valve, independent oil return, and an adjustable upward travel limit switch. Unit must be lagged to floor.

MODEL NUMBER	PLATFORM SIZE (W x L)	CAPACITY (POUNDS)	LEVEL HEIGHT	MAXIMUM TILT	POWER UNIT	NET WT. (POUNDS)	LIST PRICE EACH
UNI-4848-4	48" x 48"	4,000	8"	40°	INTERNAL	792	\$2,703.00
UNI-5448-4	54" x 48"	4,000	8"	40°	INTERNAL	870	2,929.00
UNI-9648-4	96" x 48"	4,000	8"	40°	INTERNAL	1584	4,518.00
UNI-4848-6	48" x 48"	6,000	8"	40°	INTERNAL	915	\$3,920.00
UNI-5448-6	54" x 48"	6,000	8"	40°	INTERNAL	950	4,204.00

AIR BAG UNI-TILT AVAILABLE, CONTACT FACTORY

THREE SIDED ACCORDION SKIRT AVAILABLE, CONTACT FACTORY

DC-20/FC-70

## Portable Uni-Tilts

Now you can transport your tilter from workstation to workstation quickly and easily with a fork truck. This unique design reduces fatigue by minimizing repetitive bending and stretching required to obtain components from containers. Platform includes a 12" high lip on tilt side. A selector pedal allows the operator to lift while tilting or tilt then lift. 2HP, 208-230/460V, 3PH AC power unit with hand pendant control is standard, other voltages available. Features the same standard features as our original Single Scissor Lift and Tilt Table above.

MODEL NUMBER	PLATFORM SIZE (W x L)	CAPACITY (POUNDS)	LEVEL HEIGHT	MAXIMUM TILT	POWER UNIT	NET WT. (POUNDS)	LIST PRICE EACH
UNI-P-4848-4	48" x 48"	4,000	12"	40°	INTERNAL	1197	\$3,492.00
UNI-P-5448-4	54" x 48"	4,000	12"	40°	INTERNAL	1241	3,643.00

USABLE FORK POCKETS ARE 7½"W x 2½"H

DC-20/FC-70

## Lift & Tilt Workstation Tables

Design of unit allows platform to lift & tilt at the same time for easy operation. Maximum tilt angle is 45° for better ergonomics and operator comfort. Service height range is 10" to 24" (to lowest point of platform surface). Platform end includes 12" high full-width lip to support containers. Internal power unit includes electric motor, hydraulic pump, and control box. Operates with 24V AC hand control on 8 ft. cord. Choose 115/230V single phase or 208/230/460V three phase power. Welded steel construction with yellow painted finish.

MODEL NUMBER	PLATFORM SIZE (W x L)	CAPACITY (POUNDS)	MAXIMUM TILT	NET WT. (POUNDS)	LIST PRICE EACH
ULTT-3648-2	36" x 48"	2,000	45°	860	\$3,088.00
ULTT-4848-2	48" x 48"	2,000	45°	1060	3,103.00
ULTT-5448-2	54" x 48"	2,000	45°	1095	3,126.00
ULTT-3648-4	36" x 48"	4,000	45°	940	\$3,590.00
ULTT-4848-4	48" x 48"	4,000	45°	1110	3,602.00
ULTT-5448-4	54" x 48"	4,000	45°	1140	3615.00
ULTT-3648-6	36" x 48"	6,000	45°	1120	\$4,043.00
ULTT-4848-6	48" x 48"	6,000	45°	1330	4,058.00
ULTT-5448-6	54" x 48"	6,000	45°	1360	4,084.00

FOOT CONTROL, MODEL ULTT-FC, \$88.00 LIST

DC-20/FC-70

## Hinge & Sliding Tilt Tables

Hinge and Sliding Tilt Tables offer the rugged durability of the standard Efficiency Master line of tilters, plus they offer an extra low platform height. A 12" lip without side gussets allows for loading and unloading on three sides. Standard features include a 2 HP 208-230/460V AC power unit with a 24 volt two button hand held pendant control, other voltages available. A pressure plated pump coupled to an application specific manifold features counterbalanced valves and modulated flow control for maximum efficiency.

The Sliding Tilt Table incorporates a patented sliding link-tilt design for maximum stability while occupying minimum space. As the table is tilted, the front edge of the container moves away from the operator. The center-of-gravity of the load remains closer to the center of the frame.

MODEL NUMBER	DESIGN	PLATFORM SIZE (W x L)	CAPACITY (POUNDS)	LEVEL HEIGHT	MAXIMUM TILT	NET WT. (POUNDS)	LIST PRICE EACH
EHTT	HINGE	48" x 48"	4,000	10"	45°	1427	\$2,777.00
EHTT-L	SLIDING	48" x 48"	4,000	8"	45°	1449	2,975.00

THREE SIDED ACCORDION SKIRT AVAILABLE, CONTACT FACTORY

DC-20/FC-70+

HINGE TILT model EHTT

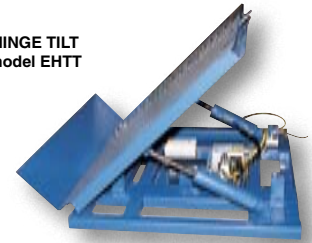

SLIDING TILT model EHTT-L



## Efficiency Master Tilt Tables

The model EM1-200 tilts pallets, crates, boxes, or baskets 45° to facilitate easy container loading or unloading. Tables feature all welded steel construction for years of durability. Unique design minimizes pinch points to meet OSHA requirements. Units are equipped with an industrial quality, 56 frame 2 HP motor. This motor delivers best torque with minimal amperage draw for maximum life. Standard voltage is 208-230/460V 3 phase, other voltages available. A 24V push button hand control is standard.

The model EM1-500 incorporates all of the same quality features found in the Series EM1-200 but features a full 90° of tilt. Unit is ideal for upending products in shipping and receiving operations. Standard with double acting cylinder for controlled tilt and return. Unit must be lagged to floor.

48 Hours to Ship



DVD or VIDEO AVAILABLE

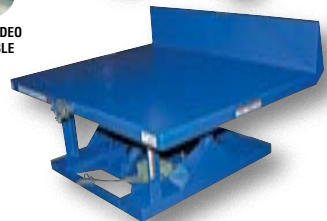

45° EFFICIENCY MASTER features a 12" high lip series EM1-200

### QUICKSHIP (460V 3 PHASE ONLY)

MODEL NUMBER	USABLE SIZE (W x L)	CAPACITY (POUNDS)	MAXIMUM TILT	HORIZONTAL HEIGHT	NET WT. (POUNDS)	LIST PRICE EACH
EM1-200-4848-2	48" x 48"	2,000	45°	24"	741	\$2,408.00
EM1-200-4848-4	48" x 48"	4,000	45°	24"	793	2,553.00

OTHER VOLTAGES ADD \$160.00 LIST & ONE ADDITIONAL WEEK TO LEAD TIME, model EM-VCC

DC-20/FC-70+

MODEL NUMBER	USABLE SIZE (W x L)	CAPACITY (POUNDS)	MAXIMUM TILT	HORIZONTAL HEIGHT	NET WT. (POUNDS)	LIST PRICE EACH
EM1-200-4250-2	42" x 50"	2,000	45°	24"	710	\$2,382.00
EM1-200-6050-2	60" x 50"	2,000	45°	24"	804	2,439.00
EM1-200-4250-4	42" x 50"	4,000	45°	24"	750	\$2,520.00
EM1-200-6050-4	60" x 50"	4,000	45°	24"	854	2,577.00
EM1-200-4250-6	42" x 50"	6,000	45°	24"	792	\$2,771.00
EM1-200-4848-6	48" x 48"	6,000	45°	24"	802	2,837.00
EM1-200-6050-6	60" x 50"	6,000	45°	24"	882	2,876.00
EM1-500-4250-2	42" x 50"	2,000	90°	24"	734	\$2,492.00
EM1-500-4848-2	48" x 48"	2,000	90°	24"	827	2,516.00
EM1-500-6050-2	60" x 50"	2,000	90°	24"	968	2,547.00
EM1-500-4250-4	42" x 50"	4,000	90°	24"	784	\$2,893.00
EM1-500-4848-4	48" x 48"	4,000	90°	24"	850	2,919.00
EM1-500-6050-4	60" x 50"	4,000	90°	24"	1008	2,948.00
EM1-500-4250-6	42" x 50"	6,000	90°	24"	835	\$3,099.00
EM1-500-4848-6	48" x 48"	6,000	90°	24"	866	3,130.00
EM1-500-6050-6	60" x 50"	6,000	90°	24"	1092	3,169.00

OPTIONAL FOOT CONTROL, model EM-FC, \$88.00 LIST

DC-20/FC-70+

**LINE-X**  
Custom Finish Available

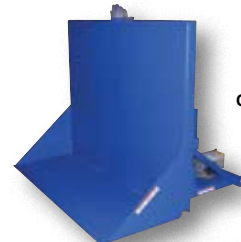

90° EFFICIENCY MASTER features a 24" high lip series EM1-500

### EFFICIENCY MASTER TILT TABLE OPTIONS

MODEL NUMBER	DESCRIPTION	LIST PRICE EACH
<b>45° TILTERS</b>		
EM1-300-APPB	*HAND HELD CONTROL AIR POWERED HYDRAULIC 2.8 HP 1 GPM (ROTARY)	ADD \$634.00
EM1-300-APFC	*FOOT CONTROL AIR POWERED HYDRAULIC 2.8 HP 1 GPM (ROTARY)	ADD \$810.00
EM1-300-APFT	*FOOT TREADLE AIR POWERED 2000# & 4000# ONLY (RECIPROCATING)	DEDUCT \$150.00
<b>90° TILTERS</b>		
EM1-600-APPB	*HAND HELD CONTROL AIR POWERED HYDRAULIC 2.8 HP 1 GPM (ROTARY)	ADD \$690.00
EM1-600-APFC	*FOOT CONTROL AIR POWERED HYDRAULIC 2.8 HP 1 GPM (ROTARY)	ADD \$886.00

\*FILTER REGULATOR - LUBRICATOR REQUIRED TO OPERATE UNIT (WARRANTY VOID WITHOUT)



DVD or VIDEO AVAILABLE

**LINE-X**  
Custom Finish Available



## Ground Tilter

The Ground Tilter is the best product for tilting applications which require the use of a pallet truck for loading and unloading. Rotate containers up to 45° from floor level to provide better access to parts in containers. Platform includes a 17" high lip on tilt side. A removable positioning bar is provided for use with smaller containers. Designed with worker safety in mind, pinch point guards are provided on all four sides of the unit. 2HP, 208-230/460V motor standard, other voltages available. Remote power unit with a protective cover measures 24"W x 24"L x 8"H. Hand pendant control standard. Optional foot control available.

MODEL NUMBER	PLATFORM SIZE (W x L)	CAPACITY (POUNDS)	LEVEL HEIGHT	MAXIMUM TILT	POWER UNIT	NET WT. (POUNDS)	LIST PRICE EACH
GLT-4000	48" x 50"	4,000	1/2"	45°	EXTERNAL	1315	\$3,359.00

FOOT CONTROL, MODEL GLT-FC, \$88.00 LIST

DC-20/FC-70+



POWDER COATED TOUGH

## Bench Top Tilters

Heavy-duty steel Bench Top Tilters tilt loads from 0° to 45° (3" lip). Easily attached to most industrial table tops, work benches, and mobile lift tables of sufficient load capacity and surface size. Unit slides back as it tilts to maintain the center of gravity over the frame. Manual units need to be adjusted only when unloaded. Linear Actuated units are equipped with a push-button hand pendant control, located on an 8 foot cord. Flat base plate with slotted holes for installation.

MODEL NUMBER	PLATFORM SIZE (W x L x H)	CAPACITY (POUNDS)	MAXIMUM TILT	OPERATION	NET WT. (LBS.)	LIST PRICE EACH
BTT-6-36	28" x 36" x 2"	600	15°, 30° & 45°	MANUAL	60	\$133.00
BTT-6-46	28" x 46" x 2"	600	15°, 30° & 45°	MANUAL	72	144.00
BTT-5-36	28" x 36" x 5"	500	0° TO 45°	LINEAR ACTUATED	84	\$893.00
BTT-5-46	28" x 46" x 5"	500	0° TO 45°	LINEAR ACTUATED	96	904.00
BTT-10-36	28" x 36" x 3"	1,000	0° TO 45°	LINEAR ACTUATED	96	955.00
BTT-10-46	28" x 46" x 3"	1,000	0° TO 45°	LINEAR ACTUATED	108	965.00

DC-25/FC-70+



## Air Corner Tilters

The floor level airbag powered tilter provides ergonomic loading and unloading of bulk containers, gaylords, or crates. Pallet truck and fork truck accessible. Tilts up to 45°. Activated by a hand operated control lever or foot pedal. By adjusting the air regulator to a predetermined pressure, the air bag inflates tilting the container automatically as it is unloaded. As the container becomes lighter, it automatically tilts and the material shifts to the corner of the container where it can be easily removed by manual or mechanical means. The adjustable regulator is factory preset to begin rotating the container when the weight reaches approximately 900 lbs. Pressure is easily adjustable for the weight of your application.

MODEL NUMBER	DESCRIPTION	PLATFORM SIZE (W x L)	CAPACITY (POUNDS)	NET WT. (POUNDS)	LIST PRICE EACH
AIR-THL	HAND LEVER OPERATION	44" x 44"	1,500	460	\$1,896.00
AIR-TFP	FOOT TREADLE OPERATION	44" x 44"	1,500	460	1,896.00
AIR-PVO	POWER VIBRATOR OPTION	--	--	30	\$572.00

DC-20/FC-100+

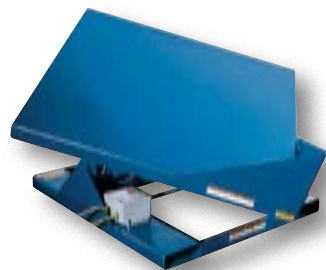

## Electric/Hydraulic Corner Tilters

Reduce repetitive motion injuries and fatigue while making your job easier and faster. Designed to corner tilt pallets, crates, boxes, or baskets 30°. AC powered with 2HP motor, 208-230/460V 3 phase with a push button control, other voltages available. Built in fork tubes for easy portability with a fork truck.

MODEL NUMBER	PLATFORM SIZE (W x L x H)	CAPACITY (POUNDS)	MAXIMUM TILT	NET WT. (POUNDS)	LIST PRICE EACH
EMC-4242-2	42" x 42" x 24"	2,000	30°	750	\$2,408.00
EMC-4242-4	42" x 42" x 24"	4,000	30°	800	2,553.00
EMC-4848-2	48" x 48" x 24"	2,000	30°	800	\$2,515.00
EMC-4848-4	48" x 48" x 24"	4,000	30°	850	2,659.00

FOOT CONTROL, MODEL EMC-FC, \$88.00 LIST

DC-20/FC-100+

## Manual Tilt Master

Lift, tilt, and transport crates, boxes, and pallets with an open bottom. Designed to give the user an ergonomically correct position to reach loads easily without the need for bending down or excessively reaching over. Forks can be tilted to 90°. Rolls smoothly on 6" x 2" polyurethane swivel casters with brake and foot protectors. Width between forks is 9½". The overall fork width is 22". The individual fork width is 6½".



SKID ONLY

NO PALLET

MODEL NUMBER	CAPACITY (POUNDS)	VERTICAL LIFT HEIGHT	LOWERED FORK HEIGHT	FORK LENGTH	OVERALL WIDTH	NET WT. (POUNDS)	LIST PRICE EACH
TM-22-M	2,200	11¼"	3½"	31½"	25¼"	425	\$1,349.00

DC-25/FC-70+



## Tilt Master & Tilt Master Straddle

Lift and position filled tote boxes or baskets without the need of a fork truck or lift table using the newly designed heavy-duty Tilt Master. These 90° tilters will function as transporters by moving completed products from work station to work station without waiting for a fork truck.

A folding ergonomic handle for quick and easy maneuverability. Unit has a thin profile to allow the user to get as close to the load as possible. Units roll easily on 8" x 3" phenolic steering wheels. Floor lock standard. Series TM is designed to be used with open bottom pallets or skids only while the Tilt Master Straddle units, series TMS, can be used with virtually any kind of container or pallet. Units are powered with a 12V DC electric motor including an on-board battery charger standard. AC or \*AIR/OIL power units available contact factory (\*filter - regulator - lubricator required). Units come standard with a push-button hand control on an 8 foot coil cord.



**TILT MASTER**  
With Only 10½" of Reach

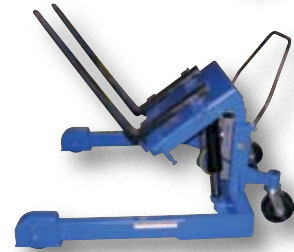

**TILT MASTER STRADDLE**  
With Only 13½" of Reach

TILT MASTER & TILT MASTER STRADDLE OPTIONS			
MODEL NUMBER	DESCRIPTION	NET WEIGHT (POUNDS)	LIST PRICE EACH
TM-CHUTE	RETROFIT CHUTE OPTION	18	\$197.00
TM-PTDS	POWER TRACTION DRIVE SYSTEM	156	4,111.00
TM-BCI	BATTERY CHARGE INDICATOR GAUGE	10	75.00

MODEL NUMBER	CAPACITY (POUNDS)	FORK ADJUSTMENT	OPERATOR REACH	FORK WIDTH	ROTATED HEIGHT	LOWERED HEIGHT	OVERALL SIZE (W x L x H)	NET WEIGHT (POUNDS)	LIST PRICE EACH
<b>TILT MASTER</b>									
TM-20	2,000	FIXED AT 26" (OD)	10½"	6"	33"	3-5/8"	40½" x 68" x 28½"	715	\$2,816.00
TM-40	4,000	FIXED AT 26" (OD)	10½"	6"	33"	3-5/8"	40½" x 68" x 28½"	770	3,118.00
TM-60	6,000	FIXED AT 27" (OD)	10½"	6½"	33"	3-5/8"	40½" x 68" x 28½"	851	4,007.00
<b>TILT MASTER STRADDLE</b>									
TMS-20	2,000	½" TO 29½" (ID)	13½"	4"	37"	2-5/8"	57" x 61" x 28½"	840	\$3,102.00
TMS-40	4,000	½" TO 29½" (ID)	13½"	4"	37"	2-5/8"	57" x 61" x 28½"	1155	3,336.00
TMS-60	6,000	½" TO 29½" (ID)	13½"	4"	37"	2-5/8"	57" x 61" x 28½"	1365	4,201.00

DC-25/FC-70♦

## Portable Pallet Inverter

Tilt and rotate loads with our durable Pallet Inverter. Low profile design allows the operator to stand on the rider platform and steer the load from workstation to workstation quickly and easily. DC power lift and drive makes operation safe and efficient. Features an on-board battery charger (AC 110V or 220V/60 Hz). Ideal in loading dock areas as a power pallet truck, pallet tilter or as a turntable.

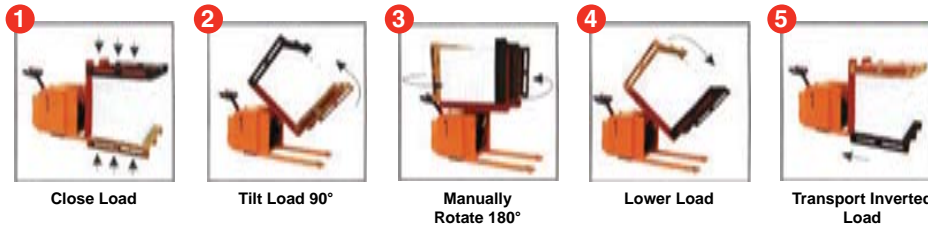
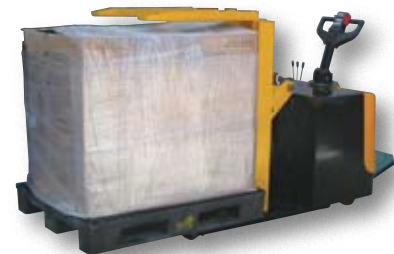

MODEL NUMBER	CAPACITY (POUNDS)	FORK OPENING (MIN & MAX)	LOWERED HEIGHT	FORK (W x L)	OVERALL SIZE (W x L x H)	NET WT. (POUNDS)	LIST PRICE EACH
PPI-90	2,000	31½" to 47½"	3½"	6" x 30"	33½" x 78" x 54"	1650	\$12,495.00

DC-20/FC-70♦

## Pallet Inverters

Engineered to reduce your costs in production, storage, retrieval, and distribution. The 180° rotation makes pallet exchange quick and simple while reducing product damage. Easy load transfer from wood pallet to plastic pallet, slip sheet, or rental pallet. Features safety rails and guards. Units can be loaded and unloaded easily with a fork truck.

MODEL NUMBER	MAXIMUM LOAD SIZE (W x L)	MINIMUM JAW OPENING HEIGHT	MAXIMUM JAW OPENING HEIGHT	CAPACITY (POUNDS)	NET WT. (POUNDS)	LIST PRICE EACH
PI-51	50" x 50"	37"	61"	4,400	4048	\$33,937.00
PI-61	50" x 50"	43"	73"	4,400	4268	35,382.00

LEVER CONTROL STANDARD / NEMA 12 RATING STANDARD

DC-20/FC-70♦





DVD or VIDEO AVAILABLE

45° DUMP ANGLE  
(135° TOTAL ROTATION)  
model HBD-2-48



Custom Finish Available



## Electric/Hydraulic Box Dumpers

Designed for controlled dumping of material from boxes, crates, and other types of containers. Lowered height of only 3/8" allows for pallet truck loading and unloading. Retaining bar for use with 24", 30", and 36" high containers (contact factory for other hold-down bar heights). Maximum rotation is 135°. Chute reach is 10" when fully rotated. Internal 2HP power unit and hand held control standard (5HP power unit on 6,000 lbs. models). Protective mesh side screens included. Heavy-duty welded steel construction.

MODEL NUMBER	DUMP HEIGHT	LEVEL HEIGHT	USABLE CHUTE (W x L)	ROTATED HEIGHT	CAPACITY (POUNDS)	OVERALL (W x L)	NET WT. (POUNDS)	LIST PRICE EACH
HBD-2-36	36"	53"	51½" x 50"	108"	2,000	64" x 67"	1564	\$4,472.00
HBD-2-48	48"	65"	51½" x 50"	128"	2,000	64" x 67"	1701	4,623.00
HBD-2-60	60"	77"	51½" x 50"	148"	2,000	64" x 67"	1837	4,730.00
HBD-4-36	36"	53"	51½" x 50"	108"	4,000	67" x 67"	1653	\$5,514.00
HBD-4-48	48"	65"	51½" x 50"	128"	4,000	67" x 67"	1748	5,689.00
HBD-4-60	60"	77"	51½" x 50"	148"	4,000	67" x 67"	1932	5,780.00
HBD-6-36	36"	53"	51½" x 50"	108"	6,000	67" x 67"	1748	\$5,803.00
HBD-6-48	48"	65"	51½" x 50"	128"	6,000	67" x 67"	1837	5,952.00
HBD-6-60	60"	77"	51½" x 50"	148"	6,000	67" x 67"	2021	6,075.00

OPTIONAL FOOT CONTROL, model HBD-FC, \$88.00 LIST

DC-20/FC-100♦

## Fork Truck Mounted Trash Can Dumper

Save time and reduce work-related injuries caused by lifting and dumping heavy waste containers. This innovative product will allow a fork truck driver to lift and dump refuse containers weighing up to 1,000 lbs. without ever leaving the seat of the fork truck! Secure dumper to fork truck with safety chain and run cable to driver's seat. Align trash can with dumper and lock into place. Once locked in place, transport trash can to refuse container, align, and pull chain to dump refuse container contents. Only for use with 64 gallon trash can, model TH-64, or approved equal. Fork pockets are 2¼" high by 7¼" wide usable. Steel construction for years of dependable use.

MODEL NUMBER	DESCRIPTION	OVERALL SIZE (W x L x H)	CAPACITY	NET WT. (POUNDS)	LIST PRICE EACH
FM-T-DUMP	FORK TRUCK DUMPER	40" x 52" x 41"	1,000 lbs.	400	\$782.00
TH-64	TRASH CAN	23" x 29" x 41"	65 gal.	55	\$77.10

DC-20/FC-70♦

## Manual & Electric Hydraulic Trash Can Dumpers

Trash Can Dumper is designed so one person can easily dump contents of trash cans no matter how heavy they are. Versatile adjustable unit works with only the trash cans listed below or approved equal. Available in manual foot pump, or in AC or DC powered operation with hand control. DC powered units include an on-board battery charger. Heavy-duty steel construction with two rigid and two swivel casters for portability. Maximum dump angle is 135°.

MODEL NUMBER	DESCRIPTION	MAXIMUM DUMP ANGLE	MAXIMUM DUMP HEIGHT	CAPACITY (POUNDS)	NET WT. (POUNDS)	LIST PRICE EACH
TCD-M	FOOT PUMP	135°	48"	400	386	\$2,104.00
TCD-AC	115V AC POWERED	135°	48"	400	400	2,926.00
TCD-DC	12V DC POWERED	135°	48"	400	420	2,926.00
BC	REMOTE BATTERY CHARGER				8	\$122.50
BCI	BATTERY CHARGE INDICATOR GAUGE				1	75.00
TRASH CANS						
TH-32	32 GALLON GREEN (18½"W x 22"D x 37½"H)				35	\$57.70
TH-64	64 GALLON GRAY (23"W x 29"D x 41"H)				55	77.10
95-GLT	95 GALLON BLUE (27"W x 34"D x 45"H)				50	167.00

DC-20/FC-100♦/TRASH CANS, model TH, FC-70/TRASH CAN, model 95-GLT, FC-100

## Trash Can Dumpers

Minimize lifting and dumping heavy trash cans with the rugged all steel Trash Can Dumper. One person can easily and safely empty trash cans weighing up to 300 lbs. into dumpsters. The automatic container clamp securely holds the trash can container. Hand crank or 115V, 1 phase, push button actuation rotates containers to 135° angle (60" dump height) above dumpster. Each unit comes with four casters for easy maneuverability and heavy-duty mesh sides for safety. One Trash Can, model 95-GLT, comes standard with each unit.

MODEL NUMBER	DESCRIPTION	OVERALL SIZE (W x L x H)	NET WT. (POUNDS)	LIST PRICE EACH
T-DUMP-E	115V PUSH BUTTON ELECTRIC WINCH	42½" x 61" x 79"	1210	\$2,100.00
T-DUMP-HC	HAND OPERATED WINCH WITH BRAKE	42½" x 61" x 79"	1150	1,968.00
95-GLT	ADDITIONAL 95 GALLON POLY TOTE SPECIFY BLUE, BROWN, GRAY OR GREEN	27" x 34" x 45½"	50	\$167.00

THE T-DUMP SERIES HAS A DUMP HEIGHT OF 60" AND A DUMP ANGLE OF 135°

DC-20/FC-100♦

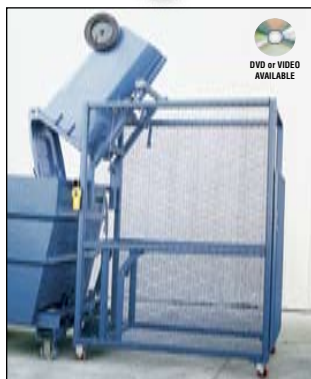

DVD or VIDEO AVAILABLE



## Mobile Tilting Work Tables

Designed to bring work to an ergonomically correct position, helping to foster a more comfortable and productive work environment. Working in a comfortable position also reduces fatigue and risk of injuries. Platform height and tilt angle are manually adjustable, with the exception of model WT-2424-LA, which uses an electric linear actuator with a hand control and 115V AC motor. Four 3½" x 1¼" polyurethane swivel casters (two double locking) allow unit to be transported from one work area to another while loaded. All steel construction.

MODEL NUMBER	PLATFORM SIZE (W x L)	LIP HEIGHT	SERVICE RANGE*	PLATFORM TILT	CAPACITY (POUNDS)	NET WT. (POUNDS)	LIST PRICE EACH
WT-2424	24" x 24"	3"	31½" to 42"	30°	300	120	\$524.00
WT-2221	22" x 21"	2"	28" to 38"	45°	150	85	225.00
WPT-1624	16" x 24"	2"	31½" to 42"	45°	200	60	220.00
WT-2424-LA	24" x 24"	3"	31½" to 42"	30°	300	135	1,631.00

\*SERVICE RANGE WITH PLATFORM IN LEVEL POSITION



DC-25/FC-70♦

**LINE-X**  
Custom Finish Available

## Hydraulic Work Positioner

Ideal for either sitting or standing applications at work assembly areas. Lip retains plastic bins and organizers. Spring loaded detent controls the tilt angle. Hydraulic foot pump with a telescoping cylinder provides a 14" service range.

MODEL NUMBER	PLATFORM SIZE (W x L)	LIP HEIGHT	SERVICE RANGE*	PLATFORM TILT	CAPACITY (POUNDS)	NET WT. (POUNDS)	LIST PRICE EACH
WT-2016-FP	20" x 16"	1¼"	28¾" to 42"	40°	330	89	\$269.00

\*SERVICE RANGE WITH PLATFORM IN LEVEL POSITION

DC-25/FC-70♦

## Deluxe Roller Stands

Designed for use as an extra hand when working with long materials. Each stand includes chrome plated rollers and heavy-duty cast-steel base. Choose either v-groove roller design or flat single roller design. The height of each stand is adjusted with a friction lock screw. Great for use in machine and wood shops.

MODEL NUMBER	DESCRIPTION	VARIABLE HEIGHT SERVICE RANGE	CAPACITY (POUNDS)	NET WT. (POUNDS)	LIST PRICE EACH
STAND-H	14" HORIZONTAL ROLLER	23" to 38½"	1,760	66	\$81.00
STAND-V	(2) 5" "V" ROLLERS (9"W ACROSS)	23" to 38½"	1,760	66	81.00
STAND-H-HP	14" HORIZONTAL ROLLER	27" to 42"	1,760	75	\$85.00
STAND-V-HP	(2) 5" "V" ROLLERS (9"W ACROSS)	27" to 42"	1,760	75	85.00

DC-20/UPS/FC-85

## Transportable Stacker

This stacker will allow you to lift and move boxes and containers with ease. The unique design will also allow you to load it into the back of your truck or van without the need for heavy lifting or an overhead crane. To load into your truck, raise forks above truck bed and push the unit forward completely over truck bed. Push the lower button and hydraulic system will lower forks to truck bed and then begin to raise the rest of the stacker automatically! Features 12V DC battery power with push-button operation. Includes two rigid and two swivel casters. Steel construction.

MODEL NUMBER	OVERALL SIZE (W x L x H)	CAPACITY (POUNDS)	SERVICE RANGE	NET WT. (POUNDS)	LIST PRICE EACH
T-LIFTER	38½" x 63" x 56¼"	1,000	3½" x 43"	700	\$3,468.00

FORK SIZE: 23¼" W x 46" L (INDIVIDUAL FORK WIDTH IS 6½")

DC-20/FC-100/150♦

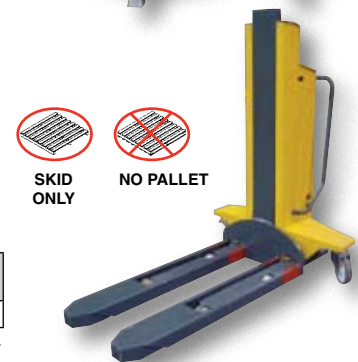

## Electric Order Picker

Reduce strain while increasing safety and productivity during repeated order picking applications. Manually pushed unit is easy to position. The lift operates with a 12V DC battery. Includes an on-board charger. The material platform measures 21½" wide by 23½" deep. Dual interlocking hand controls require the operator to have both hands on the hand rails during raising and lowering.

MODEL NUMBER	OVERALL SIZE (W x L x H)	SERVICE RANGE	TOTAL CAPACITY	NET WT. (POUNDS)	LIST PRICE EACH
EOP-440	24¾" x 47½" x 41"	26" to 59"	440 lbs.	333	\$2,739.00

DC-25/FC-70







DVD or VIDEO AVAILABLE

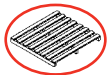

SKID ONLY

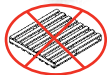

NO PALLET

APPLIES TO ALL PRODUCTS ON THIS PAGE

## High Rise Lift Trucks

Ergonomic lift truck increases worker and machine efficiency and productivity. Reduces muscle fatigue and body injuries by bringing material closer to actual worker height. 12V DC power with on-board battery charger standard. Heavy loads can be lifted by electric hydraulic power and manually moved until auto brake engages at approximately 8". Push buttons to raise and lower lift are located on power unit. Key-operated ON/OFF control for better security is built into the power unit. Unit rolls smoothly on phenolic 3" x 8" rear swivel casters and 3" x 2" front guide wheels.

MODEL NUMBER	FORK SIZE (W x L)	SERVICE RANGE	CAPACITY (POUNDS)	OPERATION	NET WT. (POUNDS)	LIST PRICE EACH
HIPM-2748	27" x 48"	3½" to 31"	2,500	DC BATTERY	530	\$1,972.00
HIPM-2048	20" x 48"	3½" to 31"	2,500	DC BATTERY	515	2,036.00

DC-20/FC-70♦

### HIGH RISE LIFT TRUCK OPTIONS

MODEL NUMBER	DESCRIPTION	NET WT. (POUNDS)	LIST PRICE EACH
HIPM-PLATE	SOLID PLATFORM TO FIT OVER FORKS	36	\$203.00
HIPM-FC	FOOT TREADLE AIR/HYDRAULIC OIL OPTION	24	NO CHARGE*
HIPM-AC	24V HAND HELD CONTROL, 115V AC POWER OPTION	48	NO CHARGE*
HIPM-PTDS	POWER TRACTION DRIVE SYSTEM (OVERALL WIDTH 40")	156	4,111.00
HIPM-BCI	BATTERY CHARGE INDICATOR GAUGE (DC UNITS ONLY)	1	75.00
HIPM-FLK	MANUAL FLOOR LOCK	15	185.00

## Tote Lifters

Designed to lift open bottom skids, boxes, and baskets. Two operations available: hand pump and 12V DC power with rocker switch to raise or lower. Hand pump design features an ergonomic pump handle with two lifting speeds to accommodate for light or heavy loads. Side stabilizers provide balance to the unit when the load is lifted. Suffix "SS" stands for stainless steel units. Stainless steel units feature nylon wheels.



DVD or VIDEO AVAILABLE

HAND PUMP  
L-220-HD & L-270-HD



12V DC POWERED  
L-220-DC-HD &  
L-270-DC-HD

MODEL NUMBER	OPERATION	FORK SIZE (W x L)	SERVICE RANGE	CAPACITY (POUNDS)	NET WT. (POUNDS)	LIST PRICE EACH
L-220-HD	HAND PUMP	20" x 43"	3½" to 31½"	3,000	320	\$787.00
L-270-HD	HAND PUMP	27" x 43"	3½" to 31½"	3,000	340	798.00
L-270-HD-SS	HAND PUMP	27" x 45"	3½" to 31½"	3,000	340	2,610.00
L-220-DC-HD	12V DC POWERED	20" x 45"	3½" to 31½"	3,000	253	\$1,671.00
L-270-DC-HD	12V DC POWERED	27" x 45"	3½" to 31½"	3,000	427	1,738.00
L-270-DC-HD-SS	12V DC POWERED	27" x 45"	3½" to 31½"	3,000	427	3,426.00

DC-25/FC-70♦

### TOTE-LIFTER OPTIONS

MODEL NUMBER	DESCRIPTION	NET WT. (POUNDS)	LIST PRICE EACH
BC	REMOTE BATTERY CHARGER	8	\$122.50
BC-OB	ON-BOARD BATTERY CHARGER	9	195.00
BCI	BATTERY CHARGE INDICATOR GAUGE	1	75.00
L-PLATE-20	SOLID PLATFORM TO FIT OVER FORKS (20" Wide Unit)	36	\$213.00
L-PLATE-27	SOLID PLATFORM TO FIT OVER FORKS (27" Wide Unit)	37	213.00



STAINLESS STEEL  
12V DC POWERED  
L-270-DC-HD-SS



DVD or VIDEO AVAILABLE

FOOT PUMP  
model TAL-260-HD

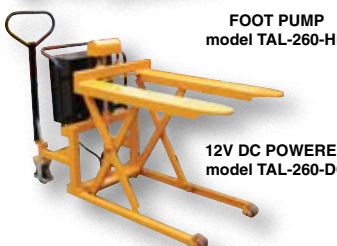

12V DC POWERED  
model TAL-260-DC

## Tote-A-Loads

Designed to lift open bottom skids, boxes, and baskets. The manually operated lift is easy to operate. The foot pump operated lift travels approximately 1/2" per stroke. To lower unit simply squeeze the bicycle style grip located on the white push bar. The battery operated lift is ideal for positioning products at workstation height for increased productivity. The up/down lever control is conveniently located on power unit. DC powered units include on-board charger. Polyurethane swivel casters with brake are standard on all units.

MODEL NUMBER	DESCRIPTION	FORK SIZE (W x L)	CAPACITY (POUNDS)	SERVICE RANGE	NET WT. (POUNDS)	LIST PRICE EACH
TAL-220-HD	FOOT PUMP	21" x 43"	2,200	3½" to 33"	315	\$770.00
TAL-260-HD	FOOT PUMP	27" x 43"	2,200	3½" to 33"	336	776.00
TAL-220-DC	12V DC POWERED	21" x 43"	2,200	3½" to 33"	415	\$1,679.00
TAL-260-DC	12V DC POWERED	27" x 43"	2,200	3½" to 33"	440	1,684.00

DC-20/UPS/FC-70

### TOTE-A-LOAD OPTIONS

MODEL NUMBER	DESCRIPTION	NET WT. (POUNDS)	LIST PRICE EACH
BC	REMOTE BATTERY CHARGER	8	\$122.50
TAL-PLATE	SOLID PLATFORM TO FIT OVER FORKS	36	\$201.00

## Pallet Master/Servers

Enables one person to easily move fully loaded pallets without the use of a fork truck. Unique straddle design works well with pallets and skids with and without an understructure. Ideal for loading and unloading semi-trailers. 12V DC power standard with on-board charger. Push buttons to raise and lower lift are located on power unit. Hand control on coil cord standard. Key-operated ON/OFF control for better security is built into the power unit. All welded steel construction. Each fork is 4"W x 36"L. Lowered height is 3". Unit moves easily with two rigid and two swivel 8" phenolic casters. Floor lock standard.



DVD or VIDEO AVAILABLE

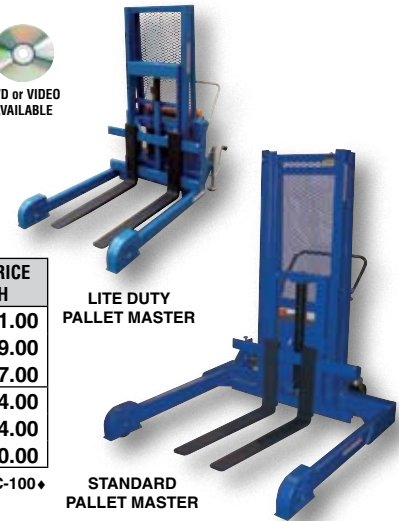

LITE DUTY PALLET MASTER

STANDARD PALLET MASTER

MODEL NUMBER	CAPACITY (POUNDS)	DESCRIPTION	FORK SIZE (W x L)	RAISED HEIGHT	NET WT. (POUNDS)	LIST PRICE EACH
PMPS-50M	2,500	MANUAL FOOT PUMP	4" x 36"	50"	931	\$2,721.00
PMPS-50	4,000	SPECIFY 12V DC, AC or AIR/OIL	4" x 36"	50"	1081	3,069.00
PMPS-60	4,000	SPECIFY 12V DC, AC or AIR/OIL	4" x 36"	60"	1105	3,317.00
LL-PMPS-50*	1,200	SPECIFY 12V DC, AC or AIR/OIL	4" x 36"	50"	860	\$1,964.00
LL-PMPS-60*	1,200	SPECIFY 12V DC, AC or AIR/OIL	4" x 36"	60"	875	2,204.00
LL-PMPS-72*	1,200	SPECIFY 12V DC, AC or AIR/OIL	4" x 36"	72"	910	2,550.00

\* INSIDE STRADDLE WIDTH IS ADJUSTABLE BETWEEN 30" TO 50"

DC-20/FC-100♦

## Counter-Balanced Pallet Master/Servers

Move pallets and skids from one workstation to another with this Counter-Balanced Stacker. Features an 18" horizontal load center and adjustable forks from 8" to 28". Standard 12V DC power lift with on-board charger. Available in AC power or Air/Oil power. Move the unit around easily on its 8" x 3" phenolic casters. Push button pendant control on an 8 foot coil cord is standard on the 12V DC and AC power units.

MODEL NUMBER	CAPACITY (POUNDS)	FORK SIZE (W x L)	SERVICE RANGE	OVERALL HEIGHT (RAISED / LOWERED)	NET WT. (POUNDS)	LIST PRICE EACH
CB-PMPS-6-50	600	4" x 36"	3" to 50"	91" to 73½"	2572	\$2,978.00
CB-PMPS-10-50	1,000	4" x 36"	3" to 50"	91" to 73½"	3439	3,272.00
CB-PMPS-6-60	600	4" x 36"	3" to 60"	101" to 83½"	2608	3,316.00
CB-PMPS-10-60	1,000	4" x 36"	3" to 60"	101" to 83½"	3504	3,610.00

DC-20/FC-100♦



COUNTER-BALANCED PALLET MASTER/SERVER

## Counter-Balanced Stackers

Move small loads from one place to another without the need for oversized fork truck equipment. Counterbalance design allows the operator complete access to three sides of the load. The open front enables the forks to be next to workstation for easy loading and unloading. Standard 12V DC power lift with on-board charger. Includes counterbalance. Push buttons to raise and lower lift are located on power unit. Key-operated ON/OFF control for better security is built into the power unit.

MODEL NUMBER	CAPACITY (POUNDS)	FORK SIZE (W x L)	SERVICE RANGE	OVERALL SIZE (W x L x H)	NET WT. (POUNDS)	LIST PRICE EACH
CBS-64-1	1,000	3" x 25"	2½" to 58"	27" x 62" x 80"	1110	\$2,663.00
CBS-76-1	1,000	3" x 25"	2½" to 76"	27" x 62" x 93"	1206	2,846.00

DC-20/FC-100♦



COUNTER BALANCED STACKER

## Power Traction Drive System Option

Reduce worker fatigue and injury with the Portable Traction Drive Option. This factory installed option is available on portable equipment. An alternative to costly fork trucks, the PTDS includes combination throttle / direction butterfly style controller, an adjustable yoke and auto reverse emergency "belly" switch. This state of the art option allows a single operator to safely and easily move products. Power pack is 42" wide. Maximum speed is 2.5 m.p.h.

MODEL NUMBER	DESCRIPTION	NET WT. (POUNDS)	LIST PRICE EACH
PTDS	POWERED TRACTION DRIVE SYSTEM	156	\$4,111.00

DC-20/FC-100♦



COUNTER-BALANCED PALLET MASTER SERVER W/POWER TRACTION DRIVE

PALLET MASTER/SERVER & STACKER OPTIONS			
MODEL NUMBER	DESCRIPTION	NET WT. (POUNDS)	LIST PRICE EACH
PMPS-DCR	RETROFIT DRUM CARRIER ROTATOR (800# CAPACITY) (SEE PAGE 136 FOR DETAILS)	239	\$563.00
PMPS-BC	BENCH TOP STYLE BATTERY CHARGER	8	122.50
PMPS-BCI	BATTERY CHARGE INDICATOR GAUGE	1	75.00



## Basket & Skid Stackers

Transport open bottom pallets, skids, baskets, and crates with ease. Features an 18" horizontal load center and overall fork width of 37" O.D. . Available in 12V DC power (with on-board charger), AC power or Air/Oil power. Move the unit around easily on its 8" x 3" swivel phenolic rear casters. Handle height is 36". Push buttons to raise and lower 12V DC lift are located on the power unit. Hand control on coil cord standard. Key-operated ON/OFF control for better security is built into the 12V DC power unit.

MODEL NUMBER	CAPACITY (POUNDS)	DESCRIPTION	FORK SIZE (W x L)	SERVICE RANGE	NET WT. (POUNDS)	LIST PRICE EACH
PMSS-50-DC	4,000	12V DC POWER	4" x 36"	3½" to 50"	1058	\$2975.00
PMSS-60-DC	4,000	12V DC POWER	4" x 36"	3½" to 60"	1078	3228.00
PMSS-50-AC	4,000	115V AC POWER	4" x 36"	3½" to 50"	1078	\$2975.00
PMSS-60-AC	4,000	115V AC POWER	4" x 36"	3½" to 60"	1078	3228.00
PMSS-50-AIR	4,000	AIR/OIL POWER	4" x 36"	3½" to 50"	1078	\$2975.00
PMSS-60-AIR	4,000	AIR/OIL POWER	4" x 36"	3½" to 60"	1078	3228.00

DC-20/FC-100+



model HYS-96

## Hydraulic and Winch Stackers

Safe ergonomic alternative to fork trucks at a fraction of the cost. Engineered for smooth operation and outstanding durability, the Hydraulic Stackers handle the following applications: lift and transport skids, bales, and baskets; load/unload trucks, stock shelves, handle dies, molds, or pallets. By combining a power lift with an easy to operate manual push, these Hydraulic Stackers are perfect for maneuvering in tight or congested areas. Complete with on-board charger. Features: 24" horizontal load center, adjustable straddle legs (34" to 50" I.D.), and adjustable forks 6" to 24" (O.D.). 6" swivel phenolic rear casters and 4" phenolic front wheels are standard.

The Compact Winch Stacker is a less expensive ergonomic alternative for lifting pallets of all sizes. This compact unit is perfect for loading/unloading trucks where docks are not available. Features include: safety cage, adjustable straddle legs (34" to 50" I.D.), winch with an automatic braking system, a floor brake to secure unit in place, adjustable forks (6" to 24" O.D.) and 4" swivel phenolic casters/4" phenolic front wheels.

model CWS-60

MODEL NUMBER	OPERATION	SERVICE RANGE	CAPACITY (POUNDS)	OVERALL SIZE (W x L x H)	NET WT. (POUNDS)	LIST PRICE EACH
HYS-60	12V DC	3" to 60"	1,500	40"-56" x 58" x 70"	688	\$3,535.00
HYS-96	12V DC	3" to 96"	1,500	40"-56" x 58" x 69"	855	4,386.00
HYS-144	12V DC	3" to 144"	1,500	40"-56" x 65" x 93½"	925	5,188.00
CWS-60	HAND WINCH	3" to 60"	750	40"-56" x 50" x 70"	408	\$1,706.00

DC-20/FC-175



HAND CRANK

## Manual Work Positioners

These lightweight lifts are designed to take the strain out of any lifting job. Ideal for use in narrow aisles and confined spaces. Platform height is adjustable with a manual hand winch.

An auto brake system allows for controlled lowering. Quick change attachments available - contact factory for details.



V BLOCK

REEL ROTATOR

DOUBLE SPINDLE

SINGLE SPINDLE

MODEL NUMBER	PLATFORM SIZE (W x L)	SERVICE RANGE	CAPACITY (POUNDS)	NET WT. (POUNDS)	LIST PRICE EACH
MWP-220	18½" x 23½"	5¼" to 59"	220	105	\$567.00
MWP-440	18½" x 23½"	5¼" to 59"	440	155	594.00
MWP-VBLK	V BLOCK ATTACHMENT			17	\$71.00
MWP-RR	REEL ROTATOR ATTACHMENT			25	195.00
MWP-DSPIN	DOUBLE SPINDLE ATTACHMENT			11	67.00
MWP-SPIN	SINGLE SPINDLE ATTACHMENT			7	50.00

DC-25/FC-92.5



New

## Versatile Quicklifts

An economical alternative DC powered lift. Ideal for light industrial or commercial applications. Features durable belt over pulley design. This lifter has a high service range and four swivel casters to provide great versatility and convenience. White high density (HDPE) plastic platform is scratch resistant, easy to clean, and retains an attractive appearance. Just 18 seconds for the 57" platform travel. Top wheels facilitate loading into a pick-up or van. Tool tray and remote battery charger is standard.

MODEL NUMBER	PLATFORM SIZE (W x L)	CAPACITY (POUNDS)	SERVICE RANGE	OVERALL SIZE (W x L x H)	CASTERS FRONT/BACK	NET WT. (LBS.)	LIST PRICE EACH
PEL-33	20½" x 18"	330	5-1/8" to 62"	20½" x 33" x 73½"	3" / 4"	128	\$1,903.00
PEL-S	SINGLE SPINDLE					7	\$159.00
PEL-DS	DOUBLE SPINDLE					11	\$181.00

DC-25/FC-92.5



## DC Powered Quick Lifts

Quiet, lightweight units transport and position loads quickly with just the push of a button. Battery operated. High density polyethylene platform makes these lifts ideal for clean room operations. 9" horizontal load center. Features low profile design for maneuvering in narrow aisles and confined spaces. Poly casters; two swivel and two swivel- locking are standard on all units with the exception of the PEL-400 units. The PEL-400 comes standard with rigid front wheels and swivel rear wheels with locks. 24V battery and 110V AC charger. Powder coat blue finish. A detachable handheld control with coil cord for remote operation is optional. The optional Programmable Height Indexing option allows you to preset multiple working heights at the touch of a button.



MODEL NUMBER	PLATFORM SIZE (W x L)	CAPACITY (POUNDS)	SERVICE RANGE	CASTER SIZE	NET WT. (POUNDS)	LIST PRICE EACH
<b>STEEL QUICK LIFTS</b>						
PEL-88	24" x 19"	175	5½" to 57"	3"	225	\$1,804.00
PEL-100	24" x 19"	125	5½" to 72"	3"	230	1,943.00
PEL-400-57	24" x 20"	400	6½" to 57"	4"	440	2,468.00
PEL-400-72	24" x 20"	400	6½" to 72"	4"	460	2,730.00
<b>ALUMINUM QUICK LIFTS</b>						
PEL-88A	24" x 19"	175	5½" to 57"	3"	150	\$1,947.00
PEL-100A	24" x 19"	125	5½" to 72"	3"	226	2,066.00
<b>DC POWERED QUICK LIFT OPTIONS</b>						
PEL-88-AC	OPTIONAL 115V AC POWER OPTION					\$630.00
PEL-400-AC	OPTIONAL 230V AC POWER OPTION					1,260.00
PEL-88-AC/DC	OPERATES ON EITHER 24V DC BATTERY OR 115V 1 PHASE					736.00
PEL-400-AC/DC	OPERATES ON EITHER 24V DC BATTERY OR 230V 1 PHASE					1,329.00
PEL-HC	DETACHABLE HAND PENDANT CONTROL					90.00
PEL-INDEX	PROGRAMMABLE HEIGHT INDEXING					\$1,660.00



Programmable Index, model PEL-INDEX



Standard Push Button Control Panel



110V AC Charger



Detachable Hand Control, model PEL-HC

DC-25/FC-92.5

## Hand Winch Lift Trucks

Compact lift trucks are designed to lift material to and from shelves, move office equipment, and install ceiling/wall appliances. Constructed of durable steel-and-aluminum. The rugged 4" wide by 1¾" thick steel forks measure 20½" wide by 22" long overall. Operated by a hand-crank winch that features a reversible handle and a hold-down device for securing the carriage during transport. Forks can be inverted to provide two different heights. Two 8" non-marking rear wheels, two 2" front swivel casters.

MODEL NUMBER	CAPACITY (POUNDS)	LOWERED HEIGHT	RAISED HEIGHT FORKS DOWN/UP	OVERALL SIZE (W x L x H)	NET WT. (LBS.)	LIST PRICE EACH
<b>STANDARD DESIGN (Fixed Straddle Width: 13" (I.D.) and 21½" (O.D.))</b>						
A-LIFT-R	500	3½" / 23½"	47" / 67"	24" x 35" x 68"	136	\$652.00
A-LIFT-R-HP	400	3½" / 23½"	97" / 117"	24" x 35" x 68"	140	757.00
<b>STRADDLE DESIGN (Adjustable Straddle Width: 21½" to 36" (I.D.) and 29" to 44" (O.D.))</b>						
A-LIFT-S	500	1¼" / 21¼"	47" / 67"	29" x 43" x 68"	140	\$696.00
A-LIFT-S-HP	400	1¼" / 21¼"	97" / 117"	29" x 43" x 68"	145	775.00
A-LIFT-S-EHP	350	1¼" / 21¼"	118" / 142"	29" x 43" x 79"	154	826.00
<b>COUNTERBALANCE DESIGN</b>						
A-LIFT-CB	500	2" / 21¼"	47" / 67"	29" x 47" x 68"	396	\$928.00
A-LIFT-CB-HP	400	2" / 21¼"	97" / 117"	29" x 47" x 68"	418	1,004.00
A-LIFT-CB-EHP	350	2" / 21¼"	118" / 142"	29" x 47" x 79"	449	1,039.00
<b>OPTIONS</b>						
A-LIFT-DK	DECK PLATFORM (not used with CB units)				25	\$82.00
A-LIFT-PN	10" PNEUMATIC REAR WHEELS (not used with CB units)				20	50.00

DC-25/FC-92.5



STRADDLE DESIGN model A-LIFT-S

STANDARD DESIGN model A-LIFT-R

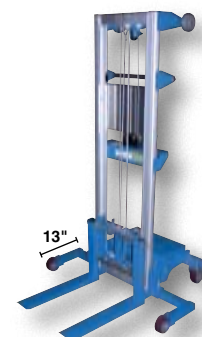

**New**  
COUNTERBALANCED DESIGN model A-LIFT-CB

## Portable Worksite Lift

Ideal for positioning loads where they are needed. Includes a lifting platform and an overhead lifting boom for unique applications. Features manual hand crank cable winch with hook. Portability is easy with 8" x 2" phenolic swivel casters and push handle. Unit knocks-down in two pieces - base and upright. Ideal for storage in tight places and for transportation in the back of a vehicle. Welded steel construction with painted finish. Capacity 500 pounds. Distance between front outriggers is 28".

MODEL NUMBER	OVERALL SIZE (W x L x H)	PLATFORM SIZE (W x L)	PLATFORM SERVICE RANGE	BOOM SERVICE RANGE	BOOM REACH	NET WT. (POUNDS)	LIST PRICE EACH
LIFTER-2	35" x 44" x 91"	20½" x 20"	16" to 71"	0" to 81"	22½"	310	\$978.00

DC-20/FC-92.5





LLW-202058-FW

LLH-202053-FW



ALLW-2020-FW

ALLW-2420-4SFL



ALLPW-500-FW

LLPW-500-FW

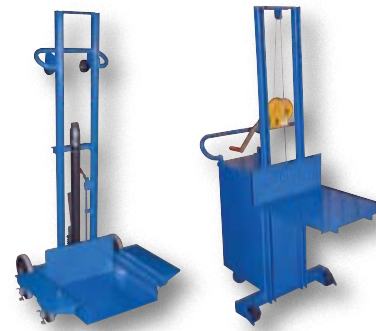

LLPH-500-4SFL

LLCB-202058



## Lite Load Lifts

Lift and transport loads from delivery trucks to docks, or use to inventory items on storage systems. Easy to operate, lifts are available in steel or aluminum construction. Units roll smoothly on 6" x 2" mold-on-rubber rear wheels with 2" semi steel front wheels. Four swivel wheels and floor lock are standard on units with the suffix (-4SFL). Located on the handle are two rollers to ease loading into delivery trucks. The platform lifts approximately 1" per winch rotation or foot pump stroke. Horizontal load center is 10". Low Profile units have a deck height of 1/4" with 2" high side lips.

### LITE LOAD LIFTS

MODEL NUMBER	DESCRIPTION	PLATFORM SIZE (W x L)	SERVICE RANGE	CAPACITY (POUNDS)	NET WT. (POUNDS)	LIST PRICE EACH
<b>STEEL CONSTRUCTION</b>						
LLW-202058-FW	WINCH	20" x 20"	3/4" to 58"	500	145	\$403.00
LLW-242060-4SFL	WINCH	24" x 20"	6/4" to 59"	500	212	582.00
LLH-202053-FW	FOOT PUMP	20" x 20"	3/4" to 53"	500	139	\$627.00
LLH-242056-4SFL	FOOT PUMP	24" x 20"	6/4" to 57"	500	194	778.00
<b>ALUMINUM CONSTRUCTION</b>						
ALLW-2020-FW	WINCH	20" x 20"	3/4" to 58"	400	130	\$527.00
ALLW-2420-4SFL	WINCH	24" x 20"	6/4" to 59"	400	145	759.00
ALLH-2020-FW	FOOT PUMP	20" x 20"	3/4" to 53"	400	130	\$891.00
ALLH-2420-4SFL	FOOT PUMP	24" x 20"	6/4" to 57"	400	145	1,124.00

DC-25/FC-92.5

### LOW PROFILE LITE LOAD LIFTS

MODEL NUMBER	DESCRIPTION	PLATFORM SIZE (W x L)	SERVICE RANGE	CAPACITY (POUNDS)	NET WT. (POUNDS)	LIST PRICE EACH
<b>STEEL CONSTRUCTION</b>						
LLPW-500-FW	WINCH	20" x 20"	1/4" to 55"	500	176	\$437.00
LLPW-500-4SFL	WINCH	20" x 20"	1/4" to 58"	500	200	616.00
LLPH-500-FW	FOOT PUMP	20" x 20"	1/4" to 50"	500	180	\$609.00
LLPH-500-4SFL	FOOT PUMP	20" x 20"	1/4" to 50"	500	205	778.00
<b>ALUMINUM CONSTRUCTION</b>						
ALLPW-500-FW	WINCH	20" x 20"	1/4" to 55"	400	48	\$573.00
ALLPW-500-4SFL	WINCH	20" x 20"	1/4" to 58"	400	91	804.00
ALLPH-500-FW	FOOT PUMP	20" x 20"	1/4" to 50"	400	46	\$936.00
ALLPH-500-4SFL	FOOT PUMP	20" x 20"	1/4" to 50"	400	89	1,068.00

DC-25/FC-92.5

### LITE LOAD LIFT OPTIONS

MODEL NUMBER	DESCRIPTION	NET WT. (POUNDS)	LIST PRICE EACH
LLW-FL	FLOOR LOCK, HAND OPERATED	11	\$50.00
LLH-DSP	2 SPEED FOOT PUMP WITH FLOW CONTROL & PRESSURE RELIEF	---	183.00

DC-25/FC-70

### COUNTER-BALANCED LITE LOAD LIFT (STEEL) (Includes weight counter-balance)

MODEL NUMBER	DESCRIPTION	PLATFORM SIZE (W x L)	SERVICE RANGE	CAPACITY (POUNDS)	NET WT. (POUNDS)	LIST PRICE EACH
LLCB-202058	WINCH	20" x 20"	3 1/2" to 59"	300	475	\$589.00

CAPACITY OF 300 LBS. IS BASED ON A 10" HORIZONTAL LOAD CENTER

DC-25/FC-92.5

## Fully Portable Aluminum Load Lifter

Ideal for the traveling salesperson as well as service and installation crews. Weighs a modest 59 pounds, yet safely lifts and positions up to 220 pounds. Stores easily in a truck or a car. Rolls smoothly on 4" x 2 1/2" rear swivel casters and 3" x 1" front wheels. The overall size of the unit is 22 3/4" W x 30 3/4" L x 55" H.

MODEL NUMBER	PLATFORM SIZE (W x L)	SERVICE RANGE	LOAD CENTER	STRADDLE WIDTH	NET WT. (POUNDS)	LIST PRICE EACH
KLIFT-220	21 3/4" x 19 3/4"	6 1/2" to 47"	9 3/4"	21 1/2"	59	\$2,990.00

DC-20/FC-100+

## Hefti-Lifts

User-friendly portable hydraulic lifts provide reliable, powerful lifting when moving and positioning loads. Economical and attractive, they're ideal for commercial or industrial uses. Includes removable chrome platform for operations requiring forks. Manual hydraulic foot pump yields 3/4" of platform travel per stroke. Nonslip chain is used for accurate positioning. Units roll easily on two rigid and two swivel polyurethane casters and include a foot operated brake. Not for use with pallets. All welded steel construction with chrome platform and uprights. Each fork is 4 1/2"W x 2 1/2"H, the fork length is the same as the platform length. Overall fork width is 22".

MODEL NUMBER	PLATFORM SIZE (W x L)	SERVICE RANGE	CAPACITY (POUNDS)	OPERATION	NET WT. (POUNDS)	LIST PRICE EACH
HYD-5	23" x 24"	3 1/2" to 44"	880	FOOT PUMP	245	\$624.00
HYD-10	23" x 24"	3 1/2" to 59"	880	FOOT PUMP	275	717.00
HYD-15	23" x 31 1/2"	3 1/2" to 63"	1,500	FOOT PUMP	420	887.00
HYD-10-DC	23" x 24"	3 1/2" to 59"	880	12V DC POWER	440	2,397.00
<b>EXTENDED PLATFORM</b>						
HYD-5-EP	23" x 40"	3 1/2" to 44"	400	FOOT PUMP	276	\$702.00
HYD-10-EP	23" x 40"	3 1/2" to 59"	300	FOOT PUMP	320	800.00
<b>STAINLESS STEEL CONSTRUCTION</b>						
HYD-5-SS	23" x 24"	3 1/2" to 44"	880	FOOT PUMP	245	\$1,898.00
OPTIONAL HAND RELEASE, MODEL H-RELEASE, \$38.00 LIST					DC-25/FC-92.5	

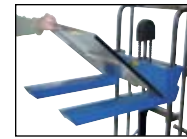

model HYD-5



model HYD-5-EP



DVD or VIDEO AVAILABLE



model HYD-10-DC

## Combination Hand Pump and Electric Stacker

An economical alternative DC powered lift stacker. Ideal for maintenance and commercial applications. 1500 watt motor, 40 amp battery and 10 amp charger. Individual forks are 6" wide.

MODEL NUMBER	OVERALL FORK SIZE (W x L)	LOWERED HEIGHT	RAISED HEIGHT	CAPACITY (POUNDS)	NET WT. (LBS.)	LIST PRICE EACH
SE/HP-63**	26 3/4" x 42"	3-11/32"	63"	2,000	750	\$1,654.00
SE/HP-98**	26 3/4" x 42"	3-11/32"	98"	2,000	850	2,048.00
SE/HP-118**	26 3/4" x 42"	3-11/32"	118"	2,000	990	2,258.00

DC-25/FC-92.5



SKID ONLY\*\*

series SE/HP



## Compact Powered Drive Lift

Counter balance design is ideal for die loading or machine feeding. Also ideal for loading and unloading trucks. Powered by a 700 watt driving motor and a 2000 watt lifting motor. 15 amp charger. Individual forks are 3-1/8" wide.

MODEL NUMBER	OVERALL FORK SIZE (W x L)	LOWERED HEIGHT	RAISED HEIGHT	CAPACITY (POUNDS)	NET WT. (POUNDS)	LIST PRICE EACH
S-CB-118	23-5/8" x 30"	1-3/16"	118"	1,000	1800	\$5,240.00

DC-25/FC-92.5



model S-CB-118



SKID\*\* & PALLETS



## Stacker with Powered Drive and Powered Lift

Transport loads throughout warehouse facilities quickly and with less effort. This powered drive stacker operates smoothly on concrete floors. Individual forks are 6" wide.

MODEL NUMBER	OVERALL FORK SIZE (W x L)	LOWERED HEIGHT	RAISED HEIGHT	CAPACITY (POUNDS)	NET WT. (POUNDS)	LIST PRICE EACH
<b>FIXED FORKS / ADJUSTABLE SUPPORT LEGS (works with pallets &amp; skids)</b>						
S-62-FA	26 3/4" x 42"	3-11/32"	62"	2,000	970	\$5,066.00
<b>ADJUSTABLE FORKS / ADJUSTABLE SUPPORT LEGS (works with pallets &amp; skids)</b>						
S-62-AA	26 3/4" x 42"	3-11/32"	62"	2,000	990	\$5,198.00
<b>FIXED FORKS OVER FIXED SUPPORT LEGS (works with skids only)</b>						
S-62-FF**	26 3/4" x 42"	3-11/32"	62"	2,000	950	\$4,804.00

DC-25/FC-92.5

model S-62-FF



model SL-63-FF



SKID\*\* & PALLETS



## Stacker with Powered Lift

Raise and lower loads quickly and easily with this highly efficient, durable lift. Manual push operation with powered lift. Powered with a 24V battery, includes charger. 135 amp battery.

MODEL NUMBER	OVERALL FORK SIZE (W x L)	LOWERED HEIGHT	RAISED HEIGHT	CAPACITY (POUNDS)	NET WT. (POUNDS)	LIST PRICE EACH
<b>ADJUSTABLE FORKS / ADJUSTABLE SUPPORT LEGS (works with pallets &amp; skids)</b>						
SL-63-AA	26 3/4" x 42"	3-11/32"	63"	2,000	870	\$2,310.00
SL-118-AA	26 3/4" x 42"	3-11/32"	118"	2,000	1070	2,783.00
SL-137-AA	26 3/4" x 42"	3-11/32"	137"	2,000	1140	3,045.00
<b>FIXED FORKS OVER FIXED SUPPORT LEGS (works with skids only)</b>						
SL-63-FF**	26 3/4" x 42"	3-11/32"	63"	2,000	830	\$2,048.00
SL-118-FF**	26 3/4" x 42"	3-11/32"	118"	2,000	1020	2,520.00

DC-25/FC-92.5





model HYDRA-4

model HYDRA-HD

model HYDRA-2

## Hydra Carts

Transport loads in the lowered position and maneuver work materials without the use of a fork truck. Safe and easy one person handling of loads up to 1,000 pounds. An efficient way to unload heavy objects from semi trailers. Rugged steel construction for years of service. Dependable precision built hydraulic system is activated by easy action foot lever. Steel construction.

MODEL NUMBER	PLATFORM SIZE (W x L)	SERVICE RANGE	CAPACITY (POUNDS)	NET WT. (POUNDS)	LIST PRICE EACH
HYDRA-2	20" x 16"	0 to 52"	750	240	\$568.00
HYDRA-4	20" x 22"	5½" to 52"	750	260	615.00
HYDRA-HD	24" x 22"	5½" to 55"	1,000	299	751.00

DC-25/FC-92.5+

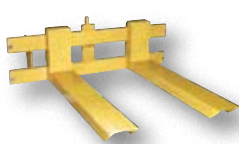

model HYDRA-AF-18  
O.D. of forks 6" to 22"



DVD or VIDEO AVAILABLE



model HYDRA-H  
Shown attached to HYDRA-HD



### HYDRA CART OPTIONS

MODEL NUMBER	DESCRIPTION	LIST PRICE EACH
HYDRA-AF-18	3" WIDE BY 18" LONG FORKS	\$304.00
HYDRA-H	HAND CRANK WINCH AND HOOK OPTION	183.00
HYDRA-FL	FLOOR LOCK	81.00



## Portable Hand Winch Lifter

This lift is easy to maneuver with its 4" x 1" wheels, two rigid, two locking swivel. Features a removable platform for increased versatility. Platform size is 20" wide by 20" long. The handle length on the hand crank may be adjusted to increase or decrease lifting/lowering speeds. Lifts 2½" per rotation. The forks measure 19¾" long. Capacity 330 pounds.

MODEL NUMBER	OVERALL SIZE (W x H)	SERVICE RANGE	OPERATION	NET WT. (POUNDS)	LIST PRICE EACH
HWL-330	20½" x 58"	3" TO 43½"	HAND WINCH	110	\$396.00

DC-25/FC-92.5

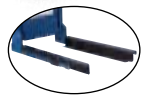

"L" shaped holding bracket

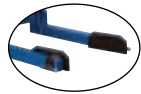

"T" shaped holding bracket



## Adjustable Box Stacker

The Adjustable Box Stacker is specially designed for transporting, stacking, and lifting plastic crates and similar types of containers. All models are compact and light weight. Both fork width and box clamps are adjustable to fit different size boxes and containers. All box clamps are rubber coated for extra grip. Capacity is 380 pounds.

MODEL NUMBER	FORK LENGTH	SERVICE RANGE	OPERATION	NET WT. (POUNDS)	LIST PRICE EACH
ABS-130	19½"	2¾" to 42¼"	FOOT PUMP	156	\$577.00

DC-25/FC-92.5

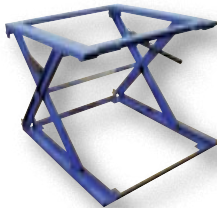

model PS-4045



DVD or VIDEO AVAILABLE



## Adjustable Pallet Stands

The Adjustable Height Pallet Stand is designed to manually adjust to three different ergonomic working heights. Unit includes a three position manual adjusting bar with spring assist to help raise and lower the deck. The Pallet Stand must be empty when adjusting the height. Unit is welded steel construction and painted blue. Optional bolt on manual carousel also available, PS-4045-CA. (Carousel is 40" diameter x 2" tall and rotates 360°)

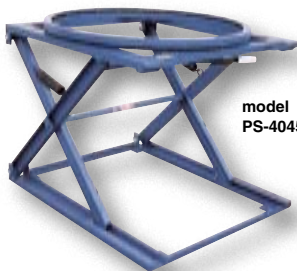

model PS-4045-CA

MODEL NUMBER	PLATFORM SIZE (W x L)	CAPACITY (POUNDS)	LOWERED HEIGHT	FIRST SETTING	SECOND SETTING	THIRD SETTING	NET WT. (LBS.)	LIST PRICE EACH
PS-4045	40" x 42"	5,000	10"	20¼"	30½"	35¼"	224	\$479.00
PS-4045-CA	40" x 42"	4,000	12¼"	22½"	32¾"	37½"	320	833.00
PS-CK+	*CASTER KIT 6" x 2" PHENOLIC (2) RIGID (2) SWIVEL W/BRAKE						35	\$104.00

\*FACTORY INSTALLED ONLY. CONTACT FACTORY FOR HEIGHT SETTINGS WITH CASTERS.  
+CAPACITY IS 1,500 LBS. / DO NOT MOVE WHEN LOADED.

DC-25/FC-70

## Self-Elevating Spring Tables

Self-Elevating Tables are designed to automatically raise or lower as materials are removed or added to the platform, keeping material at an ergonomic work height. These tables increase productivity while reducing potentially harmful bending and twisting motions. The counter balance springs can easily be added or removed to adjust weight-to-height sensitivity. This feature allows the user to conveniently set the table to fit each application. The ETS-230/460 has polyurethane casters while the ETS-840/1120 rolls smoothly on mold-on-rubber casters.

MODEL NUMBER	PLATFORM SIZE (W x L)	CAPACITY (POUNDS)	SERVICE RANGE	CASTER SIZE	OVERALL SIZE (W x L x H)	NET WT. (POUNDS)	LIST PRICE EACH
ETS-230	20" x 20"	230	11" to 33"	4" x 1 1/4"	21" x 28" x 37"	189	<b>\$911.00</b>
ETS-460	20" x 20"	460	11" to 33"	4" x 1 1/4"	21" x 28" x 37"	216	<b>1,024.00</b>
ETS-840-30	30" x 30"	840	15" to 38"	4" x 2"	31" x 38" x 52"	448	<b>1,639.00</b>
ETS-1120-18	18" x 18"	1,120	15" to 38"	4" x 2"	19" x 26" x 52"	380	<b>1,349.00</b>
ETS-1120-24	24" x 24"	1,120	15" to 38"	4" x 2"	25" x 32" x 52"	385	<b>1,411.00</b>

DC-30/FC-70

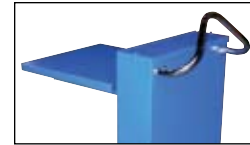

DVD or VIDEO AVAILABLE



Custom Finish Available

## Auto-Hite Carts

The Auto-Hite Cart raises or lowers as materials are removed or added to the platform, keeping material at an ergonomic work height. Increase efficiency while reducing potentially harmful bending and twisting motions. Carts utilize tension springs which can be adjusted in order to fit each particular application. All steel construction with removable handle. Polyurethane casters are 5" x 2", (2) rigid and (2) swivel with brake. Overall height is 38".

MODEL NUMBER	PLATFORM SIZE (W x L)	CAPACITY (POUNDS)	SERVICE RANGE	MOVEMENT* LBS. / INCH	OVERALL SIZE (W x L)	NET WT. (LBS.)	LIST PRICE EACH
SCSC-500-2040 <sup>Ⓢ</sup>	20" x 40"	500	14" to 34"	25# / 1"	20" x 45"	359	<b>\$920.00</b>
SCSC-500-4242	42" x 42"	500	14" to 34"	25# / 1"	42" x 45"	366	<b>1,142.00</b>
SCSC-1000-4242 <sup>Ⓢ</sup>	42" x 42"	1,000	14" to 34"	50# / 1"	42" x 45"	368	<b>1,271.00</b>
SCSC-1000-4848	48" x 48"	1,000	14" to 34"	50# / 1"	48" x 53"	419	<b>1,701.00</b>
SCSC-2000-4848	48" x 48"	2,000	14" to 34"	100# / 1"	48" x 53"	531	<b>2,176.00</b>

\*APPROXIMATE RATIO

DC-25/FC-70



model SCSC-500-4242



DVD or VIDEO AVAILABLE

## Self-Elevating Lift Carts

These carts raise and lower as materials are removed or added to the platform. Automatic height adjustment provides ergonomic work positioning to increase productivity and decrease work related repetitive motion injuries. Heavy-duty steel construction with removable bolt-on handle. 5" x 1" poly-on-steel, 2 rigid and 2 swivel casters with brake standard.

MODEL NUMBER	PLATFORM SIZE (W x L)	CAPACITY (POUNDS)	SERVICE RANGE	OVERALL SIZE (W x L x H)	NET WT. (POUNDS)	LIST PRICE EACH
SCSC-400-2032	20" x 32"	400	13 3/4" to 30"	20" x 40" x 30 1/2"	200	<b>\$475.00</b>
SCSC-800-2040	20" x 40"	800	14 1/2" to 31"	20" x 48" x 35 1/2"	300	<b>560.00</b>

DC-25/FC-100



## Long Deck Carts

The Long Deck Cart is perfect for sheet and strip handling, ergonomic load positioning, and handling long awkward material loads. Platform height is adjusted with manual hydraulic foot pump. Structural steel base helps to distribute the load evenly. Unit comes standard with (4) swivel 5" x 2" polyurethane casters and dual floor locks. (1/4" thick deck)

MODEL NUMBER	PLATFORM SIZE (W x L)	CAPACITY (POUNDS)	RAISED HEIGHT	LOWERED HEIGHT	NET WT. (POUNDS)	LIST PRICE EACH
LDLT-3060	30" x 60"	2,000	48"	31"	518	<b>\$1,245.00</b>
LDLT-3072	30" x 72"	2,000	48"	31"	563	<b>1,272.00</b>
LDLT-3096	30" x 96"	2,000	48"	31"	638	<b>1,591.00</b>
LDLT-30120	30" x 120"	2,000	48"	31"	771	<b>1,628.00</b>

AC POWER 115, 208-230, 460V - 1 OR 3 PHASE, MODEL LDLT-AC, \$695.00 LIST

DC-20/FC-70

DC POWER 12V (BATTERY CHARGER INCLUDED), MODEL LDLT-DC, \$695.00 LIST

RECIPROCATING AIR/OIL POWER WITH FOOT TREADLE CONTROL, MODEL LDLT-AIR, \$419.00 LIST

DC POWER WITH BATTERY, MODEL LDLT-DC  
FACTORY AIR/OIL, MODEL LDLT-AIR

## Hydraulic Post Tables



Foot-operated hydraulic post lift tables are built for heavy-duty shop use such as lifting dies and castings, moving machine parts, positioning welders' work, leveling feed material for pump presses, conveyors and press brakes, and similar material handling jobs. Posts are telescoping to help stabilize and support loads during operation. Light-duty units feature a single-speed foot pump. Heavy-duty units feature a two-speed foot pump for maximum operator convenience. All foot pumps include a down speed control valve for safe platform lowering.

DC units include a 12V DC electric motor to raise and lower the platform. They also include a battery, on-board charger, and a hand control on an 8 ft. coil cord.

Units include four casters; two swivel with total-locking brakes and two rigid.

Model HT-02-1616A includes a platform that swivels 360° for use as a turntable. Model HT-02-1616A and HT-05-1818A come with a removable rubber platform cover.

MODEL NUMBER	PLATFORM SIZE (W x L)	CAPACITY (POUNDS)	SERVICE RANGE	NUMBER OF POSTS	CASTER SIZE/TYPE	OPERATION	NET WT. (LBS.)	LIST PRICE EACH
HT-02-1616A	16" x 16"	200	49" to 31"	1	4" x 1 1/4" POLY	1-SPEED FOOT PUMP	120	\$274.00
HT-03-1616	16" x 16"	300	49" to 31"	1	4" x 1 1/4" POLY	1-SPEED FOOT PUMP	120	384.00
HT-05-1818A	18" x 18"	500	49" to 31"	2	4" x 1 1/4" POLY	1-SPEED FOOT PUMP	125	418.00
HT-10-2036A	20" x 36"	1,000	54" to 36"	2	4" x 2" PHENOLIC	2-SPEED FOOT PUMP	275	538.00
HT-20-2436A	24" x 36"	2,000	54" to 36"	4	4" x 2" PHENOLIC	2-SPEED FOOT PUMP	323	\$762.00
HT-20-3036A	30" x 36"	2,000	54" to 36"	4	4" x 2" PHENOLIC	2-SPEED FOOT PUMP	400	801.00
HT-20-3042	30" x 42"	2,000	54" to 36"	4	4" x 2" PHENOLIC	2-SPEED FOOT PUMP	450	820.00
HT-20-3248	32" x 48"	2,000	54" to 36"	4	4" x 2" PHENOLIC	2-SPEED FOOT PUMP	475	874.00
HT-30-2436	24" x 36"	3,000	54" to 36"	4	4" x 2" PHENOLIC	2-SPEED FOOT PUMP	330	\$774.00
HT-30-3036	30" x 36"	3,000	54" to 36"	4	4" x 2" PHENOLIC	2-SPEED FOOT PUMP	485	813.00
HT-30-3042	30" x 42"	3,000	54" to 36"	4	4" x 2" PHENOLIC	2-SPEED FOOT PUMP	470	823.00
HT-40-2436	24" x 36"	4,000	54" to 36"	4	4" x 2" PHENOLIC	2-SPEED FOOT PUMP	441	\$835.00
HT-40-3036	30" x 36"	4,000	54" to 36"	4	4" x 2" PHENOLIC	2-SPEED FOOT PUMP	462	873.00
HT-40-3042	30" x 42"	4,000	54" to 36"	4	4" x 2" PHENOLIC	2-SPEED FOOT PUMP	475	884.00
HT-60-2436	24" x 36"	6,000	54" to 36"	4	6" x 2 1/2" PHENOLIC	2-SPEED FOOT PUMP	577	\$906.00
HT-60-3248	32" x 48"	6,000	54" to 36"	4	6" x 2 1/2" PHENOLIC	2-SPEED FOOT PUMP	594	1,000.00
HT-20-2436-DC	24" x 36"	2,000	54" to 36"	4	4" x 2" PHENOLIC	12V DC POWER	390	\$1,509.00
HT-20-3036-DC	30" x 36"	2,000	54" to 36"	4	4" x 2" PHENOLIC	12V DC POWER	482	1,542.00

LOW PROFILE & SHORT PUMP LIFT RANGE AVAILABLE. CONSULT FACTORY. AC, DC, LINEAR ACTUATED or AIR/OIL AVAILABLE. MODEL NUMBERS WITH THE SUFFIX "A" ARE SHIPPED KNOCK-DOWN

DC-20/FC-70

## Mechanical Post Tables

Adjustable height portable tables are well suited for a wide variety of material handling applications. Moves smoothly on two rigid and two swivel 5" x 2" polyurethane casters. All welded steel construction (1/4" deck) and blue powder coat top. Provide positive height adjustment without downward drift. Features a two-speed manual gear mechanism to move heavy loads at 1/8" per crank rotation or lighter loads at 5/16" per crank rotation. DC powered unit includes an on-board charger.



model MT-2436-LP

**LINE-X**  
Custom Finish Available



model MT-2436-LP-DC

MODEL NUMBER	PLATFORM SIZE (W x L)	CAPACITY (POUNDS)	RAISED HEIGHT	LOWERED HEIGHT	OPERATION	NET WT. (POUNDS)	LIST PRICE EACH
MT-2436-LP	24" x 36"	2,000	42"	24"	LOW PROFILE	330	\$784.00
MT-2442-LP	24" x 42"	2,000	42"	24"	LOW PROFILE	380	1,151.00
MT-3042-LP	30" x 42"	2,000	42"	24"	LOW PROFILE	425	1,250.00
MT-3048-LP	30" x 48"	2,000	42"	24"	LOW PROFILE	475	1,432.00
MT-2436-HP	24" x 36"	2,000	46"	28"	HIGH PROFILE	375	\$800.00
MT-2442-HP	24" x 42"	2,000	46"	28"	HIGH PROFILE	415	1,186.00
MT-3042-HP	30" x 42"	2,000	46"	28"	HIGH PROFILE	450	1,291.00
MT-3048-HP	30" x 48"	2,000	46"	28"	HIGH PROFILE	490	1,479.00
MT-2436-LP-DC	24" x 36"	2,000	42"	24"	DC BATTERY	430	\$2,714.00
MT-2436-LP-AC	24" x 36"	2,000	42"	24"	AC POWER	430	2,714.00

DC-20/FC-70



## Post Lift Tables

Low profile foot pump hydraulic post lift tables utilize either a formed base or a telescoping cylinder to achieve a more versatile lifting range.

MODEL NUMBER	PLATFORM SIZE (W x L)	CAPACITY (POUNDS)	SERVICE RANGE	NET WT. (POUNDS)	LIST PRICE EACH
PTS-20-2436	24" x 36"	2,000	21¼" to 49¼"	330	\$1,061.00
PTS-20-3042	30" x 36"	1,000	26½" to 59"	400	1,217.00
PT12-10	20" x 30"	2,000	25" to 37"	175	435.00
PT12-20	24" x 36"	2,000	25" to 37"	220	517.00
PT12-40	24" x 36"	4,000	25" to 37"	270	607.00
PT2436E*	24" x 36"	2,000	34" to 52"	240	1,132.00

\*LINEAR ACTUATED POWER

DC-20/FC-70



PTS-20-2436



PTS-20-3042



PT12-10



PT2436E

## Air Hydraulic Carts



Features two speed foot pump and a hand held reciprocating air/oil power to raise the platform. Utilize the two speed foot pump for minor height adjustments and the factory air/oil power for effortless lifting of up to 2,000 pounds.

MODEL NUMBER	PLATFORM SIZE (W x L)	CAPACITY (POUNDS)	SERVICE RANGE	CASTER SIZE	NET WT. (POUNDS)	LIST PRICE EACH
AIR-800-D	20" x 35½"	800	13¾" to 51"	5" x 1½"	285	\$695.00
AIR-1000	19¾" x 32½"	1,000	15¾" to 35½"	5" x 1½"	190	570.00
AIR-1000-LD	31½" x 63"	1,000	15½" to 35½"	5" x 1½"	340	896.00
AIR-1500-D	19½" x 67"	1,500	19½" x 67"	6" x 2"	550	1,056.00
AIR-1750	20" x 39½"	1,750	14¼" to 39½"	6" x 2"	265	698.00
AIR-2000	24" x 47¼"	2,000	15" to 39½"	6" x 2"	385	780.00

DC-20/FC-70



## Pneumatic Scissor Lift Table

This unit works great in many clean room applications. This unit can be used anywhere utilizing only shop air. Air actuator valve included. No electrical power required.



MODEL NUMBER	PLATFORM SIZE (W x L)	CAPACITY (POUNDS)	SERVICE RANGE	NET WT. (POUNDS)	LIST PRICE EACH
AT-10	19½" x 39½"	200	11¼" to 29½"	205	\$590.00

DC-20/FC-70

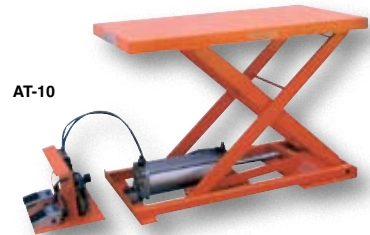

AT-10

## Mechanical Scissor Cart

Raise and lower material quickly and easily with our Mechanical Scissor Cart. Cart rolls smoothly on two rigid and two swivel casters. Mechanical screw drive provides precise positioning with no downward drift.



MODEL NUMBER	PLATFORM SIZE (W x L)	CAPACITY (POUNDS)	LOWERED HEIGHT	RAISED HEIGHT	NET WT. (POUNDS)	LIST PRICE EACH
CART-660-M	23½" x 37"	660	17¼"	39¼"	143	\$303.00

DC-20/FC-70



CART-660-M

## Scissor Cart Scale

Ideal for parts counting, inventory rooms, or shipping weights at the loading dock. Provides an ergonomic workstation while sitting or standing.



MODEL NUMBER	PLATFORM SIZE (W x L)	CAPACITY (POUNDS)	LOWERED HEIGHT	RAISED HEIGHT	NET WT. (POUNDS)	LIST PRICE EACH
CART-500-SCL	19½" x 32"	500	14"	38"	215	\$865.00

INCLUDES A BUILT-IN SCALE

DC-20/FC-70



CART-500-SCL

## Combination Hydraulic Elevating Carts

Portable combination ergonomic elevating carts minimize worker bending and lifting. Units include a combination foot pump and air oil power unit increasing its versatility. Carts move easily on four polyurethane casters, two swivel with brakes and two rigid. All models feature an internal hydraulic velocity fuse in each cylinder.



MODEL NUMBER	PLATFORM SIZE (W x L)	CAPACITY (POUNDS)	LOWERED HEIGHT	RAISED HEIGHT	NET WT. (POUNDS)	LIST PRICE EACH
CART-750-CMB	19¾" x 32½"	750	15½"	35½"	260	\$609.00
CART-1000-CMB	19¾" x 32"	1,000	15½"	35½"	265	660.00
CART-1000-LD-CMB	31½" x 63"	1,000	15"	36"	345	725.00

DC-25/FC-70



CART-1000-CMB

## Hydraulic Elevating Carts

Portable ergonomic elevating carts minimize worker bending and lifting. Material can be easily loaded onto cart from table, lowered to safe transporting height, and raised to unload at destination. Foot pump includes a soft-lowering down valve. Move easily on four polyurethane casters, two swivel with brakes, and two rigid. All models feature an internal hydraulic velocity fuse in each cylinder. Steel or stainless steel construction.



DVD or VIDEO AVAILABLE on CART-1500-D-TS

48 Hours to Ship

MODEL NUMBER	DESCRIPTION	PLATFORM SIZE (W x L)	CAPACITY (POUNDS)	SERVICE RANGE	FOOT PUMP SPEED	NET WT. (POUNDS)	LIST PRICE EACH	PRICE FOR 2 OR MORE
CART-200	DOUBLE SCISSOR	17½" x 27½"	220	13" to 50"	SINGLE	140	\$393.00	\$335.00
CART-400	SINGLE SCISSOR	17½" x 27½"	400	8¾" to 29"	SINGLE	108	347.00	295.00
CART-750-TS	SINGLE SCISSOR	19¾" x 32½"	750	15½" to 35½"	TWO	255	575.00	490.00
CART-800-D-TS	DOUBLE SCISSOR	20" x 35½"	800	15½" to 50¾"	TWO	330	755.00	640.00
CART-1000-TS	SINGLE SCISSOR	19¾" x 32"	1,000	15½" to 35½"	TWO	260	\$625.00	\$530.00
CART-1000-LD	SINGLE SCISSOR	31½" x 63"	1,000	15" to 36"	TWO	340	709.00	603.00
CART-1500-D-TS	DOUBLE SCISSOR	24" x 47½"	1,500	19" to 68"	TWO	552	1,112.00	946.00
CART-1750	SINGLE SCISSOR	20" x 39½"	1,750	16" to 39"	SINGLE	288	1,004.00	845.00
CART-DS-1000-M	DOUBLE SCISSOR	20" x 33"	1,000	14" to 40"	TWO	355	\$1,437.00	\$1,365.00
CART-2000-WD	SINGLE SCISSOR	32" x 40"	2,000	15" to 39"	TWO	285	1,684.00	1,602.00
CART-2000	SINGLE SCISSOR	20" x 40"	2,000	15" to 39"	TWO	350	1,360.00	1,295.00
CART-4000	SINGLE SCISSOR	24" x 47"	4,000	15½" to 40"	TWO	595	1,481.00	1,344.00
CART-200-PSS	STAINLESS STEEL	17½" x 27½"	220	13" to 50"	SINGLE	128	\$736.00	\$611.00
CART-550-SS	STAINLESS STEEL	19½" x 31½"	550	9¾" to 33½"	TWO	160	4,291.00	4,260.00
CART-1000-PSS	STAINLESS STEEL	19" x 32"	1,000	15" to 35½"	SINGLE	299	1,097.00	932.00
CART-1100-SS	STAINLESS STEEL	23½" x 35½"	1,100	13" to 38½"	TWO	240	4,884.00	4,859.00

MODEL NUMBER	OPTIONS FOR CART-2000, CART-2000-WD AND CART-DS-1000-M ONLY	NET WT. (LBS.)	LIST PRICE EACH
CART-FC	FOOT TREADLE AIR/HYDRAULIC OIL OPTION	24	\$407.00
CART-AC	24V HAND HELD CONTROL, 115V AC POWER	48	680.00
CART-DC	HAND HELD CONTROL, 12V DC POWER OPTION WITH BATTERY	60	680.00
CART-BC	EXTERNAL BENCH TOP STYLE BATTERY CHARGER	8	122.50
CART-OB	ON BOARD STYLE BATTERY CHARGER	10	195.00
CART-BCI	BATTERY CHARGE INDICATOR GAUGE	1	75.00
CART-TD	TRACTION DRIVE OPTION (TWIST THROTTLE DESIGN), 24V DC (CART NOT INCLUDED)	156	2,365.00

\*THE SCISSOR LEGS & PUMP ASSEMBLY ARE CHROME PLATED ON THE STAINLESS STEEL CARTS

DC-20\*\*/25/FC-70



## DC Powered Hydraulic Elevating Carts

These carts are ideal for quick lifting and ergonomic material handling. Battery-powered unit allows operators to raise and lower platform with the push of a button. Unit rolls on two rigid and two swivel polyurethane casters. Includes battery and on-board battery charger.

MODEL NUMBER	DESCRIPTION	PLATFORM SIZE (W x L)	CAPACITY (POUNDS)	SERVICE RANGE	NET WT. (POUNDS)	LIST PRICE EACH
CART-1000D-DC	DOUBLE SCISSOR	20½" x 39¾"	1,000	19½" to 63¾"	484	\$1,437.00
CART-1000-DC	SINGLE SCISSOR	20½" x 39¾"	1,000	17½" to 37½"	419	1,365.00
CART-1000-LD-DC	SINGLE SCISSOR	24½" x 60"	1,000	17½" to 45"	473	1,839.00
CART-2000-DC	SINGLE SCISSOR	20" x 40"	2,000	15" to 39"	360	1,993.00
CART-DS-1000	DOUBLE SCISSOR	20" x 33"	1,000	14" to 40"	370	2,029.00
CART-SCTAB-500-DC	SINGLE SCISSOR	20" x 33"	500	13" to 35"	366	\$1,473.00
CART-SCTAB-750D-DC	DOUBLE SCISSOR	20" x 40"	750	14" to 42"	387	1,720.00
CART-SCTAB-1000-DC	SINGLE SCISSOR	20" x 40"	1,000	14" to 38"	402	1,658.00
CART-SCTAB-2000-DC	SINGLE SCISSOR	42" x 42"	2,000	15" to 39"	514	2,137.00

DC-20/FC-70



## DC Powered and Manual Scissor Carts

Tables provide unparalleled ergonomic support in lifting, palletizing, loading, and unloading applications. Carts are raised or lowered with either a 12V DC powered motor or a manual two-speed foot pump. Units roll smoothly with (2) rigid and (2) swivel 4" x 2" phenolic casters with brakes. Push handle is removable.

Internal DC powered electric motor and 12V battery is included on DC units. Electric motor is rated at 1600 watts. Built-in battery charger is included (operated on 115V AC power). Push buttons to raise and lower lift are located on the power unit. Hand control on coil cord is also standard. Key-operated ON/OFF control for better security is built into the power unit. Platform is equipped with perimeter pinch-point guard for OSHA compliance.

MODEL NUMBER	PLATFORM SIZE (W x L)	SERVICE RANGE	CAPACITY (POUNDS)	LIFT SPEED OR # OF PUMPS	NET WT. (POUNDS)	LIST PRICE EACH
<b>12V DC POWER</b>						
<b>CART-23-10-DC</b>	24" x 36"	11¼" to 32"	1,000	14 sec.	410	<b>\$1,654.00</b>
<b>CART-23-15-DC</b>	24" x 36"	11¼" to 32"	1,500	16 sec.	450	<b>1,759.00</b>
<b>CART-24-10-DC</b>	24" x 48"	9¼" to 42½"	1,000	15 sec.	460	<b>1,748.00</b>
<b>CART-24-15-DC</b>	24" x 48"	9¼" to 42½"	1,500	17 sec.	500	<b>1,848.00</b>
<b>TWO-SPEED FOOT PUMP</b>						
<b>CART-23-10-M</b>	24" x 36"	11¼" to 32"	1,000	54 low - 27 high	380	<b>\$1,129.00</b>
<b>CART-23-15-M</b>	24" x 36"	11¼" to 32"	1,500	54 low - 27 high	420	<b>1,223.00</b>
<b>CART-24-10-M</b>	24" x 48"	9¼" to 42½"	1,000	63 low - 31 high	430	<b>1,234.00</b>
<b>CART-24-15-M</b>	24" x 48"	9¼" to 42½"	1,500	63 low - 31 high	470	<b>1,323.00</b>

DC-20/FC-70



DVD or VIDEO AVAILABLE



MANUAL TWO-SPEED FOOT PUMP



Custom Finish Available



12V DC POWER

## Die Table

Designed to reduce back injury and cumulative trauma disorders. Lifts heavy equipment to dynamic working height. Manually operated hydraulic foot pump and lift cylinder. Handle height is 41". All welded steel construction will provide years of service and hard work. Small frame size allows unit to access hard-to-reach locations. Two rigid and two swivel casters with a floor lock.

MODEL NUMBER	PLATFORM SIZE (W x L)	CAPACITY (POUNDS)	LOWERED HEIGHT	RAISED HEIGHT	NET WT. (POUNDS)	LIST PRICE EACH
<b>DIE-2430</b>	24" x 30"	2,000	29"	44"	322	<b>\$536.00</b>

DC-20/FC-70



## Lift & Tilt Carts with Sequence Select

*Model CART-1100-LT* has a unique design which allows the user to RAISE and TILT materials to an ergonomic position for better posture and operator comfort. The manual hydraulic foot pump controls the platform lift, lower, and tilt. A manual selector valve is used to control the lift/lower sequence independently from the tilt sequence. The service range in the tilt position is 34¼" to 54¼". The hinged platform includes a 7" high retaining lip. Cart is portable with two rigid and two swivel 5" casters.

*Model CART-400-LT and CART-600-LT* are elevated by means of a foot actuated hydraulic cylinder. As the table is raised, it simultaneously tilts to an angle of 45° at full elevation. Built-in retaining lip keeps containers in place.

MODEL NUMBER	PLATFORM SIZE (W x L)	CAPACITY (POUNDS)	MAXIMUM TILT	*SERVICE RANGE	NET WT. (POUNDS)	LIST PRICE EACH
<b>CART-1100-LT</b>	22" x 33½"	1,100	35°	17-5/8" to 34¼"	320	<b>\$778.00</b>
<b>CART-400-LT</b>	19½" x 30"	400	45°	13" to 31"	200	<b>\$598.00</b>
<b>CART-600-LT</b>	24" x 36"	600	45°	14" to 35"	300	<b>660.00</b>

\*SERVICE RANGE FIGURED WITH PLATFORM LEVEL

DC-25/FC-70

model CART-400-LT  
CART-600-LT

## Traction Drive Electric Hydraulic Elevating Carts

The Traction Drive Electric Hydraulic Elevating Cart makes maneuvering heavy loads virtually effortless. A twist style throttle with reverse facilitates the maneuverability of this cart. The push of a button will raise and lower the platform. 24V DC battery operated with an on-board battery charger and maintenance free batteries. Standard features include: powered front drive wheels, twist style throttle with reverse, and fully programmable motor controller.

MODEL NUMBER	PLATFORM SIZE (W x L)	CAPACITY (POUNDS)	SERVICE RANGE	NET WT. (POUNDS)	LIST PRICE EACH
<b>CART-DS-1000-CTD</b>	20" x 33"	1,000	15" to 41"	452	<b>\$3,498.00</b>
<b>CART-2000-CTD</b>	20" x 40"	2,000	16" to 40"	513	<b>3,596.00</b>
<b>CART-BCI</b>	BATTERY CHARGE INDICATOR GAUGE			1	<b>\$75.00</b>

DC-20/FC-70



TWIST STYLE THROTTLE



DVD or VIDEO AVAILABLE

model  
CART-DS-1000-CTD





### Linear Actuated Elevating Cart

Transport materials from workstation to workstation with ease. Platform is raised and lowered with an electric linear actuator for precise positioning. Linear actuator will not allow platform to drift down - a common problem with hydraulic carts. This linear actuated cart is powered with a 12 volt DC battery and features an on-board charger. Hand held pendant control connects to power unit with a 6 foot coil cord. Emergency stop button standard on hand control. Includes two rigid and two swivel casters.

MODEL NUMBER	PLATFORM SIZE (W x L)	CAPACITY (POUNDS)	LOWERED HEIGHT	RAISED HEIGHT	NET WT. (POUNDS)	LIST PRICE EACH
<b>CART-500-LA</b>	19½" x 32"	500	14"	35"	330	<b>\$840.00</b>

DC-25/FC-70



Cart Sold Separately. See Page 60

### Conveyor with Retractable End Stops

Provide smooth and easy flow from cart to workstation. Attaches to any scissor table, cart or work bench with a deck length of 32". Allows you to position objects easily. Features retractable end stops so items won't slide off during transit. Ideal for use at feed tables for sheet metal working machines, press brakes, and machine centers. Adds 3¾" to lowered and raised height of cart.



Retractable End Stop

MODEL NUMBER	PLATFORM SIZE (W x L x H)	CAPACITY (POUNDS)	ROLLER SPACING	NET WT. (POUNDS)	LIST PRICE EACH
<b>CONV-1832</b>	18" x 32" x 3¾"	800	3" CENTERS	63	<b>\$192.00</b>

DC-25/UPS/FC-100



Shown with a Hydraulic Scissor Cart (Cart Sold Separately)

### Ball Transfer Platforms

Units simply bolt on to any platform. Chrome ball transfers are on 4" centers with a square pattern while the powder coated units are on 3" centers. All units have 12 gauge chrome base. Attach to Hydraulic and Mechanical Post Tables and Lift Tables. Optional 18"W x 2"H retractable stops available.

MODEL NUMBER	OVERALL SIZE (W x L)	CAPACITY PER BALL (POUND)	FINISH	NET WT. (POUNDS)	LIST PRICE EACH
<b>BALL-1830</b>	18" x 28"	75	CHROME	30/UPS	<b>\$225.00</b>
<b>BALL-2036</b>	20" x 36"	75	CHROME	50/UPS	<b>277.00</b>
<b>BALL-2448</b>	24" x 48"	75	POWDER COAT BLUE	110/UPS	<b>338.00</b>
<b>BALL-4048</b>	40" x 48"	75	POWDER COAT BLUE	150	<b>449.00</b>
<b>BALL-3060</b>	30" x 60"	75	POWDER COAT BLUE	160	<b>470.00</b>

RETRACTABLE STOPS AT EACH END, MODEL BALL-RS, \$58.00 LIST (FACTORY INSTALLED)

DC-25/UPS/FC-85



Cart Sold Separately. See Page 60

### "Pop-Up" Ball Transfer Platforms

Minimize lifting and pushing with multi-directional Ball Transfer Platforms. An economical way to change direction for free movement of boxes, dies, and parts. A ball retraction handle is conveniently located on the side of the platform. Mount to our scissor carts or post tables. Rigid and retractable stops are available - contact factory.

MODEL NUMBER	OVERALL SIZE (W x L)	BALL SPACING (W x L)	CAPACITY (POUNDS)	NET WT. (POUNDS)	LIST PRICE EACH
<b>POPUP-1932</b>	19" x 32"	4½" x 5¼"	250	70	<b>\$237.00</b>
<b>POPUP-4048</b>	40" x 48"	4½" x 5¼"	250	180	<b>420.00</b>

DC-25/FC-85



BALL TRANSFER STRIP

### Ball Transfer Strips & Single Ball Transfers

Single strips of ball transfers are easy to install and simple to use. To install, simply line it up on your cart, table, or workstation and bolt on at each end. Standard finish is chrome.

The Single Ball Transfers feature a hardened cup, protective debris shield and include lag-down tabs.

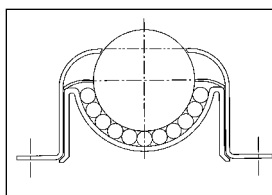

SINGLE BALL TRANSFER model BALL-1F

BALL TRANSFER STRIPS						
MODEL NUMBER	LENGTH	BALL SPACING	FINISH	CAPACITY PER BALL (POUNDS)	NET WT. (POUNDS)	LIST PRICE EACH
<b>BALL-S30</b>	30"	3¼"	CHROME	75	9	<b>\$49.00</b>
<b>BALL-S40</b>	40"	3¼"	CHROME	75	12	<b>64.00</b>
<b>BALL-S60</b>	60"	3¼"	CHROME	75	16	<b>81.00</b>
SINGLE BALL TRANSFER						
MODEL NUMBER	BALL DIAMETER	HEIGHT	FINISH	CAPACITY (POUNDS)	NET WT. (POUNDS)	LIST PRICE EACH
<b>BALL-1F</b>	1"	1/8"	ZINC PLATED	75	1/2	<b>\$2.30</b>

DC-25/UPS/FC-85

## Full Featured Pallet Trucks

• Heavy-duty 5,500 lbs. Capacity • Powder Coat Finish • User friendly entry and exit rollers  
 An economical way for one person to move heavy pallet loads without the use of a fork truck! Includes two articulating steering wheels and two front load rollers. Ergonomic design requires only 75 pounds of pulling force when fully loaded. Steering wheels include bearing dust covers for added life. Nose wheels are located on the front edge of each fork to assist in clean pallet entrance and exit. Reinforced triple-formed steel forks provide twice the strength of standard single-formed forks. Forks are 6¾" wide each. Equipped with internally mounted solid steel adjustable push rods. Spring loaded handle automatically returns to vertical position when not in use. Hydraulic pump design facilitates easy-access seal replacement. Chrome-plated hydraulic pump piston for long seal life. Also available in various sizes, capacities, and configurations as noted.

MODEL NUMBER	CAPACITY (POUNDS)	OVERALL FORK DIMENSIONS	FORK SERVICE RANGE	NET WT. (LBS.)	LIST PRICE EACH	LOTS OF 6 PRICE EACH †
PM5-2748Ⓢ	5,500	27"W x 48"L	2-7/8" to 7-3/4"	280	\$325.00	\$296.00
PM5-2048Ⓢ	5,500	20-5/8"W x 48"L	2-7/8" to 7-3/4"	225	325.00	296.00
PM5-2036	5,500	20"W x 36"L	2-7/8" to 7-3/4"	200	395.00	360.00
PM6-2748	6,000	27"W x 48"L	2-7/8" to 7-3/4"	330	\$445.00	\$390.00
PM10-2245	10,000	22¾"W x 45¼"L	3-1/2" to 7-7/8"	423	1,395.00	1,345.00
PM5-2748-N*	5,500	27"W x 48"L	2-7/8" to 7-3/4"	316	370.00	335.00
PM5-2748-S**	5,500	27"W x 48"L	2-7/8" to 7-3/4"	325	375.00	340.00
PM4-2772	4,400	27"W x 72"L	2-7/8" to 7-3/4"	401	567.00	521.00
PM4-2796	4,000	27"W x 96"L	2-7/8" to 7-3/4"	400	585.00	534.00

\*NYLON WHEELS / \*\*STEEL WHEELS (ALL OTHERS ARE POLY-ON-STEEL) †SHIPPED CRATED WITHOUT HANDLE ATTACHED DC-25/FC-70/92.5/175♦

OPTIONS FOR PM5-2748 ONLY (factory installed)		
PM5-HB	HAND BRAKE (DEPRESS HAND BRAKE TO SLOW DOWN/STOP)	\$46.00
PM5-DMHB	"DEAD MAN" HAND BRAKE (DEPRESS HAND BRAKE TO MOVE)	141.00
PM5-FB	FOOT BRAKE KIT (WORKS WITH PM4 & PM5 UNITS)	26.00

DC-25

## Standard Pallet Truck

• Economical • Powder Coat Finish • Quality Built • User Friendly • Low Maintenance  
 Proven ergonomic design has been time-tested for providing years of reliable service. An economical way for one person to move heavy pallet loads without the use of a fork truck. Ergonomic design requires only 75 pounds of pulling force when fully loaded. Spring loaded loop handle automatically returns to vertical position when not in use. Chrome-plated hydraulic pump piston for long seal life.

MODEL NUMBER	CAPACITY (POUNDS)	OVERALL FORK DIMENSIONS	FORK SERVICE RANGE	NET WT. (POUNDS)	LIST PRICE EACH	LOTS OF 6 PRICE EACH †
PM5-2748-Y	5,500	27"W x 48"L	2-7/8" to 7-3/4"	300	\$325.00	\$305.00

†SHIPPED CRATED WITHOUT HANDLE ATTACHED DC-25/FC-70/92.5/175♦

## Pallet Truck Caddy **New**

This economical product will convert a standard pallet truck into a portable workstation in minutes. It has been designed with user efficiency and convenience in mind. Easily attaches to virtually any type of pallet truck with hardware included. Manufactured from durable molded yellow plastic for an attractive look. Features beverage holder, tool pockets, pen and pencil tray, and clipboard holder. Large storage compartment in back can also be used as a wastebasket. Installation hardware and instructions included. Pallet Truck sold separately.

MODEL NUMBER	DESCRIPTION	NET WT. (POUNDS)	LIST PRICE EACH
P-CADDY	PALLET TRUCK CADDY	5	\$79.00

DC-25/UPS/FC-70

## Super Low Profile Pallet Trucks

These pallet trucks are ideal for extra low applications. Features 1½" lowered fork height for extra low profile skids, pallets, or machinery. Fingertip lever switch for raise, lower, and neutral operation. Rubber cushioned handle grip. Powder coat finish.

MODEL NUMBER	CAPACITY (POUNDS)	OVERALL FORK DIMENSIONS	FORK SERVICE RANGE	NET WT. (POUNDS)	LIST PRICE EACH
PM2-2044-SLP	2,200	20"W x 44"L	1-1/2" to 3-3/8"	313	\$439.00
PM2-2744-SLP	2,200	27"W x 44"L	1-1/2" to 3-3/8"	323	469.00
PM2-3344-SLP	2,200	33"W x 44"L	1-1/2" to 3-3/8"	333	480.00

DC-25/FC-70/92.5/175♦

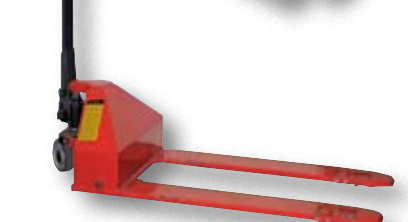
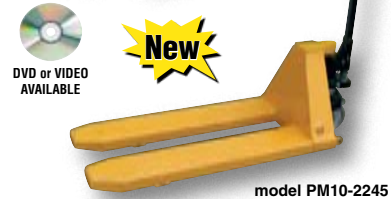
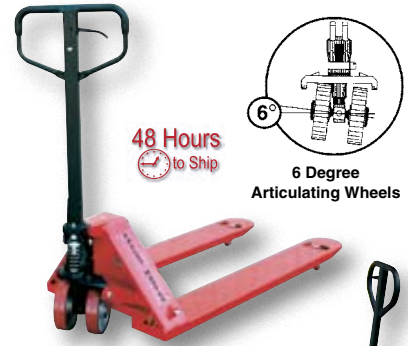



Low Profile Design with  
1-7/8" Lowered Height

48 Hours  
to Ship



DVD or VIDEO  
AVAILABLE

SCALE HEAD  
SHOWN WITH PRINTER  
model PM-2748-SCL-LP-PT

## Low Profile Pallet Trucks

The Low Profile Pallet Truck can enter a pallet from all four sides. All steel frame is reinforced to handle 4,000 lb. capacity loads. Individual fork width is 6¾" wide. Wide loop control handle with lift, neutral, and lower functions provides fingertip control. Lifetime lubricated bearings. Hydraulic system has hard chrome plated pump piston with polyurethane seals. Suspension system has heavy-duty thrust bearing. Complete with adjustable push rods, polyurethane wheels, steel load rollers, and red powder coat finish.

MODEL NUMBER	CAPACITY (POUNDS)	OVERALL FORK DIMENSIONS	FORK SERVICE RANGE	NET WT. (POUNDS)	LIST PRICE EACH	LOTS OF 6 PRICE EACH †
PM4-2048-LP <sup>⊕</sup> *	4,000	20-5/8"W x 48"L	1-7/8" to 6"	228	<b>\$348.00</b>	<b>\$310.00</b>
PM4-2748-LP <sup>⊕</sup>	4,000	27"W x 48"L	1-7/8" to 6"	270	<b>348.00</b>	<b>310.00</b>
PM4-3348-LP <sup>⊕</sup>	4,000	33"W x 48"L	1-7/8" to 6"	300	<b>348.00</b>	<b>310.00</b>

†SHIPPED CRATED WITHOUT HANDLE ATTACHED

DC-25/FC-70/92.5/175 ♦

\*MODEL PM4-2048-LP HAS A TRIANGULAR APRON

## Pallet Trucks with Digital Scale

The Pallet Truck with Digital Scale allows you to weigh your load on the spot for maximum efficiency. The frame uses heavy-duty steel construction for maximum strength and durability. This model is very user friendly and is suitable for low height lifting. The built-in scale allows you to weigh your load as you are handling it. The scale is selectable in a variety of increments to adjust to the size of your load. It has keyboard calibration and functional setup with automatic zero capabilities. Digital filtering is used to help compensate for vibration and motion to make the Pallet Truck with Digital Scale smooth and accurate. Forks are 7" wide each. Factory calibrated for shipping destination. Scale is powered with (6) D size batteries, AC adapter can be hooked up (not included).

MODEL NUMBER	CAPACITY (POUNDS)	OVERALL FORK DIMENSIONS	FORK SERVICE RANGE	NET WT. (POUNDS)	LIST PRICE EACH
PM-2048-SCL-LP	5,000	22-3/8"W x 48"L	3" to 7½"	338	<b>\$1,490.00</b>
PM-2748-SCL-LP	5,000	27-1/2"W x 48"L	3" to 7½"	371	<b>1,490.00</b>
PM-2048-SCL-LP-PT*	5,000	22-3/8"W x 48"L	3" to 7½"	343	<b>\$1,812.00</b>
PM-2748-SCL-LP-PT*	5,000	27-1/2"W x 48"L	3" to 7½"	378	<b>1,812.00</b>

\* PALLET TRUCK WITH SCALE AND PRINTER

DC-25/FC-70/175 ♦



## Ergonomic Power Assist Pallet Truck

Anyone who has operated a fully loaded pallet truck knows the most strenuous part is starting the wheels rolling. This Pallet Truck solves this back breaking problem. Pumping the handle of the pallet truck serves two purposes. First, it serves the traditional purpose of lifting the forks. Second, switch to the power drive accumulator and by pulling the handle back, the pallet truck begins to roll automatically, thus reducing the pulling force.

MODEL NUMBER	CAPACITY (POUNDS)	OVERALL FORK DIMENSIONS	FORK SERVICE RANGE	NET WT. (POUNDS)	LIST PRICE EACH
PM5-2748-PA-Y	5,000	27"W x 48"L	3" to 7½"	190	<b>TBD</b>

DC-25/FC-70/175 ♦



## All Terrain Pallet Truck

- Inside Straddle is 50" / Outside Straddle is 64"
- Pneumatic Tires have Sealed Bearings for Outside Durability

This lightweight yet strong tubular frame design handles evenly distributed loads up to 2,000 lbs. (2,000 lbs. at 12" horizontal load center and 1,500 lbs. at 15" horizontal load center). Large wheels allow for movement over most surfaces. Use at construction sites, gravel pits, and nurseries. Features large 16" front pneumatic tires and 10" pneumatic steering wheels. Individual forks are 4"W x 2"H. Easy to operate with three position handle, UP, DOWN, and NEUTRAL. Optional Tow Bar package allows the All Terrain Pallet Truck to be towed by an ATV or small utility tractor. Designed for pulling in either loaded or unloaded position.

MODEL NUMBER	*CAPACITY (POUNDS)	ADJUSTABLE FORK WIDTH	FORK LENGTH	SERVICE RANGE	OVERALL SIZE (W x L x H)	NET WT. (POUNDS)	LIST PRICE EACH
ALL-T-2	2,000	9½" to 26"	32"	3' to 9'	64" x 50" x 51"	410	\$629.00
ALL-TTB	OPTIONAL TOW BAR PACKAGE					62	155.00

\*2,000 lbs. at 12" horizontal load center and 1,500 lbs. at 15" horizontal load center

DC-25/FC-70/175♦



ADJUSTABLE WIDTH FORKS

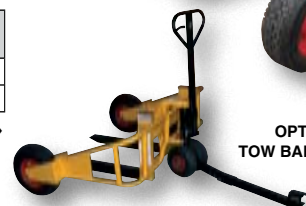

OPTIONAL TOW BAR PACKAGE

## Gas Powered All Terrain Pallet Trucks

All terrain pallet truck with gas-powered traction drive system. Great for moving heavy loads over rough terrain. Powered by a Briggs & Stratton 6HP gas-powered engine for both the power traction drive and fork lift/lower. Handle with forward reverse speed control and dead man safety switch. Hydrostatic transmission with hand-operated forward and reverse selection. Powered fork raise and lower controlled with independent levers. Usable width between outriggers is 50". Pneumatic steer wheels are 13" diameter x 4" wide each. The drive wheels are 18" diameter x 8½" wide each (foam filled pneumatic wheels on ALL-T-4-GPT standard). Wheels include sealed bearings for outdoor use. Steering arc is 150°.

MODEL NUMBER	*CAPACITY (POUNDS)	ADJUSTABLE FORK WIDTH	FORK (W x L)	SERVICE RANGE	OVERALL SIZE (W x L)	NET WT. (POUNDS)	LIST PRICE EACH
ALL-T-2-GPT	2,000	8" to 36"	4" x 36"	2-5/8" to 12"	79" x 68"	1200	\$6,229.00
ALL-T-4-GPT	4,000	8" to 36"	4" x 36"	2-5/8" to 12"	79" x 68"	1200	6,796.00

\*CAPACITY AT AN 18" LOAD CENTER

DC-25/FC-70/175♦



DVD or VIDEO AVAILABLE

## Big Wheel Pallet Truck

- Steering Wheels are 8" x 2" Poly-on-Steel
- Load Rollers are 4" x 3½"
- Does Not Work with Standard Pallets

Use less pushing or pulling force when transporting large heavy loads across floors with the Big Wheel Pallet Truck. An alternative to fork trucks, this unit makes it easier to move loaded tubs weighing up to 4,500 pounds. The raised height of 16-1/8" and the lowered height 6-1/2" enables the pallet truck to service high bottom tubs. The Big Wheel Pallet Truck retains all of the quality workmanship of our other Pallet Master Pallet Trucks.

MODEL NUMBER	DESCRIPTION	CAPACITY (POUNDS)	OVERALL FORK SIZE (W x L)	SERVICE RANGE	NET WT. (POUNDS)	LIST PRICE EACH
BW-PJ	BIG WHEEL	4,500	26-3/4" x 51-1/2"	5-1/2" to 15-1/2"	299	\$590.00

DC-25/FC-70/92.5/175♦



## Side Winder Pallet Truck

- Move Long Loads Down Narrow Aisles
- Moves FORWARD, BACKWARD, LEFT, and RIGHT
- Capacity is 3,000 pounds

Transport long loads down narrow aisles with this heavy-duty Sidewinder Pallet Truck. This versatile Pallet Truck retains all the quality workmanship of a standard pallet truck in addition to providing lateral movement. Simply place the forks into the pallet then elevate to approximately seven inches, rotate handle, and lock detent into place. The second set of rollers, right/left, are actuated. Now push the Side Winder perpendicular to the traditional direction.

MODEL NUMBER	DESCRIPTION	CAPACITY (POUNDS)	OVERALL FORK SIZE (W x L)	SERVICE RANGE	NET WT. (POUNDS)	LIST PRICE EACH
SW-PJ	SIDE WINDER	3,000	27" x 48"	3-1/2" to 8"	311	\$412.00

DC-25/FC-70/92.5/175♦



DVD or VIDEO AVAILABLE

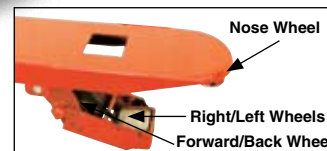
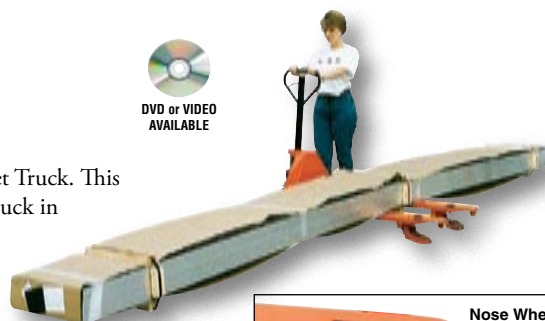



**New**

DVD or VIDEO  
AVAILABLE

## Fully Powered Electric Pallet Trucks

Fully powered pallet truck for easy and quick operation. Includes fingertip raise and lower buttons. Easy-to-operate throttle for forward and reverse direction. Throttle offers infinite forward and reverse speeds. Safety features include a horn and belly reverse button. Units run off 24V batteries with battery charger standard. The 3,000 pound capacity models use two 12V batteries with 70Ah rating. The 4,500 pound capacity models use four 12V batteries with 180Ah rating. Units will typically achieve a minimum of eight (8) hours of service on one full charge. The Non-Adjustable Pallet Jockey, model PJ-1005, will convert the EPT-2748-45 (only) into a Walkie Truck, see page 67.

MODEL NUMBER	CAPACITY* (POUNDS)	FORK SIZE (W x L)	SERVICE RANGE	OVERALL SIZE (W x L x H)	NET WT. (LBS.)	LIST PRICE EACH
EPT-2047-30	3,000	20" x 47"	3.2" to 7.8"	28" x 65" x 49"	660	\$2,938.00
EPT-2547-30	3,000	25" x 47"	3.2" to 7.8"	28" x 65" x 49"	671	2,728.00
EPT-2048-45	4,500	20" x 48"	3.4" to 8"	30" x 78½" x 49"	990	\$4,982.00
EPT-2748-45	4,500	27" x 48"	3.4" to 8"	30" x 78½" x 49"	1012	4,667.00

\*CONTINUOUS DUTY RATING / ADD 500 LBS. CAPACITY FOR INTERMITTENT DUTY RATING

DC-25/FC-70

## Wheel Nose Pallet Trucks

- Take the Guess Work Out of Close Pallet Placement
- Optimize Floor and Truck Space with this Innovative Pallet Truck

The Wheel Nose Pallet Truck is designed to position pallets or skids closely together. The fork end is set back from the front rollers allowing for one pallet pick up at a time. The unit has a rubber grip handle with a three position lever for easy operation and maneuvering. This heavy-duty unit is rated at 5,000 pounds capacity and has a service range from 3½" to 8". Unit includes two articulating steering wheels and two front load rollers. Spring loaded loop handle automatically returns to vertical position when not in use. 38" forks are used for maneuvering in tight spaces.

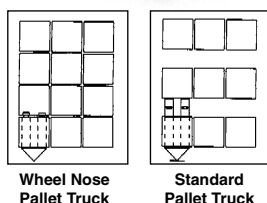

Wheel Nose  
Pallet Truck

Standard  
Pallet Truck

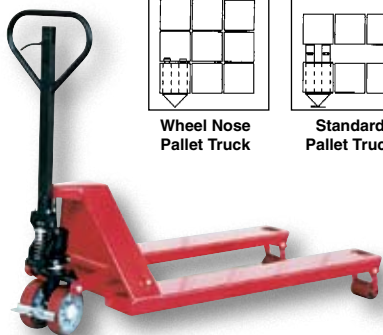

MODEL NUMBER	DESCRIPTION	CAPACITY (POUNDS)	OVERALL FORK SIZE (W x L)	SERVICE RANGE	NET WT. (POUNDS)	LIST PRICE EACH
PM5-2038-WN	WHEEL NOSE	5,000	20" x 38"	3½" to 8"	260	\$395.00
PM5-2738-WN	WHEEL NOSE	5,000	27" x 38"	3½" to 8"	280	395.00

DC-25/FC-70/92.5/175♦

## Specialized Pallet Trucks (with nylon wheels)

- Pallet Trucks for Corrosive and Sanitary Environments

### STAINLESS STEEL AND STAINLESS STEEL FRAME & FORKS

Ideal for sanitary, pharmaceutical, medical, food, and wet environments. Choose either type 304 stainless steel frame and forks only or 100% type 304 stainless steel pallet truck for long life in even the most harsh environments. 5,500 lbs. capacity.

### GALVANIZED AND ZINC PLATED

Designed for corrosive or wet environments, these full-featured pallet trucks were designed for chemical, pharmaceutical and wash-down applications. 5,500 lbs. capacity.



MODEL NUMBER	DESCRIPTION	OVERALL FORK DIMENSIONS	FORK SERVICE RANGE	NET WT. (LBS.)	LIST PRICE EACH
PM5-2048-SS	STAINLESS STEEL	20"W x 48"L	2-7/8" to 7-3/4"	300	\$1,690.00
PM5-2748-SS	STAINLESS STEEL	27"W x 48"L	2-7/8" to 7-3/4"	327	1,690.00
PM5-2748-SFF	SS FRAME & FORKS	27"W x 48"L	2-7/8" to 7-3/4"	327	928.00
PM5-2748-S-G	GALVANIZED	27"W x 48"L	2-7/8" to 7-3/4"	327	465.00
PM5-2748-S-Z	ZINC COATED	27"W x 48"L	2-7/8" to 7-3/4"	322	465.00

DC-25/FC-70/92.5/175♦

## Skid Adapters for Pallet Trucks

Increase your pallet truck service by 3" to handle skids with the Skid Adapter. Adapts to model PM5- "Pallet Master Pallet Trucks" only with an overall fork width of either 20" or 27" and a minimum fork length of 48". Skid adapter may be rotated into vertical position for normal pallet truck use.

MODEL NUMBER	DESCRIPTION	ACCOMMODATES FORK DIMENSIONS	INCREASED HEIGHT	NET WT. (POUNDS)	LIST PRICE EACH
PM5-20SA	SKID ADAPTERS	20"W x 48"L	3"	60	\$125.00
PM5-27SA	SKID ADAPTERS	27"W x 48"L	3"	75	135.00

DC-25/FC-70/92.5/175♦

## Pallet Truck Wedge with Magnet

Prevent pallet truck damage in moving semi-trailers with the Pallet Truck Wedge. Constructed of 100% molded urethane. Step-down design for use with all types of pallet trucks. Magnetic back for securing to pallet truck for storage. Lightweight and easy to use.

MODEL NUMBER	DESCRIPTION	OVERALL SIZE (W x L x H)	NET WT. (POUNDS)	LIST PRICE EACH
PJ-4	PALLET TRUCK WEDGE	4" x 5¾" x 2¼"	3	\$19.50

DC-35/UPS

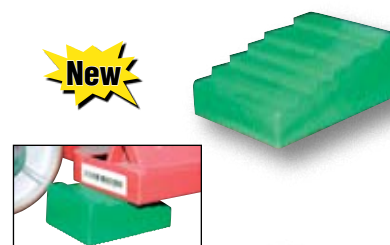

## Pallet Truck Stop

This unique pallet truck stop was designed to eliminate freight and trailer door damage due to runaway pallet trucks. It is easy to use, easy, and store. It protects valuable freight and equipment from damage caused when a pallet truck drifts. Ideal for freight companies, delivery companies, and other material handling customers.

MODEL NUMBER	DESCRIPTION	OVERALL SIZE (W x L x H)	USABLE SIZE (W x L)	NET WT. (POUNDS)	LIST PRICE EACH
VPTS-05	PALLET TRUCK STOP	11½" x 11½" x 2"	8-7/8" x 5-7/8"	3	\$42.00

DC-20/UPS



## Battery Transfer Cart

Battery Transfer Cart is designed for use with pallet trucks to load, unload, and transfer fork truck batteries. Features roller deck for easy battery movement. Front locking safety tabs to secure battery in cart. Pallet truck is not included. Welded steel construction with powder coat yellow finish.

The stand alone Battery Transfer Cart, model BTC-CART, includes casters for portability. Specify roller height when ordering.

Optional winch attachment, model BTC-WINCH, can be installed easily to either BTC unit with the supplied hardware. The manual winch is designed to pull battery out of fork truck.

MODEL NUMBER	DESCRIPTION	OVERALL SIZE (W x L x H)	CAPACITY (POUNDS)	NET WT. (POUNDS)	LIST PRICE EACH
BTC-PJ	FOR USE W/PALLET TRUCK	34" x 42" x 17"	4,000	140	\$561.00
BTC-CART*	STAND ALONE CART	30" x 40"	4,000	250	716.00
BTC-WINCH	WINCH ATTACHMENT	46"H	--	30	649.00

\*SPECIFY ROLLER HEIGHT WHEN ORDERING

DC-25/FC-70



## Pallet Jockey for "Walkie" Trucks

- Eliminate the Use of Fork Trucks for Unloading
- Maximize Your Trailer Loads and Profits
- Reduce Work Related Injuries



The Pallet Jockey is a simple device that allows drivers and warehouse personnel to efficiently unload sideways pallets with their "Walkie" powered pallet trucks without wasting valuable time and resources.

The Non-Adjustable unit is ideal for warehouse distribution centers that have one particular electric pallet truck model. To use simply place the Pallet Jockey hooks into the fork wheel openings. Fits both Raymond and Crown brand walkie trucks and our electric pallet truck, model EPT-2748-45.

The Adjustable unit is designed to fit various types of electric pallet jacks. To use simply loosen wing bolts and slide adjustable brackets to proper slot, then tighten wing bolts.

MODEL NUMBER	DESCRIPTION	POWERED PALLET TRUCK STYLE IT WORKS WITH	NET WT. (LBS.)	LIST PRICE EACH	PRICE FOR 6 OR MORE
PJ-1005	Non-Adjustable	Raymond & Crown Electric	25	\$179.00	\$159.00
PJ-2001	Adjustable	Various Electric Walkie Trucks	26	199.00	179.00

DC-25/UPS/FC-70

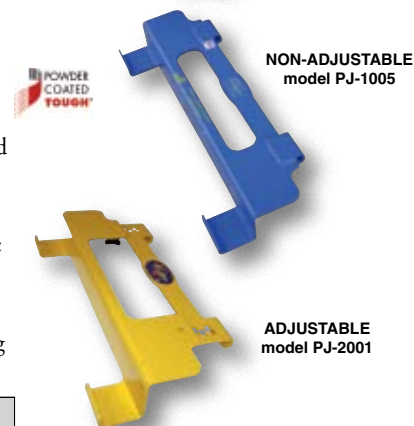

## Moving Pad with Velcro Straps for Hand Trucks

Minimize scratches and damage to your belongings. Durable yet attractive pads fit most hand trucks with nose plate up to 14" wide. Two velcro wraps and one velcro nose wrap. Easy to install.

MODEL NUMBER	DESCRIPTION	OVERALL SIZE (W x H)	NET WT. (POUNDS)	LIST PRICE EACH
QPC-HT	MOVING PAD FOR HAND TRUCK	16" x 50"	3	\$19.90

DC-25/UPS







ALUMINUM  
model FHC-250



PLASTIC  
model FHC-75

## Foldaway Hand Trucks

The Aluminum Fold-Up Hand Truck, *model FHC-250*, is designed for everyday all purpose use. Perfect for a sales person, students, and maintenance personnel. The handle and wheels fold up quickly and easily allowing you to store it in tight spaces such as trunks of cars, under tables, or in closets.

The Plastic Fold-Up Hand Truck, *model FHC-75*, handles small loads up to 75 pounds. The crate can hold small parts, groceries, recycling goods, etc. The fold up design allows you take it with you wherever you travel; trade shows, airports, or conferences.

MODEL NUMBER	FOLDED SIZE (W x L x H)	SIZE UNFOLDED (W x L x H)	CAPACITY (POUNDS)	NET WT. (POUNDS)	LIST PRICE EACH	PRICE FOR TWO OR MORE
FHC-250	19" x 2¾" x 26"	19" x 17" x 40½"	250	16	\$89.00	\$74.00
FHC-75	19" x 3¼" x 16¾"	16" x 13" x 31½"	75	8	24.00	18.00

DC-25/UPS/FC-100



DUAL WHEELS  
model SPHT-500S-DW



## 4 Wheel Pneumatic/Hard Rubber Hand Truck

The most versatile and easy moving hand truck available. The 4 wheel design, 2 pneumatic and 2 hard rubber, allows the operator to easily move and position awkward loads. The tires and the load determine how much the hand truck rubber wheels are utilized. Ideal on rough floors and with awkward heavy loads.

MODEL NUMBER	NOSE PLATE (W x D)	OVERALL SIZE (W x D x H)	CAPACITY (POUNDS)	NET WT. (POUNDS)	LIST PRICE EACH	PRICE FOR TWO OR MORE
SPHT-500S-DW	22" x 7"	22" x 19" x 52"	600	75	\$81.00	

DC-25/UPS/FC-100+



LEFT/RIGHT



FORWARD  
BACKWARD

## Dual Directional Hand Truck

The Dual Directional Hand Truck works great as a standard two-wheel hand truck or as a panel cart. This unit allows the user to transport loads forward/backward or left/right. You can transport loads of crates or boxes, or, by turning the 8" x 2" mold-on-rubber wheels, you can turn the hand truck into a panel cart. Moving down narrow aisles or doorways is no longer a problem with the adjustable wheels and easy steering. Steel construction. Painted finish.

MODEL NUMBER	NOSE PLATE (W x D)	OVERALL SIZE (W x D x H)	CAPACITY (POUNDS)	NET WT. (POUNDS)	LIST PRICE EACH	PRICE FOR TWO OR MORE
DDT-500	14" x 8"	20" x 18" x 51"	600	55	\$86.00	\$80.00

DC-25/UPS/FC-100+



STEEL  
model DHHT-500S



ALUMINUM  
model DHHT-500A

## Dual Handle Hand Trucks

Maximize control for different loads with heavy-duty Dual Handle Hand Trucks. These hand trucks can transport boxes or crates wherever they are needed. Transport loads smoothly and evenly over rough or uneven floors. Ships knockdown. Choose steel or aluminum, available with pneumatic or solid rubber wheels.

STEEL DUAL HANDLE HAND TRUCKS						
MODEL NUMBER	NOSE PLATE (W x D)	CAPACITY (POUNDS)	OVERALL SIZE (W x D x H)	NET WT. (POUNDS)	LIST PRICE EACH	PRICE FOR TWO OR MORE
10" x 2½" SOLID RUBBER WHEELS						
DHHT-500S-HR	13¾" x 6½"	500	21" x 17½" x 44½"	36	\$48.00	\$42.00
10" x 3½" PNEUMATIC WHEELS						
DHHT-500S	13¾" x 6½"	500	22½" x 17½" x 44½"	36	\$43.00	\$38.00

DC-25/UPS/FC-100+

ALUMINUM DUAL HANDLE HAND TRUCKS						
MODEL NUMBER	NOSE PLATE (W x D)	CAPACITY (POUNDS)	OVERALL SIZE (W x D x H)	NET WT. (POUNDS)	LIST PRICE EACH	PRICE FOR TWO OR MORE
10" x 2½" SOLID RUBBER WHEELS						
DHHT-500A-HR*	14" x 8½"	300	20" x 20" x 49"	36	\$103.00	\$91.00
DHHT-500A-ANP-HR*	18" x 7½"	300	20½" x 19" x 50"	34	109.00	96.00
10" x 3½" PNEUMATIC WHEELS						
DHHT-500A	14" x 8½"	300	20" x 20" x 49"	32	\$98.00	\$87.00
DHHT-500A-ANP*	14" x 8½"	300	20½" x 19" x 50"	30	103.00	90.00

\*SUFFIX ANP NOTES ALUMINUM NOSE PLATE

DC-25/UPS/FC-100+

## Fiber/Nylon Hand Truck

Transport lightweight loads with this Fiber/Nylon Hand Truck. The unique construction is stronger than steel, yet lighter and more cost effective than aluminum. The 10" x 3½" pneumatic wheels provide a smooth ride and years of durability. Capacity is 500 pounds.

MODEL NUMBER	NOSE PLATE (W x D)	CAPACITY (POUNDS)	OVERALL SIZE (W x D x H)	NET WT. (POUNDS)	LIST PRICE EACH	PRICE FOR TWO OR MORE
FNHT-500	14" x 7"	500	20" x 48"	26	\$70.00	\$62.00

DC-25/UPS/FC-100+



FIBER/NYLON  
model FNHT-500



ALUMINUM NOSE PLATE  
model DHHT-500A-ANP

## "P" Handle Hand Trucks

The "P" style hand trucks are ideal for transporting heavy and awkward loads. These trucks work well for the user that needs to free up one hand. The "P" shaped handle makes the truck easy to steer and maneuver.

STEEL "P" HANDLE HAND TRUCKS						
MODEL NUMBER	NOSE PLATE (W x D)	CAPACITY (POUNDS)	OVERALL SIZE (W x D x H)	NET WT. (POUNDS)	LIST PRICE EACH	PRICE FOR TWO OR MORE
<b>10" x 2" HARD RUBBER WHEELS</b>						
SPHT-500S-HR	13¾" x 7½"	500	21" x 18" x 52"	51	\$45.00	\$40.00
SPHT-500S-HD-HR*	22" x 7"	600	22" x 19" x 52"	64	50.00	45.00
<b>10" x 3½" PNEUMATIC WHEELS</b>						
SPHT-500SⓈ	13¾" x 7½"	500	21" x 18" x 52"	37	\$40.00	\$36.00
SPHT-500S-HD*	22" x 7"	600	22" x 19" x 52"	51	45.00	39.00
<b>13" x 4" PNEUMATIC WHEELS</b>						
SPHT-600S-IND	13¾" x 7½"	600	21" x 18" x 52"	37	\$49.00	\$43.00

\*SHIPS TRUCK ONLY

DC-25/UPS/FC-100♦

ALUMINUM "P" HANDLE HAND TRUCKS						
MODEL NUMBER	NOSE PLATE (W x D)	CAPACITY (POUNDS)	OVERALL SIZE (W x D x H)	NET WT. (POUNDS)	LIST PRICE EACH	PRICE FOR TWO OR MORE
<b>10" x 2" HARD RUBBER WHEELS</b>						
APHT-500A-HR	14" x 7½"	300	20" x 19" x 50½"	46	\$100.00	\$90.00
<b>10" x 3½" PNEUMATIC WHEELS</b>						
APHT-500A	14" x 7½"	300	20" x 19" x 50½"	32	\$96.00	\$88.00

DC-25/UPS/FC-100♦

STAINLESS STEEL "P" HANDLE HAND TRUCKS						
MODEL NUMBER	NOSE PLATE (W x D)	CAPACITY (POUNDS)	OVERALL SIZE (W x D x H)	NET WT. (POUNDS)	LIST PRICE EACH	PRICE FOR TWO OR MORE
<b>10" x 2" HARD RUBBER WHEELS</b>						
SPHT-500-HD-SS-HR*	22" x 7"	600	22" x 19" x 52"	66	\$166.00	\$115.00
SPHT-500-SS-HR	13¾" x 7½"	500	21" x 18" x 52"	51	139.00	88.00
<b>10" x 3½" PNEUMATIC WHEELS</b>						
SPHT-500-HD-SS	22" x 7"	600	22" x 19" x 52"	51	\$159.00	\$112.00
SPHT-500-SS	13¾" x 7½"	500	21" x 18" x 52"	37	131.00	84.00

\*SHIPS TRUCK ONLY

DC-25/UPS/FC-100♦

AXLE AND WHEEL HUB NOT STAINLESS STEEL

## Site Cart/Truck



This large cart with big wheels works great to move items around in rough terrain. Landscaping is easier due to the oversized nose plate (holds scrub balls for transport). The pneumatic wheels are 16" x 4½". Welded steel construction with powder coat yellow finish.

MODEL NUMBER	NOSE PLATE (W x D)	CAPACITY (POUNDS)	OVERALL SIZE (W x D x H)	NET WT. (POUNDS)	LIST PRICE EACH	PRICE FOR TWO OR MORE
SITE-C	22½" x 16"	600	34" x 24" x 55½"	70	\$193.00	\$189.00

DC-25/FC-100♦

## Convertible Hand Trucks

The Aluminum & Steel Convertible Hand Trucks are versatile wonders. These hand trucks can work in both the vertical and horizontal positions. The task of transporting smaller crates or long narrow boxes is now simplified. These carts roll smoothly on 10" x 3½" rigid pneumatic and 4" x 1" swivel solid rubber casters. Ships knockdown.



CSHT-500

DSHT-500-PN

CAHT-500

	MODEL NUMBER	DESCRIPTION	NOSE PLATE (W x D)	CAPACITY (POUNDS)	OVERALL SIZE (W x D x H)	NET WT. (POUNDS)	LIST PRICE EACH	PRICE FOR TWO OR MORE
HAND TRUCK	CAHT-500Ⓢ	ALUMINUM	17¾" x 7¾"	500	20" x 20" x 54"	41 (UPS)	\$174.00	\$153.00
PLATFORM TRUCK				650	20" x 49" x 41"			
HAND TRUCK	DSHT-500-PN	STEEL	13¾" x 7½"	500	22" x 19" x 49"	61 (UPS)	\$81.00	\$71.00
PLATFORM TRUCK				500	22" x 42" x 36"			
HAND TRUCK	CSHT-500	STEEL	10¼" x 7½"	600	19½" x 20" x 57¾"	69	\$112.00	\$97.00
PLATFORM TRUCK				650	19½" x 42" x 37"			

DC-25/UPS/FC-100♦



SPHT-500S Galvanized Finish

SPHT-500S-HD-HR



SPHT-600S-IND

APHT-500A



SPHT-500-HD-SS Stainless Steel

SITE-C Site Cart / Truck

## Deluxe Aluminum Hand Trucks

Maximize control for different types of loads. These hand trucks can transport boxes wherever they are needed. Transport loads smoothly and evenly over rough or uneven floors. 10" x 3½" pneumatic tires are standard on all hand trucks. 10" x 2½" industrial solid rubber tires also available. The convertible hand truck has 10" x 3½" pneumatic tires and 5" x 1¼" poly-on-steel swivel casters. Optional stair guides are available.



model ALUM-P      model ALUM-H      model ALUM-LOOP      model ALUM-LOOP-H      model ALUM-CONV      model ALUM-CONV-B

	MODEL NUMBER	DESCRIPTION	NOSE PLATE (W x D)	CAPACITY (POUNDS)	OVERALL SIZE (W x D x H)	NET WT. (POUNDS)	LIST PRICE EACH	PRICE FOR TWO OR MORE
	ALUM-P	"P" HANDLE	14" x 7¼"	500	21" x 19" x 52½"	25	\$119.00	\$97.00
	ALUM-H	DUAL HANDLE	14" x 7¼"	500	21" x 19" x 52"	25	120.00	98.00
	ALUM-LOOP	LOOP HANDLE	18" x 9"	500	21" x 19" x 49"	27	123.00	101.00
	ALUM-LOOP-H	LOOP HANDLE	18" x 9"	500	21" x 22" x 49"	28	131.00	106.00
HAND TRUCK	ALUM-CONV	CONVERTIBLE	18" x 7¼"	500	20½" x 19" x 52"	40	\$172.00	\$135.00
PLATFORM TRUCK				750	47" x 20½" x 52"			
HAND TRUCK	ALUM-CONV-B	CONVERTIBLE	18" x 7¼"	500	20½" x 19" x 61½"	40	\$189.00	\$146.00
PLATFORM TRUCK				750	57" x 20½" x 45½"			

10" x 2½" SOLID RUBBER WHEELS, model ALUM-HR, \$5.00 LIST  
 OPTIONAL STAIR GUIDES, model ALUM-SG, \$12.00 LIST

DC-25/UPS/FC-100♦

## Four Wheel Multi-Position Steel Hand Truck

This hand truck is great for uneven surfaces and outdoor work. Small 4" x 1¼" mold-on-rubber swivel casters are located at the back of the cart to stabilize loads and prevent tipping. The back casters will also transform the unit into a horizontal platform truck. The unit will lie back horizontally, the handle will release to a standard position, and now the cart is a platform truck. 10" x 3½" pneumatic casters. Ships knockdown.



48 Hours to Ship

MODEL NUMBER	NOSE PLATE (W x D)	CAPACITY (POUNDS)	OVERALL SIZE (W x D x H)	NET WT. (POUNDS)	LIST PRICE EACH	PRICE FOR TWO OR MORE
TWC-400Ⓢ	16¼" x 12"	400	23¾" x 22" x 50"	47	\$85.00	\$75.00

DC-25/FC-100♦

## Aluminum Ergonomic Hand Truck

Heavy-duty construction, yet lightweight aluminum design, provides superior control. This unit has knuckle guard handles, fold up nose plate, and curved back plate for transporting cylindrical objects. Transporting down stairs or steep hills is no problem with this unit. 10" x 3½" pneumatic wheels are standard. Ships knockdown.



48 Hours to Ship

MODEL NUMBER	NOSE PLATE (W x D)	CAPACITY (POUNDS)	OVERALL SIZE (W x D x H)	NET WT. (POUNDS)	LIST PRICE EACH	PRICE FOR TWO OR MORE
AMPC-500Ⓢ	11" x 11"	350	21" x 25" x 57½"	26	\$206.00	\$182.00

DC-25/UPS/FC-100♦

## High Back Aluminum Hand Truck with Push Out

The High Back Aluminum Hand Truck with Push Out will transport tall heavy loads weighing up to 300 pounds from workstation to workstation. When the load has reached its final destination, the user simply pushes down on the back plate with their foot and the plate on the front of the unit will slide the load off. This feature reduces stress on the user's back. 8" x 1¾" semi-pneumatic wheels. Ships knockdown.

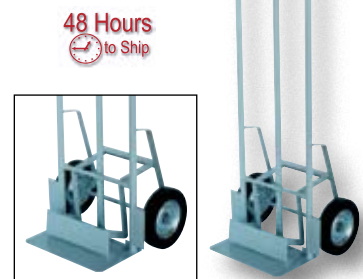

48 Hours to Ship

MODEL NUMBER	NOSE PLATE (W x D)	CAPACITY (POUNDS)	OVERALL SIZE (W x D x H)	NET WT. (POUNDS)	LIST PRICE EACH	PRICE FOR TWO OR MORE
HBST-500Ⓢ	13½" x 7¼"	200	18" x 17" x 55"	42	\$122.00	\$108.00

DC-25/UPS/FC-100♦



## Appliance Carts

This cart is ideal for moving large, bulky, heavy appliances, and awkward loads. A strap and tension bar are included with this unit to hold the product in place while transporting up or down stairways, hills, or uneven surfaces.

The lightweight aluminum Appliance Cart is ideal for moving companies and delivery trucks.



model APPL-500



series APPL-1200



model APPL-500-Y



model APPL-500-A

MODEL NUMBER	DESCRIPTION	OPERATION	NOSE PLATE (W x D)	CAPACITY (POUNDS)	OVERALL SIZE (W x D x H)	CASTER SIZE	NET WT. (POUNDS)	LIST PRICE EACH	PRICE FOR TWO OR MORE
APPL-500 <sup>®</sup>	STEEL	TURN HANDLE	24" x 3¾"	500	24" x 12" x 59½"	8" x 2½"	47	\$98.00	\$88.00
APPL-1200-60	STEEL	RATCHET	24" x 5¼"	1,200	24" x 15" x 60"	8" x 2"*	66	238.00	211.00
APPL-1200-66	STEEL	RATCHET	24" x 5¼"	1,200	24" x 15" x 66"	8" x 2"*	70	245.00	216.00
APPL-1200-72	STEEL	RATCHET	24" x 5¼"	1,200	24" x 15" x 72"	8" x 2"*	74	251.00	222.00
APPL-500-Y	STEEL	RATCHET	24" x 4¾"	500	24" x 12" x 60"	6" x 2"	47	98.00	87.00
APPL-500-A	ALUMINUM	TURN HANDLE	24" x 3¾"	350	24½" x 13" x 60"	8" x 2½"	34	\$168.00	\$132.00

\*ALSO INCLUDES (2) 3½" x 1½" MOLD-ON-RUBBER SWIVEL REAR CASTERS

DC-25/FC-100+

## Steel Stair Hand Truck

Unique design features tandem triple-wheel assemblies that work great when going up and down stairs. Wheel assembly smoothly rotates as you go up or down each step - eliminates the thud and bump associated with conventional two wheel hand trucks on stairs. Caution - do not use more weight than you can safely handle. Rear wheel assembly also allows hand truck to roll easily on 4 wheels while on flat surfaces. Single loop handle. Steel construction. Painted finish.

MODEL NUMBER	NOSE PLATE (W x D)	CAPACITY (POUNDS)	OVERALL SIZE (W x D x H)	NET WT. (POUNDS)	LIST PRICE EACH
ST-TRUCK-300	13½" x 15¾"	300	24" x 32" x 45¾"	38	\$84.00

DC-20/FC-100+



## Stair Hand Truck (Four Handles)

Quick and easy way for two people to transport a loaded hand truck up and down stairways or hills. Easy grip handles provide comfort to persons using hand truck. Removable handles conveniently store on back of hand truck when not in use. Steel construction. 10" x 3½" pneumatic wheels.

MODEL NUMBER	NOSE PLATE (W x D)	CAPACITY (POUNDS)	OVERALL SIZE (W x D x H)	NET WT. (POUNDS)	LIST PRICE EACH
HAND-TPE	13¾" x 6½"	500	21" x 17½" x 44½"	44	\$105.00

DC-25/UPS/FC-100+



## Multi-Function Luggage Cart/Chair

The Multi-Function Luggage Cart/Chair is constructed of both steel and plastic. Cart will handle lightweight loads up to 65 pounds. The chair position holds up to 225 pounds. This Cart/Chair is perfect for use at trade shows for transporting products, literature and small parts. (2) 3" x ¾" hard rubber wheels are standard.

MODEL NUMBER	FOLDED SIZE (W x L x H)	SEAT SIZE (W x L x H)	LUGGAGE LIP (W x L)	CHAIR/LUGGAGE CAPACITY (LBS.)	NET WT. (POUNDS)	LIST PRICE EACH
LC-803	13" x 26½" x 3½"	12" x 13" x 17"	9" x 12"	225 / 65	8	\$26.00

DC-25/UPS



## Furniture and Crate Movers

Transport furniture, crates, and machinery easily. Simply slide nose plate under item to be moved, strap both dollies together, and lift. Available in either a manual mechanical hand crank lift option or a manual hand pump hydraulic lift option. Standard with (4) 6" x 2" swivel poly-on-steel casters and straps. Steel construction with durable paint finish. Priced and sold in pairs.



model MFM-1300

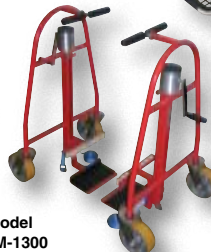

model MFM-4000

MODEL NUMBER	LIFT STYLE	PLATE SIZE (W x D)	CAPACITY (POUNDS)	LIFT HEIGHT	OVERALL SIZE (W x D x H)	NET WT. (POUNDS)	LIST PER PAIR
MFM-1300	MECHANICAL	8¾" x 4¾"	1,300	11¾"	15½" x 22½" x 30¾"	60	\$373.00
MFM-4000	HYDRAULIC	23½" x 2¼"	4,000	10"	16½" x 26¾" x 42¼"	190	506.00

DC-25/FC-100

## Adjustable Work-Mate Stands

Minimizes fatigue by elevating workers to heights that are comfortable and ergonomically correct. Especially useful when multiple shift employees operate the same piece of machinery. Serrated style platforms ensure safe footing in most wet environments. Ergonomic matting deck style provides comfort for the operator who stands all day. The height of each leg can be adjusted individually to ensure proper working height. All sizes have four legs except the 60", 72" and 96" long models which have six legs. Powder coated safety yellow finish. Welded steel construction.

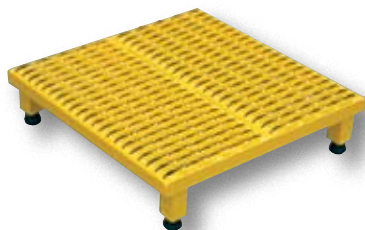

SERRATED DECK



Threaded Screw Legs are standard on AHW, AHT and ASP



48 Hours to Ship

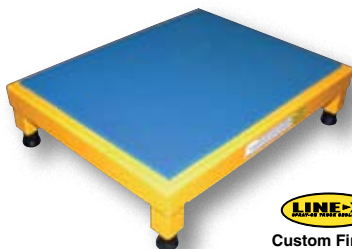

LINE-X Custom Finish Available

ERGO-MATTING DECK



model ASP-36

48 Hours to Ship

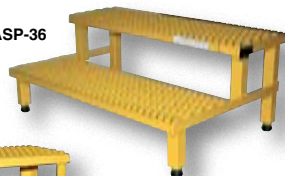

model ASP-36-3

**New**

Optional Portability Kit model ASP-PORT Bolt-on feature for transporting Step-Mate Stands



SERRATED DECK							
MODEL NUMBER	DECK SIZE (W x L)	LOWERED HEIGHT	RAISED HEIGHT	CAPACITY (POUNDS)	NET WT. (POUNDS)	LIST PRICE EACH	
AHW-L-1924	19" x 24"	5"	8"	500	22	\$145.00	
AHW-L-2424	24" x 24"	5"	8"	500	30	156.00	
AHW-L-1936	19" x 36"	5"	8"	500	35	172.00	
AHW-L-2436	24" x 36"	5"	8"	500	40	\$181.00	
AHW-L-1948	19" x 48"	5"	8"	500	44	192.00	
AHW-L-2448	24" x 48"	5"	8"	500	49	203.00	
AHW-L-2460	24" x 60"	5"	8"	500	59	\$224.00	
AHW-L-2472	24" x 72"	5"	8"	500	72	279.00	
AHW-L-2496	24" x 96"	5"	8"	500	94	365.00	
AHW-H-1924	19" x 24"	9"	14"	500	42	\$173.00	
AHW-H-2424	24" x 24"	9"	14"	500	48	178.00	
AHW-H-1936	19" x 36"	9"	14"	500	50	185.00	
AHW-H-2436	24" x 36"	9"	14"	500	54	\$192.00	
AHW-H-1948	19" x 48"	9"	14"	500	58	201.00	
AHW-H-2448	24" x 48"	9"	14"	500	60	211.00	
AHW-H-2460	24" x 60"	9"	14"	500	68	\$235.00	
AHW-H-2472	24" x 72"	9"	14"	500	78	291.00	
AHW-H-2496	24" x 96"	9"	14"	500	102	389.00	
ERGO-MATTING DECK							
MODEL NUMBER	DECK SIZE (W x L)	LOWERED HEIGHT	RAISED HEIGHT	CAPACITY (POUNDS)	NET WT. (POUNDS)	LIST PRICE EACH	
AHT-L-1924	19" x 24"	5"	8"	500	25	\$170.00	
AHT-L-2424	24" x 24"	5"	8"	500	33	187.00	
AHT-L-1936	19" x 36"	5"	8"	500	38	209.00	
AHT-L-2436	24" x 36"	5"	8"	500	44	\$229.00	
AHT-L-1948	19" x 48"	5"	8"	500	47	242.00	
AHT-L-2448	24" x 48"	5"	8"	500	52	266.00	
AHT-L-2460	24" x 60"	5"	8"	500	63	\$303.00	
AHT-L-2472	24" x 72"	5"	8"	500	76	373.00	
AHT-L-2496	24" x 96"	5"	8"	500	100	490.00	
AHT-H-1924	19" x 24"	9"	14"	500	48	\$198.00	
AHT-H-2424	24" x 24"	9"	14"	500	54	210.00	
AHT-H-1936	19" x 36"	9"	14"	500	56	222.00	
AHT-H-2436	24" x 36"	9"	14"	500	60	\$239.00	
AHT-H-1948	19" x 48"	9"	14"	500	64	250.00	
AHT-H-2448	24" x 48"	9"	14"	500	66	274.00	
AHT-H-2460	24" x 60"	9"	14"	500	74	\$313.00	
AHT-H-2472	24" x 72"	9"	14"	500	84	386.00	
AHT-H-2496	24" x 96"	9"	14"	500	110	515.00	

DC-25/FC-50

## Adjustable Step-Mate Stands

Our Step-Mate Stands can be used as either a comfortable worker platform or a semi-permanent step. Individual step size is 12" deep. Top step is fixed 7" higher than bottom step. Serrated steel surface ensures safe footing. Legs adjust individually by screwing them into or out of the leg base. Powder coated safety yellow finish. Welded steel construction. Capacity 500 pounds.

MODEL NUMBER	OVERALL SIZE (W x D)	FIRST STEP	SECOND STEP	THIRD STEP	NET WT. (POUNDS)	LIST PRICE EACH
ASP-24	24" x 24"	6" TO 10½"	13" TO 17½"	N/A	25	\$188.00
ASP-36	36" x 24"	6" TO 10½"	13" TO 17½"	N/A	33	203.00
ASP-48	48" x 24"	6" TO 10½"	13" TO 17½"	N/A	38	221.00
ASP-60	60" x 24"	6" TO 10½"	13" TO 17½"	N/A	44	245.00
ASP-72	72" x 24"	6" TO 10½"	13" TO 17½"	N/A	47	303.00
ASP-24-3	24" x 36"	6" TO 10½"	13" TO 17½"	20" TO 24½"	40	\$258.00
ASP-36-3	36" x 36"	6" TO 10½"	13" TO 17½"	20" TO 24½"	51	269.00
ASP-48-3	48" x 36"	6" TO 10½"	13" TO 17½"	20" TO 24½"	62	281.00

OPTIONAL PORTABILITY KIT, model ASP-PORT, \$26.90 LIST

DC-25/FC-50

## Serrated Steel Fold-Up Step

Easily rotate step to vertical position when not in use. Step is steel with powder coat blue finish and has a serrated surface for traction. Two 7/16" diameter mounting holes included. Fasteners are not included.

MODEL NUMBER	DESCRIPTION	STEP SIZE (W x D)	CAPACITY (POUNDS)	NET WT. (POUNDS)	LIST PRICE EACH
SFS-149	FOLD-UP STEP	14" x 9"	350	25	\$75.00

DC-25/UPS/FC-50



## Linearizer Electric Worker Platforms

Designed to raise or lower a worker to optimum working height for maximum productivity with minimum risk of back injury and fatigue. Typical applications include packaging stations, heavy machinery such as drill presses, lathes and saws, individual work cells, or work areas where height is a problem. Lifting source is a low maintenance electric linear actuator. An ergonomic anti-fatigue mat is included on the platform. Two rigid casters on the back side are used to facilitate ease of movement.

Unit is operated with a pendant hand held push button control on an 8' cord. Available with either 115V AC or a DC power pack. Shop air power option is also available.

MODEL NUMBER	PLATFORM SIZE (W x L)	LOWERED HEIGHT	RAISED HEIGHT	CAPACITY (POUNDS)	OPERATION	NET WT. (POUNDS)	LIST PRICE EACH
WP-400-AC	36" x 24"	2"	14"	400	115V AC POWER	288	\$984.00
WP-400-DC	36" x 24"	2"	14"	400	12V DC POWER	299	984.00
WP-400-AIR	36" x 24"	2"	14"	400	FACTORY AIR	288	984.00

DC-25/FC-70



Custom Finish Available

## Posi-Crank Worker Platforms

The Posi-Crank ergonomic work station is an economical variable height work positioner. With a simple turn of a crank, the platform height may be adjusted to the optimum ergonomic level suitable for each operator. Benefits of the Posi-Crank include minimizing the risk of cumulative trauma injuries, back injuries and fatigue, while maximizing efficiency and operator morale.

The Posi-Crank incorporates the use of ACME threaded rods and a series of gears for simple yet effective height adjustment. The crank handle may be removed for maximizing the operating space. The deck is constructed of steel treadplate for strength and better traction.

MODEL NUMBER	PLATFORM SIZE (W x L)	LOWERED HEIGHT	RAISED HEIGHT	CAPACITY (POUNDS)	OPERATION	NET WT. (POUNDS)	LIST PRICE EACH
POS-3636	36" x 36"	3"	19"	500	HAND CRANK	193	\$764.00
POS-3648	36" x 48"	3"	19"	500	HAND CRANK	220	846.00
POS-3672	36" x 72"	3"	19"	500	HAND CRANK	283	943.00

ELECTRIC/HYDRAULIC OPERATION, model POS-EH, \$420.00 LIST

DC-20/FC-70



## Add-A-Levels

Raise workers to an optimum ergonomic height. Constructed from a heavy-density polyethylene resin which is 100% recycled. The flow-through grid design permits liquids and small scrap to drain away. Also good for use as storage shelf to keep products off wet floors. The stack kit allows two units to be stacked and locked together. The connector kit allows you to connect units side by side. Contact factory for optional ergo-matting.

MODEL NUMBER	WIDTH	LENGTH	HEIGHT	CAPACITY (POUNDS)	NET WT. (POUNDS)	LIST PRICE EACH
P-2436-2.625	24"	36"	2-5/8"	250	13	\$49.00
P-2436-5.250	24"	36"	5-1/4"	250	26	97.00
P-2436-7.875	24"	36"	7-1/8"	250	38	146.00
P-2466-2.625	24"	66"	2-5/8"	250	24	\$90.00
P-2466-5.250	24"	66"	5-1/4"	250	48	181.00
P-2466-7.875	24"	66"	7-1/8"	250	70	271.00

STACK KIT, model VRS-4000, \$10.00 LIST / PACK OF FOUR  
CONNECTOR KIT, model VRC-3000, \$6.00 LIST / PACK OF FOUR

DC-25/FC-100

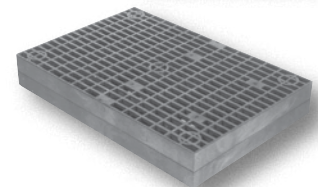
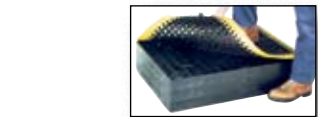

HOW TO ASSEMBLE





COMFORT KING MATTING

## Ergonomic Matting

Provide your workers the comfort cushioning they deserve while standing long hours at a time. These mats are ideal for use at industrial workstations, retail stores, restaurants, and offices. Three different styles to choose from.

MODEL NUMBER	DESCRIPTION	SIZE (W x L)	THICKNESS	NET WT. (POUNDS)	LIST PRICE EACH
ITMAT-23	INDUSTRIAL TREADPLATE	2' x 3'	9/16"	6	\$37.00
ITMAT-35	INDUSTRIAL TREADPLATE	3' x 5'	9/16"	15	90.00
ITMAT-312	INDUSTRIAL TREADPLATE	3' x 12'	9/16"	36	212.00
CK-35	COMFORT KING MATTING	3' x 5'	3/8"	14	\$57.00
CK-310	COMFORT KING MATTING	3' x 10'	3/8"	32	112.00
WM-23	WELDING SPARK SAFE MATTING	2' x 3'	1/2"	7	\$43.00
WM-35	WELDING SPARK SAFE MATTING	3' x 5'	1/2"	17	110.00
WM-312	WELDING SPARK SAFE MATTING	3' x 12'	1/2"	42	264.00

DC-20/UPS



SINGLE-PLY MATTING series EAM-S

## Ergo Anti-Fatigue Matting

Unique waffle-pattern ergo matting provides comfort for users that stand all day long. Single-ply matting is designed for occasional use. Double-ply matting is designed for heavy-duty use including wheeled cart traffic. Many different colors to choose from. Pricing is noted for maximum width of 48". Available in roll lengths up to 50 feet. For special widths greater than 48" contact factory.

MODEL NUMBER	100% RECYCLED MATERIAL	NET WT. (POUNDS)	LIST PRICE EACH
EAM - S - (WIDTH") - (LENGTH") - (COLOR)	SINGLE-PLY MATTING	1.05 LBS./FT <sup>2</sup>	\$8.00/FT <sup>2</sup>
EAM - D - (WIDTH") - (LENGTH") - (COLOR)	DOUBLE-PLY MATTING	1.50 LBS./FT <sup>2</sup>	15.00/FT <sup>2</sup>

MAT COLORS - BLACK, BLUE, BROWN, GRAY, GREEN, ORANGE, RED, TAN, WHITE, YELLOW

DC-25/UPS/FC-100



model WSS-60



model WLPS-2

## Assembly Chairs

High quality durable seating is ideal for production lines, workstations, and industrial/commercial environments. Pneumatic seat height adjustment. Easy to clean seats. The ergonomic style of model WSS-60 features a five foot pad design and a stand with tilt adjustment. The worker stool, model WLPS-2, has a soft foamed polyurethane seat with a five foot pad base design.

MODEL NUMBER	OVERALL SIZE	SEAT HEIGHT RANGE	NET WT. (POUNDS)	LIST PRICE EACH
WSS-60	12½" across	21" to 31"	20	\$145.00
WLPS-2	13½" across	15" to 20"	15	95.00

DC-25/UPS/FC-100



## Ergonomic Office Chairs

Designed with comfort in mind, these well engineered ergonomic chairs provide adjustable height and tilt to contour to the user's body. Gas cylinder operates height adjustment. Constructed of padded foam seat and back with top quality protective cloth covering. The wheel base gives the user the feeling of stability, while providing the maneuverability to get around.

MODEL NUMBER	DESCRIPTION	OVERALL SIZE (W x D x H)	SEAT HEIGHT RANGE	NET WT. (POUNDS)	LIST PRICE EACH
EOC-50	SUPERIOR OFFICE CHAIR	25" x 20½"	17" x 22¾"	65	\$149.00

DC-25/UPS/FC-100



## Massage & Heat Cushion

Unique product design to provide operator massage and heat for better comfort during long sitting periods. Includes 12V cigarette plug, home adapter, and fork truck adapter for use in fork trucks, cars, and office chairs. LCD hand held control provides nice visual for user to recognize different massage and heat settings. Automatic shut-off times of 10, 20 and 30 minutes. Adjustable intensity with eight modes for different massage settings. Cushion is attached to seat with elastic straps.

MODEL NUMBER	SEAT SIZE (W x L)	BACK SIZE (W x H)	MASSAGE	HEATER	NET WT. (POUNDS)	LIST PRICE EACH
CUSH-M	20" x 18"	20" x 29"	YES	NO	5	\$115.00
CUSH-M-H	20" x 18"	20" x 29"	YES	YES	5	126.00

DC-25/UPS

## Ergonomic Worker Seats

From a low crouch to a standing position, the seat height of the CPRO-200 and CPRO-600 can be adjusted in 2" increments by removing the seat and hooking it to the horizontal bars located on the chair frame. These units have four rubber "shocks" under the seat base that allow the seat to tilt forward, left, and right so it can accommodate your body movements. The front tilted position of the seat helps the user maintain the natural posture position of the spine.

The portable work chair, model CPRO-800LP, is not only convenient but easy to use. Simply unfold the rear legs and slide the contoured padded seat to the desired ergonomic height. The infinite adjustment guarantees the optimum work posture. Folds up to a 4" profile for easy portability and storage.

48 Hours  
to Ship



MODEL NUMBER	BASE SIZE (W x D)	SEAT SIZE (W x D)	SEAT HEIGHT RANGE	CAPACITY (POUNDS)	NET WT. (POUNDS)	LIST PRICE EACH
CPRO-200 <sup>®</sup>	14" x 21"	14" x 9"	13" to 26"	400	12	\$148.00
CPRO-600 <sup>®</sup>	14" x 21"	14" x 9"	13" to 34"	400	18	165.00
CPRO-800LP <sup>®</sup>	13" x 20"	13½" x 10"	18" to 33"	300	20	113.00

DC-40/UPS/FC-100

## Desk Mover

Move fully loaded desks without removing drawers and files. To use: position the 31½" wide by 16" deep platform under desk pedestals and depress handle to raise desk and engage safety latch. Steel lift platform and removable handle have a mar and skid resistant vinyl coating to protect the desk. Elevated desk moves easily with or without handle on 3" swivel rubber casters.

MODEL NUMBER	DESCRIPTION	LOWERED HEIGHT	RAISED HEIGHT	CAPACITY (POUNDS)	NET WT. (POUNDS)	LIST PRICE EACH
DESK-M	VINYL COVERED MOVER	4¾"	10¼"	600	45	\$172.00

DC-25/UPS/FC-70



## Fork Truck Seats and Accessories

Ergonomic and comfortable seat design helps provide optimum body support for individual operators. Replace worn or broken fork truck seats with our easy to install universal mounting design. Standard features include: ergonomic seat design, waterfall front on LTSD series, vinyl or cloth material, low profile design, safety seat switch, storage pockets, seat back angle adjustment 8°, adjustable lumbar support, and retractable safety belt.

**Ergo-Turn System** - Smooth pivoting motion enables driver to turn seat 30° left or right of center position. Swivel system can be incorporated with air suspension system for total driver ergonomics.

**Air Suspension System** - Minimizes harmful vibration to fork truck driver. Reduces fatigue and back pain.

**Seat Safety Switch** - Prevents fork truck from operating when an operator is not sitting on the seat.

**Chrome Hip Restraints** - Used in place of arm rests to stabilize and secure the operator in the fork truck seat.

**Flip Up Arm Rest** - Flip up arm rests are moveable to allow easy access on and off fork truck.



LTSD-V with seat belt

LTS-V with seat belt

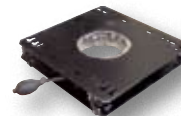

LTS-PN



LTS-ET



LTS-HR



LTS-SSS



LTS-FTSB



LTS-AR

MODEL NUMBER	DESCRIPTION	NET WT. (POUNDS)	LIST PRICE EACH
LTSD-V	VINYL FORK TRUCK SEAT WITH SEAT BELT	50	\$142.00
LTSD-C	CLOTH FORK TRUCK SEAT WITH SEAT BELT	49	142.00
LTS-V	VINYL FORK TRUCK SEAT WITH SEAT BELT	40	\$98.00
LTS-C	CLOTH FORK TRUCK SEAT WITH SEAT BELT	39	98.00

### ACCESSORIES FOR BOTH THE LTSD and LTS

LTS-ET	SWIVEL PLATFORM WITH 30° LEFT/RIGHT	22	\$108.00
LTS-PN	AIR SUSPENSION SYSTEM	29	84.00
LTS-SSS	SEAT SAFETY SWITCH (REPLACEMENT)	2	20.00
LTS-HR	CHROME PLATED HIP RESTRAINTS	4	26.00
LTS-AR	FLIP UP STYLE ARM RESTS	6	32.00
LTS-FTSB	FORK TRUCK SAFETY BELT (REPLACEMENT)	5	36.00

DC-30/FC-125+



BACK-MAX



BACK-COMBO

## Back Support Cushions

There is more stress placed on the lower back than on any other part of the body. Provides support for the lower back to relieve and prevent back pain and fatigue. The S-shaped frame comfortably conforms to the natural S-curve of the spine to guide the back into correct alignment and promote proper sitting posture. Lightweight and portable. Designed for use in any seat; in the office, vehicle, fork truck, or at home. Attaches with hook and loop type fasteners. All Back Support Cushions are black in color.

MODEL NUMBER	DESCRIPTION	OVERALL SIZE (W x D x H)	NET WT. (POUNDS)	LIST PRICE EACH	PRICE FOR 2 OR MORE
BACK-MAX	DELUXE	19" x 8" x 22"	4½	\$41.80	\$39.90
BACK-COMBO	COMBINATION	19" x 8" x 22"	6	48.80	44.90

DC-25/UPS•

MANUAL  
HAND PUMP  
model FORK-JAIR POWERED  
model AIR-J

## Fork Truck Jacks

### Manual Hydraulic Fork Truck Jack

Designed to raise your fork truck for maintenance. Features high-quality seals, chrome plated internal components, and rugged steel construction. Maximum lift of 16" provides room needed to perform a variety of repairs. Manually raised by hand pump lever. Removable handle and compact size makes it easy to maneuver and transport. Includes two jack stands with holding pins for adjustable heights.

### Air Powered Fork Truck Jack

Air-assist motor quickly raises saddle to lift point and then lifts load to desired height. Air powered for quick and easy operation. Uses standard coupler hook-up to a shop air compressor with air regulator control lever handle. Pressure relief valve is located on top of handle for metered control and load height adjustment.

MODEL NUMBER	DESCRIPTION	SERVICE RANGE	CAPACITY (POUNDS)	NET WT. (POUNDS)	LIST PRICE EACH
FORK-J	HYDRAULIC	2¼" to 16"	8,000	98	\$328.00
AIR-J	AIR	8¼" to 18¼"	44,000	131	488.00

DC-25/UPS/FC-70

model H-4  
4 TONmodel H-10  
10 TON

## Heavy-Duty Power Pack (hydraulic maintenance sets)

Hand operated hydraulic maintenance set enables the user to safely and conveniently push, pull, spread, and bend to accomplish daily maintenance tasks. The 4 ton kit comes in a handy storage/carrying case. The 10 ton kit comes in a roller case.

MODEL NUMBER	CASE SIZE (W x L x H)	NUMBER OF PIECES	CAPACITY	NET WT. (POUNDS)	LIST PRICE EACH
H-4	23" x 13" x 7"	15	4 TONS	40	\$207.00
H-10	36" x 15" x 7"	16	10 TONS	75	248.00

DC-25/UPS/FC-85

## Opti-Benches (mechanical adjustable-height work table)

An ergonomic work station featuring a variable height working surface for accommodating different sized workers. This work station utilizes a manual hand crank that will easily raise or lower the working surface. A handy storage shelf is located underneath the working surface. Steel construction. Painted finish.

MODEL NUMBER	PLATFORM SIZE (W x L)	SERVICE RANGE	CAPACITY (POUNDS)	NET WT. (POUNDS)	LIST PRICE EACH
<b>HAND CRANK, MECHANICAL</b>					
ERG-3048-M	30" x 48"	30" to 46"	500	550	\$1,289.00
ERG-3060-M	30" x 60"	30" to 46"	500	616	1,357.00
ERG-3660-M	36" x 60"	30" to 46"	500	715	1,399.00
ERG-3672-M	36" x 72"	30" to 46"	500	781	1,483.00
<b>HAND CRANK, HYDRAULIC</b>					
ERG-3048-H	30" x 48"	30" to 46"	500	550	\$1,289.00
ERG-3060-H	30" x 60"	30" to 46"	500	616	1,357.00
ERG-3660-H	36" x 60"	30" to 46"	500	715	1,399.00
ERG-3672-H	36" x 72"	30" to 46"	500	781	1,483.00
<b>ELECTRIC HYDRAULIC, 110V Power</b>					
ERG-3048-EH	30" x 48"	30" to 46"	500	601	\$1,731.00
ERG-3060-EH	30" x 60"	30" to 46"	500	635	1,800.00
ERG-3660-EH	36" x 60"	30" to 46"	500	737	1,843.00
ERG-3672-EH	36" x 72"	30" to 46"	500	795	1,927.00

DC-20/FC-70





## Electric Adjustable-Height Work Benches

Soft start and stop prevents jarring and provides smooth and even height adjustment. Increase productivity while decreasing fatigue and trauma associated with uncomfortable work positions. Hand pendant control with raise and lower buttons on coil cord and hideaway slide in tray. 115V, 1 phase power supply standard. Extremely sturdy construction with programmable controller allows for three preset heights or for infinite control up and down range with push buttons.



model EAH-3672-MT  
Maple Top Included



PUSH BUTTON SLIDE  
OUT CONTROL PANEL



model EAH-2465

MODEL NUMBER	DESCRIPTION	PLATFORM SIZE (W x L)	SERVICE RANGE	CAPACITY (POUNDS)	NET WT. (POUNDS)	LIST PRICE EACH
EAH-3672-MT	MAPLE TOP	36" x 72"	28" to 45½"	750	309	\$1,709.00
EAH-2465	FRAME ONLY	24" x 65"	26½" to 44"	750	204	1,430.00

DC-20/FC-70

## Linear Actuated Adjustable-Height Work Bench

Increase productivity by allowing the body to reposition to a more comfortable position. The Linear Actuated Adjustable-Height Table allows anyone, regardless of their height, to easily use the table as a workstation or desk. Cantilever design optimizes foot, knee, and leg room. The 36" wide x 36" deep platform is large enough for small parts assembly and will hold up to 500 pounds evenly distributed. A hand-held raise and lower control is attached to the understructure of the table; no more misplacing the remote. Durable hardwood platform standard.

MODEL NUMBER	PLATFORM SIZE (W x L)	SERVICE RANGE	CAPACITY (POUNDS)	OVERALL FRAME SIZE (W x L)	NET WT. (POUNDS)	LIST PRICE EACH
LAW-3636	36" x 36"	30" to 45"	500	36" x 36"	210	\$1,177.00

DC-20/FC-70



## Manual Adjustable Ergonomic Work Benches

Raise material to an ergonomic working height with the Manual Adjustable Ergonomic Work Bench. A fold away hand crank is located directly under the platform for easy raising and lowering. Hydraulic system will raise platform evenly. Rugged steel understructure.

MODEL NUMBER	PLATFORM SIZE (W x L)	SERVICE RANGE	CAPACITY (POUNDS)	NET WT. (POUNDS)	LIST PRICE EACH
EWB-6030	60" x 30"	32" to 46"	750	316	\$965.00
EWB-7236	72" x 36"	32" to 46"	750	339	992.00

DC-20/FC-70



## Synchronized Lift Systems

This unique system may be attached to your equipment to allow for quick and easy height adjustment. It provides for completely synchronized lifting of all four legs at the same time, regardless of weight distribution. Electric/hydraulic operation with single or three phase power available (specify when ordering). Includes four lifting legs with flexible hydraulic hose and quick connectors, slave-style manifold block, electric motor, and hand control. Each lifting leg includes a bolt-on mounting plate (hardware not included). The easy to install components are shipped ready to use. Steel construction.

MODEL NUMBER	DESCRIPTION	CAPACITY (POUNDS)	STROKE	NET WT. (LBS.)	LIST PRICE EACH
SYNC-3	(4) RETROFIT LEGS, PUMP & MANIFOLD	3,000	12"	400	\$4,240.00
SYNC-6	(4) RETROFIT LEGS, PUMP & MANIFOLD	6,000	12"	450	6,180.00

DC-20/FC-70

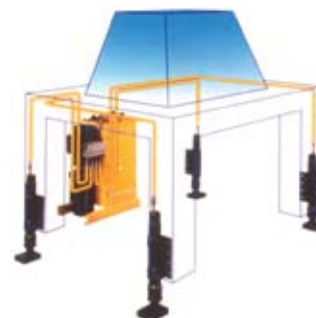

## Plastic Floor Grid

Ideal for storing product at an elevated height above cold and damp floors. Alternatively used as an ergonomic work surface to provide an anti-fatigue worker friendly environment. Snap together, abrasion resistant "GRID" sections are ideal for wet floors such as paint booths, car washes, or general work areas. Lightweight units are only 2 pounds per section. Easy to attach, no hardware necessary. Sold 15 per box.

MODEL NUMBER	OVERALL SIZE (W x L x H)	CAPACITY (POUNDS)	QUANTITY PER BOX	NET WT. PER BOX	LIST PRICE PER BOX
F-GRID	11.8" x 23.6" x 1"	1,100	15	30 LBS.	\$81.00

DC-25/FC-250

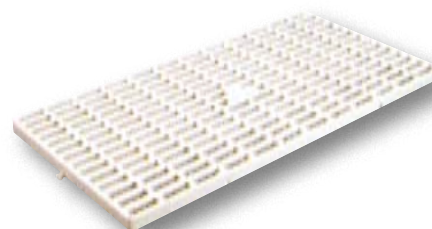

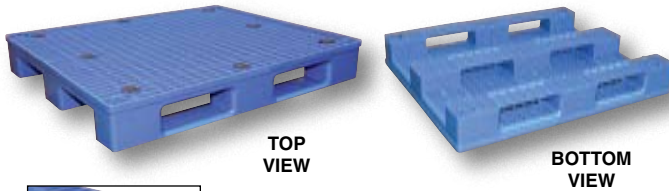

TOP VIEW

BOTTOM VIEW



NON-SKID GROMMET

### Plastic Pallet/Skid

This innovative design unites two essential product features; capacity and versatility. Pallet/Skid entry provides 4-way entry, 2-way by pallet truck and 4-way by a fork truck. The uniform supported capacity is 4,000 pounds. Features anti-slide grommets which prevent the pallets from sliding off the forks and each other during transit.

MODEL NUMBER	UNIFORM SUPPORTED CAPACITY (LBS.)	OVERALL SIZE (W x L x H)	FORK OPENING (W x H)	SKID OPENING (W x H)	NET WT. (POUNDS)	LIST PRICE EACH
PLPS-4840	4,000	39½" x 47¼" x 6"	11¾" x 3¼"	10½" x 3¾"	44	\$83.00

DC-25/FC-70/100

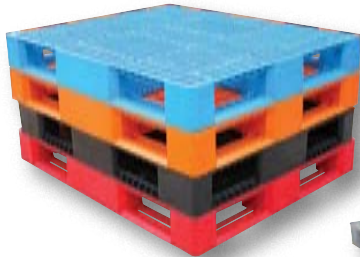

series PLP2  
AVAILABLE IN BLUE  
ORANGE, BLACK AND RED



PLPG-4848

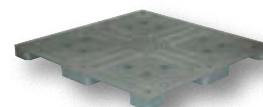

PLPS-4848

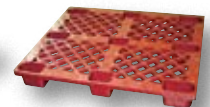

SKID-20

### Plastic Pallets and Skids



Stackable for efficient storage. Made of virgin polyethylene for longer life. Pallets are maintenance free and safer to handle than wooden pallets. Feature four-way entry. Serrated deck with holes for drainage. Plastic pallets are ideal for export, pharmaceutical, medical, and food applications. No steel inserts - not for use in unsupported pallet rack, except for model PLPR-4840.

MODEL NUMBER	DESCRIPTION	UNIFORM SUPPORTED CAPACITY (LBS.)	OVERALL SIZE (W x L x H)	FORK OPENINGS (W x H)	NET WT. (POUNDS)	LIST PRICE EACH
PLP2-4840-BLUE	BLUE PALLET	4,000	48" x 40" x 6"	9¾" x 4"	38	\$88.00
PLP2-4840-ORANGE <sup>Ⓞ</sup>	ORANGE PALLET	4,000	48" x 40" x 6"	9¾" x 4"	38	88.00
PLP2-4840-BLACK	BLACK PALLET	4,000	48" x 40" x 6"	9¾" x 4"	38	88.00
PLP2-4840-RED	RED PALLET	4,000	48" x 40" x 6"	9¾" x 4"	38	88.00
PLPG-4848 <sup>Ⓞ</sup>	GREY PALLET	3,500	48" x 48" x 6"	12½" x 3½"	65	148.00
PLPG-4848-HD* <sup>Ⓞ</sup>	GREY PALLET	4,500	48" x 48" x 6"	12½" x 3½"	72	153.00
PLPB-4840* <sup>†</sup> **	BLACK PALLET	4,000	48" x 40" x 5½"	8½" x 3½"	38	70.00
PLPR-4840 <sup>†</sup>	GREY RACKABLE PALLET	see below (†)	48" x 40" x 6"	8¾" x 3¼"	55	\$135.00
PLPS-4848 <sup>Ⓞ</sup>	GREY SKID	2,500	48" x 48" x 2¾"	12½" x 2"	36	\$96.00
SKID-20	RED SKID	2,000	39½" x 47¼" x 5½"	12" x 4"	20	41.00

\*NOT PALLET TRUCK USABLE (NOT SHOWN)

DC-25/FC-70/100

\*\*ANTI-SLIDE GROMMETS INCLUDED IN FORK POCKETS AND ON TOP/BOTTOM OF PALLET - PREVENTS PALLET FROM SLIDING DURING TRANSPORTATION

†RACKABLE PALLET - 10,000 LBS. STATIC / 3,700 LBS. DYNAMIC / 2,200 LBS. RACKING CAPACITY (NOT SHOWN)

### Aluminum Pallets

This is the pallet the food and chemical industries have always wanted. Easy to clean with a power washer. Stands up to high-power steam, brushes, or pads. Features a non-skid surface for easy transportation of all products. Durable and re-usable. Heavy-duty welded aluminum construction.

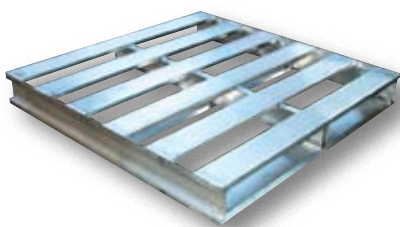

MODEL NUMBER	UNIFORM SUPPORTED CAPACITY (POUNDS)	OVERALL SIZE (W x L x H)	FORK OPENINGS (W x H)	NET WT. (POUNDS)	LIST PRICE EACH
AP-4248	6,000	42" x 48" x 6"	19" x 4-3/8"	40	\$258.00
AP-4848	6,000	48" x 48" x 6"	22" x 4-3/8"	50	276.00

DC-25/FC-70

### Multi-Height Container

Increase flexibility and accessibility with this Multi-Height Container. As the user loads or unloads the height can be increased or decreased. Constructed of polyethylene plastic with steel hinges. Four way pallet increases convenience.

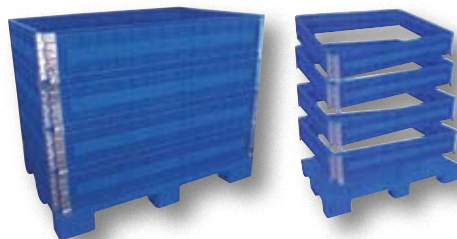

MODEL NUMBER	DESCRIPTION	OUTSIDE DIMENSIONS (W x D x H)	NET WT. (POUNDS)	LIST PRICE EACH
MULTI-C	MULTI-HEIGHT CONTAINER	47¼" x 31½" x 37½"	95	\$289.00

DC-25/FC-70/100

### Folding Container

Requires a minimum of storage space when not in use.

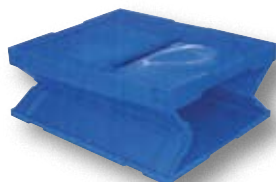

MODEL NUMBER	OUTSIDE DIMENSIONS (W x D x H)	FOLDED HEIGHT	NET WT. (POUNDS)	LIST PRICE EACH
F-CRATE	23½" x 18½" x 12"	3"	8	\$23.90

DC-25/FC-70/100