

INSTALLATION INSTRUCTIONS

MODEL: 30032 / 30035 SIX BIKE DELUXE PARK STAND WITH ACCESSORY BAR

THANK YOU FOR YOUR PURCHASE. We take a **SATISFACTION GUARANTEED** approach to our products and our business, if you are not satisfied in any way, or if we can provide you with assistance or information, PLEASE call us TOLL FREE at 800-346-7332 or e-mail us at contactus@mygearup.com.

The GEAR-UP™ FLOOR STAND with ACCESSORY TOP RACK holds up to six bicycles of any style or shape. The TOP RACK holds helmets, goggles, book bags, and more. Designed and Engineered in the USA, and manufactured to exacting specifications in CHINA.

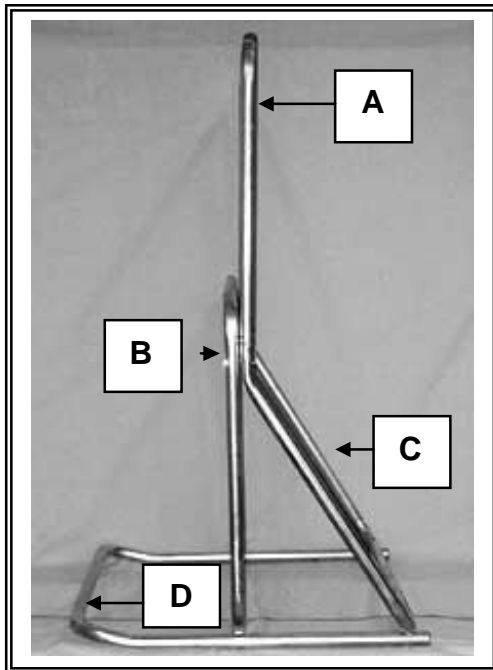

Bill of Material:

A.	30030A	1	ACCESSORY TOP RACK
B.	30030B	1	FLOOR STAND BIKE HOLDER
C.	30030C	1	FLOOR STAND BRACE & ACCESSORY BAR MOUNT
D.	30030D	1	FLOOR STAND BASE
E.	30030E	6	BOLTS
F.	30030F	18	NYLON WASHERS
G.	30030G	6	NUTS

NOTE: WHEN ORDERING REPLACEMENT PARTS, SPECIFY BLACK OR GALVANIZED.

INSTALLATION:

1. We have taken great care to package this product complete and in such a way as to prevent shipping damages. Please examine the contents and report any problems as soon as possible by calling our **TOLL FREE NUMBER 800-346-7332**.
2. Position component "D" as shown in the picture above.
3. Attach Floor Stand Bike Holder to Base. Insert bolt "E" through washer "F" up from bottom of component "D" through second washer "F" through component "B" through third washer "F" through nut "G". **DO NOT COMPLETELY** tighten at this time. Repeat process for opposite side. (**SEE FIG 1 – BOLT ASSEMBLY**).
4. Position component "C" as shown in the picture above.

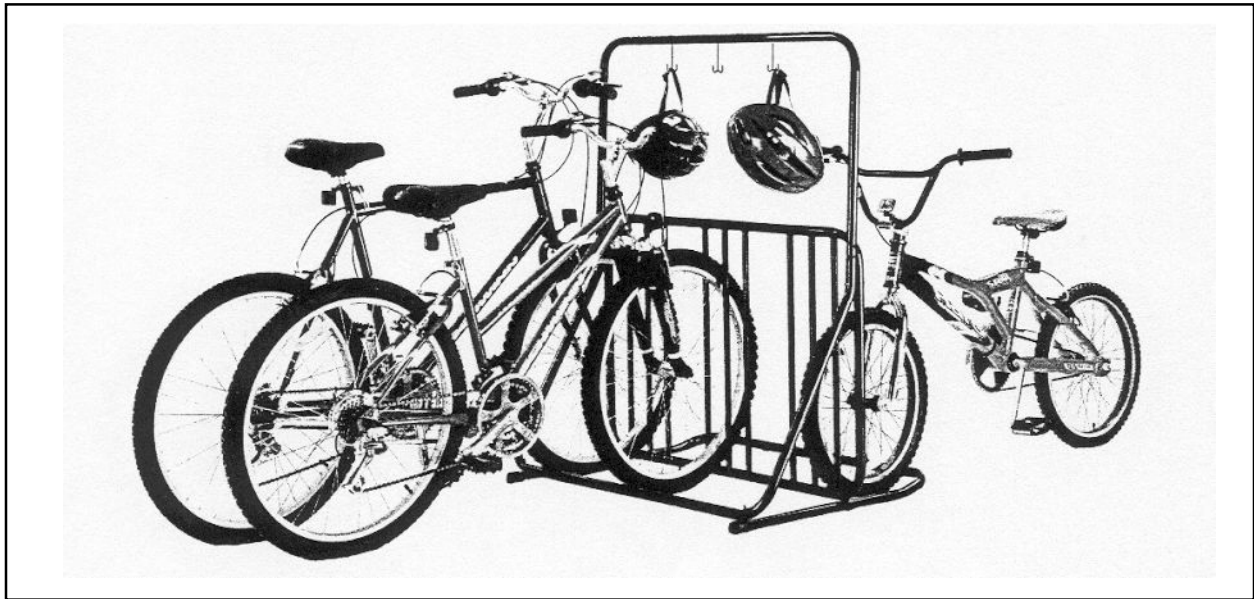

5. Attach Floor Stand Brace to component "D". Insert bolt "E" through washer "F" up through bottom of component "D" through second washer "F" through component "C" through third washer "F" through nut "G". DO NOT COMPLETELY tighten at this time. Repeat process for opposite side. (**SEE FIG 1 – BOLT ASSEMBLY**)
6. Attach Floor Stand Brace to component "B". Insert bolt "E" through washer "F" through component "B" through second washer "F" through component "C" through third washer "F" through nut "G". DO NOT COMPLETELY tighten at this time. Repeat process for opposite side. (**SEE FIG 1 – BOLT ASSEMBLY**)
7. Attach Top Rack to component "C". The Top Rack Accessory slips onto the each end of the Floor Stand Brace.
8. Tighten ALL Hardware after attaching Top Rack Accessory.
9. You are now ready to use your new Bicycle Storage Rack. You can store up to 6 bicycles (3 on the front side & 3 on the back side) as shown in the picture above.

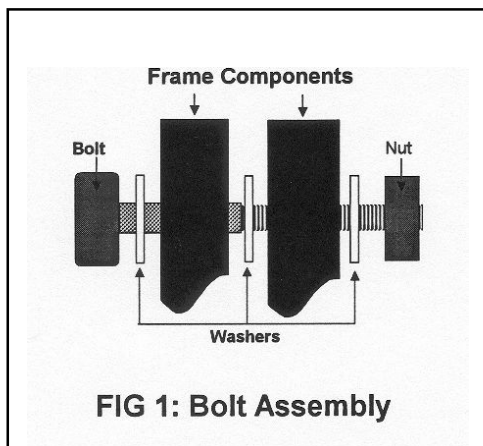

WARNING

DO NOT STEP, CLIMB, OR HANG ON THE STORAGE RACK

DO NOT ALLOW SMALL CHILDREN OR PETS TO PLAY IN, ON, OR AROUND THE STORAGE RACK. IMPROPER INSTALLATION AND/OR USE OF THE STORAGE RACK COULD CAUSE SERIOUS INJURY AND/OR DEATH.

User assumes total responsibility for the proper installation and use of this product. GearUp Inc. will not be held liable for damages or injuries resulting from the installation and/or use of this product. If the installer or user is unsure of the requirements described herein, it is his/her responsibility to seek adequate professional assistance or contact our customer care center at 800-346-7332. **REMEMBER** – stored items can fall resulting in injuries and/or property damage when not properly installed or used.

THANK YOU again for your purchase. We have worked hard to make sure the product you purchased is of top quality and that all parts and necessary instructions have been included. If we have overlooked anything, or if we can be of assistance, help walk you through installation, or offer tips on how to use our product, **PLEASE** give us a call on our **Toll Free Customer Hotline 800-346-7332. YOUR SATISFACTION IS OUR TOP PRIORITY.**

Visit us at our web site www.mygearup.com for other storage solutions and special offerings.