



Oregon Roof Consulting and Inspection

No-Nonsense Roofing Advice for Property Owners: Affordable ~ Thorough ~ Versatile ~ Capable

Serving the Portland Metro area and all of Oregon: (503) 654-4612

Oregon CCB: 199121 ~ WA Lic: OREGORC871MR

PO Box 220190, Milwaukie, OR 97222

Resume' ~ Track Record ~ Experience ~ Qualifications ~ History

Please note : I have 44 years of legitimate verifiable experience as a laborer / grunt / gopher for my brother's roofing business in the 60's, the better part of 3 decades as a roofing contractor, 6 years as an estimator / project manager for 2 large roofing companies and am now nearing the end of my 10th year as the owner / operator of Oregon Roof Consulting and Inspection. I have personally installed over 1,000 roofs and have done at least 14,000 roofing estimates back in the roofing days. Oregon Roof Consulting has participated in 5 courtroom hearings and 16 arbitration hearings in Oregon and Washington and 19 on site CCB mediation meetings in Oregon - all as an expert witness, so, we are somewhat familiar with the roofing trade.

I have done work for but not limited to : Homeowners; Businesses and corporations of all sizes; Insurance companies; Banks; Churches; Relocation companies; Roofing contractors; Investment groups; HOA's; Apartment complexes of all sizes; The State of Oregon; Multiple school districts including West Linn; David Douglas; and every elementary, middle, and high school in both Hood River and Wasco (The Dalles) counties; United States Coast Guard in Astoria; etc. I have done jobs all over Oregon and Washington; All over the San Francisco Bay Area including San Francisco, Oakland, Napa, Richmond, Alameda, Fremont, Pleasanton, Berkeley, Fresno, Sacramento and Reno Nevada. We have also helped with two shingle roofing projects on the remote South Pacific island of Rarotonga (Cook Islands). This is all on my website. See www.oregonroofconsulting.com

Thank you,

Owner of Oregon Roof Consulting & Inspection

Oregon Roof Consulting and Inspection No-Nonsense Roofing Advice for Property Owners



- Affordable ~ Thorough ~ Versatile ~ Capable
- Roofing in Oregon Since 1973
- Project Management & Monitoring
- Inspections ~ Certifications ~ Owner Advocacy

www.oregonroofconsulting.com

Phone: (503) 654-4612 Cell: (503) 952-6479

Email: joe@oregonroofconsulting.com

PO 220190 Milwaukie, OR 97222

CCB 199121 ~ WA OREGORC871MR

Joe Sardotz, Owner Operator



Oregon Roof Consulting and Inspection

No-Nonsense Roofing Advice for Property Owners: Affordable ~ Thorough ~ Versatile ~ Capable

Serving the Portland Metro area and all of Oregon: (503) 654-4612

Oregon CCB: 199121 ~ WA Lic: OREGORC871MR

PO Box 220190, Milwaukie, OR 97222

Roof Inspection for :

Job Address : ~ Bend, Oregon 97702

I inspected this roof on July 31st 2023. I met the owner, looked in the attic and got on the roof. The roof is a new GAF 'Timberline' 30 year factory warranted asphalt laminated shingle. One layer over plywood. Separate photo emails will be sent. Each photo email will be numbered to correspond to the numbered items on the summary report. The following items should be noted :

1. There is no ice barrier / ice and water shield on this roof. I checked all eaves. Underlayment is 15lb felt covered by a synthetic underlayment. The code and city of Bend both **require** ice and water shield. The homeowner confirmed this with a Bend building inspector. **See attached code page.
2. There are blown through nails at all overhangs. The industry standard is to use a shorter nail here and to add 2 additional nails per full shingle to compensate for the minimal deck penetration.
3. Some shingles have brown 'bald spots'. Forward these photos to GAF.
4. There is a very crooked valley in front. Valleys should be straight. They have a tool called a 'chalk line / box' which is very helpful in creating straight valleys.
5. The ridge vent opening is way too small. There must be a 3/4" cut on both sides of the apex / peak.
6. The nails used to fasten the shingles are too high and a majority are over driven. Laminated shingles are 2 pieces: A 'blank' and a 'sawtooth'. Where they overlap has a factory embossed line or lines which is the nailing 'line' or 'zone'. This is the strongest part of the shingle and is where the nails must go. Most nails I saw were above the nailing line and most of those are also over driven. Nails must be driven straight with heads flush with the shingle surface.
7. The ridge shingle nails are in the sealant. All manufacturers say do not nail in the sealant as that lessens the holding power of the sealant. Many ridge shingle nails are over driven.
8. Some of the valley shingles do not go all the way to the valley. Some rows are incomplete. See yellow markings in photos.
9. On the small kickout dormer on the side of the hoese there is a mangled rake edge flashing. Looks terrible. See photos. Plus, on such a short run the industry standard is to use 1 piece not 2 pieces on such a short run.

Conclusion : There is a code. Certain things must be done a certain way. This roof was not professionally installed. Plus, it is my understanding that the contractor who installed this roof had an expired license. If that is true then those folks had no business on this property. At some point the word 'integrity' comes in to play.

It is any Contractor's responsibility, obligation, and requirement to 1) Know how a roof system should be installed. 2) Install that roof system correctly.

**** The Oregon Residential Specialty Code R102.7.1 : 'Additions, alterations or repairs (excluding ordinary repairs) to any structure shall conform to the requirements for a new structure without requiring an existing structure to comply with all of the requirements of this code, unless otherwise stated. Additions, alterations or repairs **shall not cause an existing structure to become unsafe or adversely affect the performance of the building.....'** R905.1 : 'Roof coverings shall be applied in accordance with the applicable provisions of this section and manufacturers installation instructions'. R903.1 : ' Roof Assemblies shall be designed and installed in accordance with this code and the approved manufacturers instructions such that **the roof assembly shall serve to protect the building or structure** '. R105.2 : 'Exemption from permit requirements of this code shall not be deemed to grant authorization for any work to be done in a manner in violation of the provisions of this code or any other laws or ordinances of this jurisdiction'. **** A permit may or may not be required in your area. To inquire call local building officials.****

Thank you,



Owner of Oregon Roof Consulting & Inspection

****This document carries no warranty or guarantee. It is an opinion based on industry standards, manufacturers specifications, local codes and my experience****

Oregon Roof Consulting and Inspection
No-Nonsense Roofing Advice for Property Owners



- Affordable ~ Thorough ~ Versatile ~ Capable
- Roofing in Oregon Since 1973
- Project Management & Monitoring
- Inspections ~ Certifications ~ Owner Advocacy

www.oregonroofconsulting.com
Phone: (503) 654-4612 Cell: (503) 952-6479
Email: joe@oregonroofconsulting.com
PO 220190 Milwaukie, OR 97222
CCB 199121 ~ WA OREGORC871MR
Joe Sardotz, Owner Operator

Underlayment shall not interfere with the ability of the shingles to seal. End laps shall be offset by 6 feet (1829 mm).

ITEM #1 ON ROOF SUMMARY

R905.2.7.1 Ice barrier. In areas where the average daily temperature in January is 25°F (-4°C) or less or where there has been a history of ice forming along the eaves causing a backup of water, an ice barrier that consists of a least two layers of underlayment cemented together or of a self-adhering polymer modified bitumen sheet, shall be used in lieu of normal underlayment and extend from the lowest edges of all roof surfaces to a point at least 24 inches (610 mm) inside the exterior wall line of the building.

> OREGON RESIDENTIAL SPECIACITY CODE <

Exception: Detached accessory structures that contain no conditioned floor area.

R905.2.7.2 Underlayment and high wind. Underlayment applied in areas subject to high winds [above 110 mph (49 m/s) per Figure R301.2(4)] shall be applied with orro-

NAILING INSTRUCTIONS / HAND SEALING
INSTRUCCIONES DE CLAVADURA / SELLADO A MANO
INSTRUCTIONS DE CLOUAGE / SCHELEMENT À LA MAIN

ITEM #6 ON
 ROOF SURMARY

These shingles **MUST** be nailed a nominal 6" (152mm) from bottom of shingle, above the cut-outs, as shown. Nails must not be exposed. To hand seal and to insure immediate sealing, apply 4 quarter-sized dabs of shingle tab adhesive on the back of the shingle 1" (25mm) and 13" (330mm) in from each side and 1" (25mm) up from bottom of the shingle. Press shingle firmly into the adhesive. **CAUTION:** Apply **ONLY** a thin uniform layer of asphalt plastic cement less than 1/8" (3mm) thick. Excess amounts can cause blistering of the shingles and may soften the asphalt in underlayments and leak barriers, resulting in the asphalt dripping and staining.

Estas tejas **DEBEN** clavarse un nominal 6" (152mm) de la parte inferior de la teja, por encima de los recortes, como se muestra. Clavos no deben ser expuestos. Para entregar sello y para asegurar sellado inmediato, aplica 4 toques suaves cuarto-calibrados de adhesivo de etiqueta de tablilla en la espalda de la tablilla 1" (25 Mm) y 13" (330 Mm) en de cada lado y 1" (25 Mm) arriba de fondo de la tablilla. Presione firmemente sobre el adhesivo **ATENCIÓN:** Aplique solamente una capa fina y uniforme de cemento asfáltico de plástico menos de 1/8"(3mm) de espesor. Cantidades excesivas puede causar ampollas de la culebrilla y puede ablandar el asfalto en las capas de base y las barreras de fugas, lo que resulta en el asfalto de goteo y las manchas.

Ces bardeaux doivent être cloués à une distance nominale de 152mm (6po) de leur base, au-dessus des portions découpées, comme indiqué. Les clous ne doivent pas être exposés. Pour transmettre le cachet et assurer sceller immédiat, appliquer 4 taches de quart-calibré d'adhésif d'étiquette de bardeau sur le dos du bardeau 1" (25 mm) et 13" (330 mm) en de chaque côté et 1" (25 mm) en haut du fond du bardeau. Pour assurer sceller immédiat, appuyer le bardeau fermement dans l'adhésif. **PRUDENCE :** S'appliquer **SEULEMENT** une couche uniforme mince d'asphalte ciment en plastique moins que 1/8" (3 mm) épais. Les quantités supplémentaires peuvent causer peler des bardeaux et peuvent amollir l'asphalte dans GAF underlayments et les barrières de fuite de GAF, avoir pour résultat l'asphalte qui dégoutte et tacher.

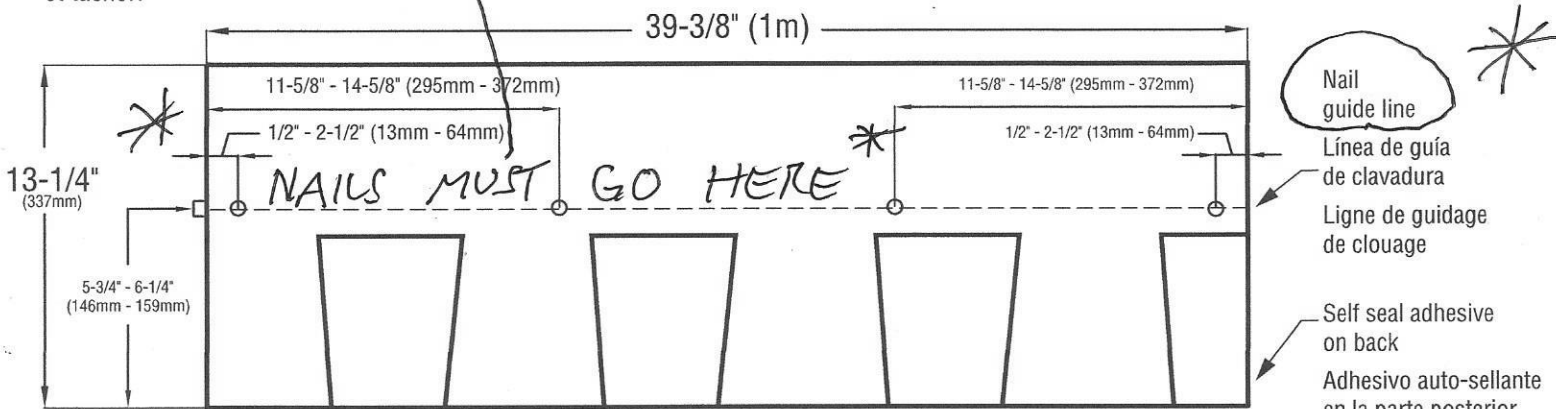

STANDARD NAILING PATTERN - four nails per shingle
ESQUEMA DE CLAVADURA ESTÁNDAR - cuatro clavos por teja
PATRON DE CLOUAGE STANDARD - quatre clous par bardeau

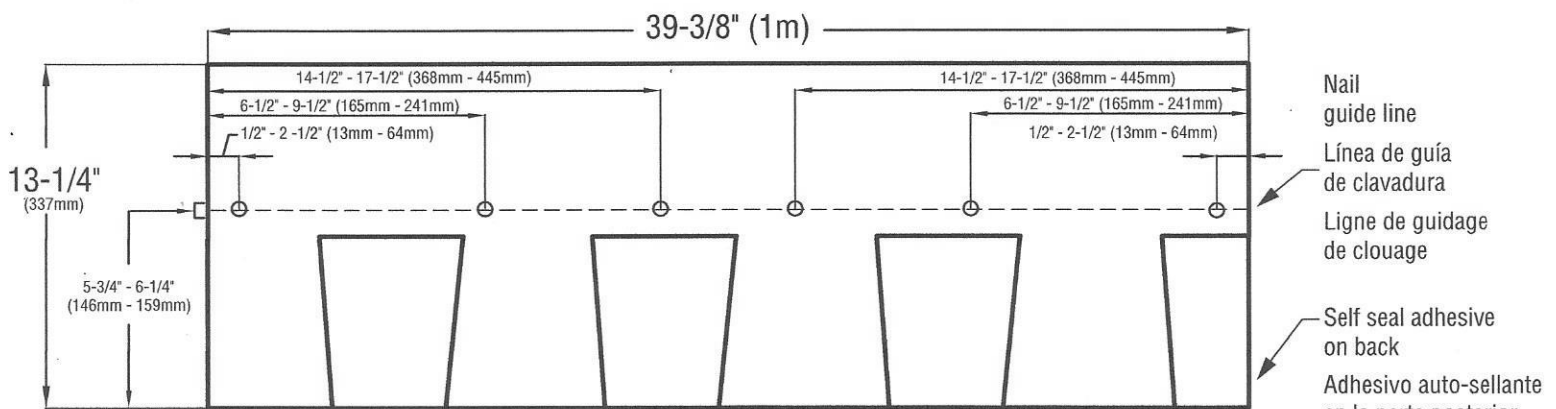

ENHANCED NAILING PATTERN - six nails per shingle*

* required by some local codes and required for enhanced wind coverage on certain products.

See limited warranty for details

MODELO DE CLAVADURA AUMENTADO - seis clavos por teja*

* requerido por algunos códigos locales y requerido para cobertura aumentada contra el viento en ciertos productos.

Garantía limitada See para los detalles

PATRON DE CLOUAGE ACCRU - six clous par bardeau*

* requis par certains codes locaux pour une couverture accrue contre les vents sur certains produits.

Garantie limitée See pour des détails

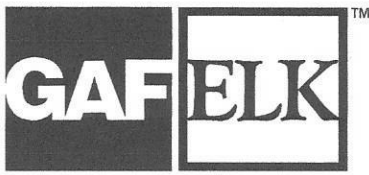

TIMBERLINE PRESTIQUE[®] LIFETIME[®]
HIGH DEFINITION SHINGLES

TIMBERLINE PRESTIQUE[®] 30[®]
HIGH DEFINITION SHINGLES

TIMBERLINE PRESTIQUE[®] 40[®]
HIGH DEFINITION SHINGLES

TIMBERLINE Natural Shadow[®]
SHINGLES

APPLICATION INSTRUCTIONS

English

Note: These shingles MUST be nailed a nominal 5 5/8" (143mm) from bottom of shingles, not in or above self seal, as shown. Nails should remain unexposed.

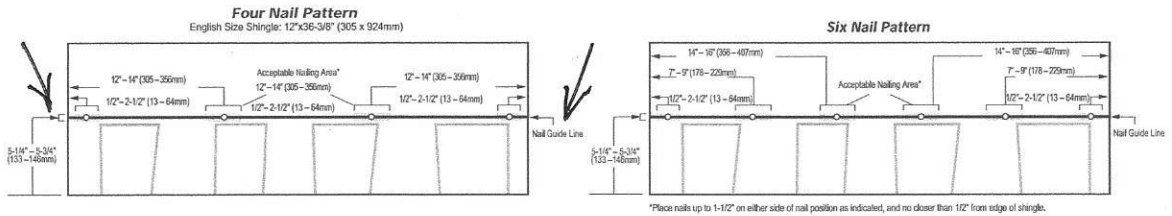

GENERAL INSTRUCTIONS

ITEM #6 ON ROOF SUMMARY

• **ROOF DECKS:** Wood decks must be well-seasoned, supported, and tightly-constructed with maximum 6" (152mm) wide lumber, having adequate nail-holding capacity and a smooth surface. Plywood or OSB decking as recommended by APA-The Engineered Wood Assn. is acceptable. Do not fasten shingles directly to insulation or insulated deck unless authorized in writing by GAF-Elk. Roof decks and existing surfacing material must be dry prior to application of shingles.

• **UNDERLAYMENT:** Underlayment beneath shingles has many benefits, including preventing wind-driven rain from reaching the interior of the building and preventing sap in some wood decking from reacting with asphalt shingles. Underlayment is also required by many code bodies and is required to maintain the UL Class A fire rating. Where an underlayment is to be installed, use a breather-type underlayment such as GAF-Elk Shingle-Mate[®], Leatherback[®] or Deck-Armor[™] underlayment.

• **FASTENERS:** Use only zinc-coated steel or aluminium, 10-12 gauge, barbed, deformed or smooth shank roofing nails with heads 3/8" (10mm) to 7/16" (12mm) in diameter. Fasteners should be long enough to penetrate at least 3/4" (19mm) into wood decks or just through the plywood decks. Fasteners must be driven flush with the surface of the shingle. Overdriving will damage the shingle. Raised fasteners will interfere with the sealing of the shingles and can back out.

• **WIND RESISTANCE/HAND SEALING:** These shingles have a special thermal sealant that firmly bonds the shingles together after application when exposed to sun and warm temperatures. Shingles installed in Fall or Winter may not seal until the following Spring. If shingles are damaged by winds before sealing or are not exposed to adequate surface temperatures, or if the self-sealant gets dirty, the shingles may never seal. Failure to seal under these circumstances results from the nature of self-sealing shingles and is not a manufacturing defect. To insure immediate sealing, apply 4 quarter-sized dabs of shingle tab adhesive on the back of the shingle 1" (25mm) and 13" (330mm) in from each side and 1"

(25mm) up from bottom of the shingle. Press shingle firmly into the adhesive. For maximum wind resistance along rakes, install GAF-Elk Starter Strip Shingles with GAF-Elk Dura-Grip[®] sealant or cement shingles to underlayment and each other in a 4" (102mm) width of asphalt plastic cement. Caution: Apply ONLY a thin uniform layer of asphalt plastic cement less than 1/8" (3mm) thick. Excess amounts can cause blistering of the shingles and may soften the asphalt in certain underlayments, including StormGuard[®], Weather Watch[®] and other GAF-Elk Leak Barriers, resulting in the asphalt flowing, dripping and staining.

• **RELEASE FILM:** The film strips on the back of each shingle are to prevent sticking together of the shingles while in the bundle. Their removal is NOT required during application.

• **MANSARD AND STEEP SLOPE APPLICATIONS:** For roof slopes greater than 21" per foot (1750mm/m), shingle must be hand sealed (DO NOT use on vertical side walls). See "Wind Resistance/Hand Sealing" for the application of adhesive.

• **SHINGLE TAB ADHESIVE:** Use asphalt plastic cement conforming to ASTM D4586 Type I or II.

• **THROUGH VENTILATION:** All roof structures must be provided with through ventilation to prevent entrapment of moisture-laden air behind roof sheathing. Proper ventilation is also necessary to prevent mold growth. Ventilation provisions must at least meet or exceed current F.H.A., H.U.D. or local code minimum requirements. Note: Minimum net free ventilation area of 1 sq. foot per 150 sq. feet (1 sq. meter per 150 sq. meters) of ceiling area is required. When vents are located at the eaves and near the roof's peak (balanced) for maximum air flow, ventilation may be reduced to 1 sq. foot per 300 sq. feet (1 sq. meter per 300 sq. meters).

• **NON-CORRODING METAL DRIP EDGES:** Recommended along rake and eave edges on all decks, especially plywood decks.

• **EXPOSED METAL:** All exposed metal surfaces (flashing, vents, etc.) should be painted with matching GAF-Elk roof accessory paint.