

**CUPERTINO SANITARY DISTRICT
SANITARY BOARD MEETING
WEDNESDAY, DECEMBER 7, 2022**

AGENDA

The meeting will be held at 7:00 p.m. via teleconference [call 1 (866) 899 - 4679 Conference Access Code: 251566821] and anyone interested may also call in. The District Office at 20863 Stevens Creek Blvd, Suite 100, Cupertino is closed.

1. ROLL CALL

2. AB 361

The Board of Directors makes the following findings required by AB 361 in order to continue holding meetings by teleconferencing electronically: (1) the March 4, 2020 Governor's Proclamation of a State of Emergency is still in effect, (2) the California Department of Public Health and the County Health Officer continue to encourage social distancing and strongly recommend that all people wear masks in all indoor public spaces, and (3) due to room capacity limitations, meeting in person would present imminent risks to the health or safety of attendees.

3. PUBLIC COMMENTS

This portion of the meeting is reserved for persons desiring to address the board on any matter not on the agenda. Speakers are limited to three (3) minutes.

All statements requiring a response will be referred to staff for further action. In most cases, state law will prohibit the board from making any decisions with respect to a matter not listed on the agenda.

4. CLOSED SESSION

- A. CONFERENCE WITH LEGAL COUNSEL – EXISTING LITIGATION
in accordance with government code section Paragraph (1) of Subdivision (d) of Section 54956.9, existing litigation. Name of Case: County Sanitation District 2-3, West Valley Sanitation District, Cupertino Sanitary District, Burbank Sanitary District and the City of Milpitas v. The City of San Jose, The City of Santa Clara and Does 1 through 50 inclusive.

5. MINUTES

- A. APPROVAL OF THE REGULAR MEETING MINUTES OF NOVEMBER 16, 2022
- B. APPROVED MINUTES OF OCTOBER 19, 2022

6. CORRESPONDENCE

- A. SANTA CLARA COUNTY CLERK OF THE BOARD – APPOINTMENT OF PATRICK KWOK

**CUPERTINO SANITARY DISTRICT
SANITARY BOARD MEETING
WEDNESDAY, DECEMBER 7, 2022**

- B. COUNTY OF SANTA CLARA OFFICE OF COUNTY ASSESSOR – LUCKY ROAD ANNEXATION NO. 1

7. MEETINGS

- A. TELECONFERENCE MEETING OF THE SAN JOSE/SANTA CLARA TREATMENT PLANT ADVISORY COMMITTEE (TPAC) HELD ON THURSDAY, DECEMBER 8, 2022

8. REPORTS

- A. TELECONFERENCE MEETING OF THE SAN JOSE/SANTA CLARA TREATMENT PLANT TECHNICAL ADVISORY COMMITTEE (TAC) HELD ON MONDAY, DECEMBER 5, 2022
- B. SANTA CLARA COUNTY SPECIAL DISTRICTS ASSOCIATION REGULAR TELECONFERENCE MEETING HELD ON DECEMBER 5, 2022.
- C. CALIFORNIA ALLIANCE FOR SEWER SYSTEM EXCELLENCE (CASSE) ZOOM MEETING HELD ON DECEMBER 7, 2022

9. UNFINISHED BUSINESS

- A. COVID-19 UPDATES

10. NEW BUSINESS

- A. INSTALLER'S AGREEMENT – ALAN ROW
- B. PURCHASE OF ONE NEW 20 KW MULTIQUIP TRAILER-MOUNTED GENERATOR AND REHABILITATION OF COUNTRY CLUB PUMP STATION

11. STAFF REPORT

- A. FUTURE DEVELOPMENT PROJECTS

12. CALENDAR ITEMS

- A. NEXT REGULAR DISTRICT BOARD MEETING IS TO BE HELD ON WEDNESDAY, DECEMBER 21, 2022

13. ADJOURNMENT

CUPERTINO SANITARY DISTRICT BOARD MEETING
WEDNESDAY, NOVEMBER 16, 2022

The Sanitary Board of the Cupertino Sanitary District convened this date at 7:00 p.m. This meeting was conducted via teleconferencing in accordance with AB 361. The District office at 20863 Stevens Creek Blvd, Suite 100, Cupertino was closed.

1. ROLL CALL:

President Bosworth called the meeting to order, and the following proceedings were had to wit: Roll call was taken, with the following members in attendance:

Directors present: Angela S. Chen, Taghi S. Saadati, David A. Doyle, William A. Bosworth and Patrick S. Kwok.

Staff present: District Manager Benjamin Porter, Deputy District Manager Robert Woodhouse, and Counsel Marc Hynes.

District Consultant: Richard K. Tanaka

Public: None

2. AB 361:

The Board of Directors makes the following findings required by AB 361 in order to continue holding meetings by teleconferencing electronically: (1) the March 4, 2020 Governor’s Proclamation of a State of Emergency is still in effect, (2) the County of Santa Clara Health Officer announced on May 10, 2022 that COVID-19 cases are rising again to higher levels than last summer's surge and there is a rise in hospitalizations; she continues to encourage social distancing and advises people wear masks indoors, and (3) due to room capacity limitations, meeting in person would present imminent risks to the health or safety of attendees.

On a motion by President Bosworth, seconded by Director Chen, by a vote of 5-0-0, the Board approved.

3. PUBLIC COMMENTS:

There were none.

4. CLOSED SESSION:

President Bosworth adjourned the regular meeting session and opened the closed session at 7:02 p.m. Manager Porter, and Deputy Manager Woodhouse were excused from the closed session.

- A. Conference with legal counsel – Existing Litigation in accordance with government code section Paragraph (1) of Subdivision (d) of Section 54956.9, existing litigation. Name of Case: County Sanitation District 2-3, West Valley Sanitation District, Cupertino Sanitary District, Burbank Sanitary District, and the City of Milpitas v. The City of San Jose, The City of Santa Clara, and Does 1 through 50 inclusive.

Board action: There was no reportable action.

CUPERTINO SANITARY DISTRICT BOARD MEETING
WEDNESDAY, NOVEMBER 16, 2022

President Bosworth adjourned the closed session at 7:10 p.m. and the regular meeting was called to order. District Manager Porter, and Deputy Manager Woodhouse rejoined the regular meeting.

5. MINUTES & BILLS:

- A. On a motion by Director Chen, seconded by Director Doyle, by a vote of 3-0-0, the minutes of the regular meeting held Wednesday, October 19, 2022, were approved. President Bosworth and Director Kwok abstained, as they were absent from the October 19th meeting.
- B. By consensus, the Minutes of Wednesday, October 5, 2022, are to be Noted & Filed.
- C. The Board reviewed October payable warrants and financial statements. On a motion by Director Saadati, seconded by Director Chen, by a vote of 5-0-0, the financial statements and payment of bills for October were approved as written.
- D. Board members submitted their November timesheets to Manager Porter.

6. CORRESPONDENCE:

There was none.

7. MEETINGS:

- A. Manager Porter and President Bosworth both plan to attend the teleconference meeting of the San Jose/Santa Clara Treatment Plant Technical Committee (TAC) to be held on Monday, December 5, 2022.
- B. Director Kwok plans to attend the teleconference meeting of the San Jose/Santa Clara Treatment Plant Advisory Committee (TPAC) to be held on Thursday, December 8, 2022.

8. REPORTS:

- A. Manager Porter reported on the teleconference meeting of the San Jose/Santa Clara Treatment Plant Technical Committee (TAC) held on Monday, November 7, 2022.
- B. Director Kwok reported on the teleconference meeting of the San Jose/Santa Clara Treatment Plant Advisory Committee (TPAC) held on Thursday, November 10, 2022.
- C. Deputy Manager Woodhouse reported on the CASA Collection Systems Workgroup held November 1, 9, and 16, 2022.

9. UNFINISHED BUSINESS:

- A. District Manager Porter reported on the Covid-19 updates.
- B. The Board reviewed the draft annual report. On a motion by Director Saadati, seconded by Director Kwok, by a vote of 5-0-0, the Board approved the annual report.

CUPERTINO SANITARY DISTRICT BOARD MEETING
WEDNESDAY, NOVEMBER 16, 2022

- C. The Board discussed renewal of the Special District Leadership Foundations Transparency Certificate of Excellence. On a motion by Director Doyle, seconded by Director Saadati, by a vote of 5-0-0, the Board directed Staff to submit application for renewal.

Senior Engineer Vani Kathula joined the meeting for Agenda Items 10A and 10D.

10. NEW BUSINESS:

- A. The Board reviewed the memo titled Significant Defect Repair Project – Phase I Bid Opening Results. On a motion by Director Saadati, seconded by President Bosworth, by a vote of 5-0-0, the Board approved contract for the low bid amount of \$127,800 and a contingency amount of 10%.
- B. The Board reviewed the memo titled Purchase of Uniform T-Shirts. On a motion by Director Kwok, seconded by Director Chen, by a vote of 5-0-0, the Board approved the purchase of uniform t-shirts.
- C. The Board discussed upcoming CASA Winter Conference to be held January 25-27, 2023 in Palm Springs, CA. The entire Board, District Counsel, and two Staff members plan to attend the conference.
- D. The Board reviewed the memo titled Cupertino and Saratoga Overlay Emergency Spot Repairs - Project Closeout and Final Acceptance. On a motion by Director Saadati, seconded by Director Doyle, by a vote of 5-0-0, the Board accepted the project and authorized payment in the amount of \$54,058.43 to C2R Engineering, Inc, as first and final payment.

11. STAFF REPORTS:

- A. Manager Porter reported on Future Development Projects.
- B. Manager Porter reported on the Monthly Maintenance Summary.

12. CALENDAR ITEMS:

- A. The next regular Board meeting is to be held on Wednesday, December 7, 2022.

13. ADJOURNMENT:

On a motion properly made and seconded, at 8:57 p.m. the meeting was adjourned.

Secretary of the Sanitary Board

President of the Sanitary Board

CUPERTINO SANITARY DISTRICT BOARD MEETING
WEDNESDAY, OCTOBER 19, 2022

The Sanitary Board of the Cupertino Sanitary District convened this date at 7:00 p.m. This meeting was conducted via teleconferencing in accordance with AB 361. The District office at 20863 Stevens Creek Blvd, Suite 100, Cupertino was closed.

1. ROLL CALL:

Acting President Chen called the meeting to order, and the following proceedings were had to wit: Roll call was taken, with the following members in attendance:

Directors present: Angela S. Chen, Taghi S. Saadati, and David A. Doyle. William A. Bosworth and Patrick S. Kwok were both on excused absence.

Staff present: District Manager Benjamin Porter, Deputy District Manager Robert Woodhouse, and Counsel Marc Hynes.

District Consultant: Richard K. Tanaka

Public: None

2. AB 361:

The Board of Directors makes the following findings required by AB 361 in order to continue holding meetings by teleconferencing electronically: (1) the March 4, 2020 Governor's Proclamation of a State of Emergency is still in effect, (2) the County of Santa Clara Health Officer announced on May 10, 2022 that COVID-19 cases are rising again to higher levels than last summer's surge and there is a rise in hospitalizations; she continues to encourage social distancing and advises people wear masks indoors, and (3) due to room capacity limitations, meeting in person would present imminent risks to the health or safety of attendees.

On a motion by Director Saadati, seconded by Director Doyle, by a vote of 3-0-0, the Board approved.

3. PUBLIC COMMENTS:

There were none.

4. CLOSED SESSION:

Acting President Chen adjourned the regular meeting session and opened the closed session at 7:02 p.m. Manager Porter, and Deputy Manager Woodhouse were excused from the closed session.

- A. Conference with legal counsel – Existing Litigation in accordance with government code section Paragraph (1) of Subdivision (d) of Section 54956.9, existing litigation. Name of Case: County Sanitation District 2-3, West Valley Sanitation District, Cupertino Sanitary District, Burbank Sanitary District, and the City of Milpitas v. The City of San Jose, The City of Santa Clara, and Does 1 through 50 inclusive.

Board action: There was no reportable action.

CUPERTINO SANITARY DISTRICT BOARD MEETING
WEDNESDAY, OCTOBER 19, 2022

Acting President Chen adjourned the closed session at 7:11 p.m. and the regular meeting was called to order. District Manager Porter, and Deputy Manager Woodhouse rejoined the regular meeting.

5. MINUTES & BILLS:

- A. On a motion by Director Saadati, seconded by Director Doyle, by a vote of 3-0-0, the minutes of the regular meeting held Wednesday, October 5, 2022, were approved.
- B. By consensus, the Minutes of Wednesday, September 21, 2022, are to be Noted & Filed.
- C. The Board reviewed September payable warrants and financial statements. Able invoice shows all transactions are on the same date (9/30/2022). Board directed staff to double check the printer cartridge costs and consider transfer of funds from the credit card account to the interest-bearing account. Board On a motion by Acting President Chen, seconded by Director Saadati, by a vote of 3-0-0, the financial statements and payment of bills for September were approved as written.
- D. Board members submitted their October timesheets to Manager Porter.

6. CORRESPONDENCE:

- A. The Board reviewed an email from Local Agency Formation Commission of Santa Clara County (LAFCO) titled LAFCO Certificate of Completion – Cambrian No. 37. It is to be Noted & Filed.

7. MEETINGS:

- A. Manager Porter and Sr. Engineer Kathula both plan to attend the teleconference meeting of The San Jose/Santa Clara Treatment Plant Technical Committee (TAC) to be held on Monday, November 7, 2022.
- B. Director Kwok and/or Director Chen plan to attend the teleconference meeting of The San Jose/Santa Clara Treatment Plant Advisory Committee (TPAC) to be held on Thursday, November 10, 2022.
- C. Deputy Manager Woodhouse plans to attend the CASA Collection Systems Workgroup to be held November 1, 9, and 16, 2022.

8. REPORTS:

- A. Deputy Manager Woodhouse reported on the California Alliance for Sewer System Excellence (CASSE) in-person general meeting hosted by Sacramento Area Sewer District held on October 6, 2022, in Sacramento, CA.

9. UNFINISHED BUSINESS:

- A. District Manager Porter reported on the Covid-19 updates.

10. NEW BUSINESS:

CUPERTINO SANITARY DISTRICT BOARD MEETING
WEDNESDAY, OCTOBER 19, 2022

- A. The Board agreed to table discussion of the Special District Leadership Foundations Transparency Certificate of Excellence at the next regular Board meeting.
- B. The Board reviewed the Draft Annual Report. Board commented they may want to add in the benefits to the homeowner provided by the District.

11. STAFF REPORTS:

- A. Manager Porter reported on Future Development Projects.
- B. Manager Porter reported on the Monthly Maintenance Summary.

12. CALENDAR ITEMS:

- A. The regular Board meeting of November 2, 2022, is cancelled due to three Board members scheduled to be away.
- B. The next regular Board meeting is to be held on Wednesday, November 16, 2022.

13. ADJOURNMENT:

On a motion properly made and seconded, at 8:21 p.m. the meeting was adjourned.

Secretary Pro-Tem of the Sanitary Board

Acting President of the Sanitary Board



County of Santa Clara

Office of the Clerk of the Board of Supervisors

County Government Center, East Wing, 10th Floor
70 West Hedding Street
San Jose, California 95110-1770

(408) 299-5001 FAX 298-8460

October 26, 2022

Subject: Appointment to Cupertino Sanitary District

Dear **Patrick Kwok**:

We are pleased to inform you that on **October 18, 2022**, you were appointed by the Board of Supervisors to serve on the **Cupertino Sanitary District**. We thank you for your interest in serving our County.

Included in this packet:

- Your Certificate of Appointment and Oath of Office: may be executed before a Notary Public or a Deputy Clerk from our office. **Please note you are not considered a voting member of your Commission until your oath is notarized or administered by a Commission Clerk and filed with the Clerk of the Board.** If notarized by a Notary Public, please return your signed oath to:

Office of the Clerk-Board of Supervisors
Attn: Records Unit
70 West Hedding St., East Wing, 10th Floor
San Jose, CA 95110

It would be greatly appreciated if you would return the Oath as soon as possible. However, in the event you are unable to have your oath administered in advance, our staff will be happy to provide this service at the first meeting of the Commission.

- Statement of Economic Interests (Form 700):** new appointees must file an assuming office statement **no later than 30 days from the date of appointment** by the Board of Supervisors. If you have been reappointed, you will receive notification of when to file your annual statement. You have the option of completing your form on-line using the County's electronic Form 700 eFiling system known as eDisclosure. Please note: you must have an **email address on file with the Clerk of the Board's Office** to take advantage of the benefits of this system. This program will assist you in accurately completing your form and electronically submitting your filing. You also have the option to complete the form via paper and return it with original signature to our office by the deadline. Please be advised that the **penalties to you as the filer for failure to file or failure to disclose all reportable interests can include criminal and civil sanctions for intentional or negligent violation of the reporting requirements.** Further, the Clerk of the Board's office has the authority to impose **a penalty against the filer in the amount of \$10 per day after the deadline up to \$100,** and the Fair Political Practices Commission could assess a much higher fine against you for continued failure to file.
- The 2003 Guide on The Brown Act by the California Attorney General's Office. [Please note that several amendments have been made to the Brown Act since 2003 that are not incorporated in this document.] The Ralph M. Brown Act (Gov. Code 54950 et seq.) applies to "legislative bodies" of local

public agencies, as well as any person elected or appointed to serve as a member of a legislative body who has not yet assumed the duties of office. If you have questions regarding the Brown Act, please feel free to call and ask to speak to the Deputy Clerk who is assigned to your commission.

- County of Santa Clara Policy Against Discrimination Harassment and Retaliation
- County of Santa Clara Board of Supervisors Policy on Sexual Harassment
- Federal Equal Employment Opportunity Commission Guidelines on Sexual Harassment
- Guidelines for Filing Discrimination/Harassment Complaints and Complaint Form
- County of Santa Clara Policy on Diversity
- County of Santa Clara Family Expense Reimbursement Policy and Request Form

State Mandated Ethics Training

Pursuant to **California Government Code Section 53235**, as a member of a County Brown Act body, you must receive **two hours** of training in local government ethics within one year of assuming office and once every two years thereafter (often referred to as AB1234 ethics training). The County provides a bi-annual training during even-numbered years; notices are sent out to the County's board and commission members once dates are set, but as an alternative the following option is currently available to meet the requirements for local government ethics training:

- The Fair Political Practices Commission (FPPC) offers **free online training** at <http://localethics.fppc.ca.gov/login.aspx>. This course requires that you log onto the FPPC's website, review the course content materials, and take periodic tests to assure retention of the information. When you complete the online training, you will be able to print a copy of your Proof of Participation Certificate. A copy of the signed certificate must be submitted to the Clerk of the Board. For those who choose this option, please be aware that the certificate will record how much time an individual spends to complete the online training. You must complete **at least 2 hours** of training time in order to be compliant with the training requirement. If an individual completes the online training in less than two hours, the certificate will reflect this, indicating that the individual has not completed the required amount of training. It is each official's responsibility to satisfy the two-hour ethics requirement. Therefore, if you choose to take the FPPC online course, we advise that you take your time and read through the materials as they appear on-screen and thoroughly review the questions in each section to insure you dedicate the required two hours to the online course.

Please note that other types of ethics trainings (e.g., State officials' training or other professional ethics classes) cannot be used to satisfy the AB 1234 ethics training requirement. It is extremely important that you are in compliance with the law.

The County is required to maintain records indicating the date you satisfied your training requirement, the entity that provided your training, and a copy of the Proof of Participation Certificate you received.

When you complete the training you will receive a Proof of Participation certificate, please sign the certificate, keep the original for your records and provide a copy certificate to the **Office of the Clerk of the Board, 70 W. Hedding, East Wing, Tenth Floor, Attn: Ethics Training, San Jose, CA 95110.** The certificates will be retained as public records for at least five years.

State Mandated Sexual Harassment Prevention Training

Pursuant to California Government Code Section 53237, as a local agency official, you must receive two hours of training in sexual harassment prevention and education within six months of assuming office and once every two years thereafter. The law requires training and practical guidance regarding the federal and state statutory provisions concerning the prohibition against, and the prevention and correction of, sexual harassment, and the remedies available to victims of sexual harassment, as well as examples aimed at instructing local agency officials in the prevention of discrimination and retaliation. The County provides this training once every six months; notices are sent out to the County's board and commission members once dates are set. Currently, there is no online training option through our office.

Please note AB 1661 requires local agency officials to complete the same training that has been required for supervisory employees under AB 1825. If you have previously received Sexual Harassment Prevention training that meets the requirements of AB 1661 or AB 1825, you may submit a copy of your proof of participation certificate from that training to the Office of the Clerk of the Board, 70 W. Hedding, East Wing, Tenth Floor, San Jose, CA 95110. The certificate must include your name, date of training, name of training provider, and that the training met the requirements of Sexual Harassment Prevention training under AB 1825 (for supervisors) or AB 1661. It is important that you comply with the law. The County is required to maintain records indicating the date you satisfied your training requirement, the entity that provided your training, and a copy of the Proof of Participation Certificate you received. The certificates will be retained as public records for at least five years.

Parking Permit Information

Commissioners who are not county employees may apply to receive an “A” parking permit to park in county parking lots. Members are not required to apply, however this permits enables the user to park in designated County parking lots. Permits are not required after 5:00 p.m. in lots at 70 W. Hedding and many other County buildings during normal business hours. **NOTE: Parking Permits (permanent or temporary) will not be issued until the Clerk's Office has received your executed Oath of Office.** If you wish to obtain a permit, please contact Les Clark at (408) 299-5001 for an application. Please return the completed, originally signed application form to the Office of the Clerk of the Board - Records Unit for processing.

If you have any questions, please contact the Records Unit at (408) 299-5001.

Sincerely,

Les Clark

Les Clark
Deputy Clerk of the Board

**CERTIFICATE OF APPOINTMENT
BOARD OF SUPERVISORS
COUNTY OF SANTA CLARA, CALIFORNIA**

The Board of Supervisors of Santa Clara County, State of California, does hereby appoint **Patrick Kwok** to the membership of the **Cupertino Sanitary District**.

October 18, 2022

Date Appointed

**Oath of Office
County of Santa Clara,
State of California**

I, **Patrick Kwok**, do solemnly swear (or affirm) that I will support and defend the Constitution of the United States and the Constitution of the State of California against all enemies, foreign and domestic; that I will bear true faith and allegiance to the Constitution of the United States and the Constitution of the State of California; that I take this obligation freely, without any mental reservation or purpose of evasion; and that I will well and faithfully discharge the duties I am about to enter.

A notary public or other officer completing this certificate verifies only the identity of the individual who signed the document to which this certificate is attached, and not the truthfulness, accuracy, or validity of that document

Commissioner Signature

Subscribed and sworn to (or affirmed) before me on this _____ day

of _____, **2022**, by _____,
Print Commissioner Name

proved to me on the basis of satisfactory evidence to be the person(s) who appeared before me.

(SEAL)

Signature: _____
Deputy Clerk or Notary Public
Administering Oath

County of Santa Clara
Office of the County Assessor
County Government Center
70 West Hedding Street
San Jose, CA 95110-1771
Fax (408) 298-9446



Lawrence E. Stone, Assessor

REPORT OF THE COUNTY ASSESSOR

Date Report Prepared: **July 18, 2022**
Title of Proposal: **Lucky Road Annexation No. 1**
Type of Application: **Anx/Detach to City**
Conducting Authority: **City of Monte Sereno**

1. Review of Proposal

- a. Location: vacant land
- b. Assessor's Parcel Numbers: 510-31-077
- c. Respective Net value of assessed parcels as of July 1, 2022: \$493,443 LAND ONLY

2. Conformity to Lines of Assessment or Ownership

- Boundaries of proposal conform.
- Boundaries of proposal fail to conform to lines of assessment per attached map.
- Upon annexation, lines of assessment will no longer be split by TRA lines within this proposal.

3. Special Districts

Special districts within the proposed area include:

TRA 60-007	
060-007 0111 SARATOGA UNION ELEM. SCHOOL	
060-007 0137 LOS GATOS UNION JT(43,44) HIGH SCHOOL	
060-007 0203 WEST VALLEY JT(43,44) COMM. COLLEGE	
060-007 0206 SARATOGA CEMETERY	
060-007 0208 GUADALUPE-COYOTE RESOURCE CONSV.	
060-007 0371 CENTRAL FIRE PROTECTION	
060-007 0252 MID-PENINSULA REGIONAL JT(41,43,44) OPEN SPACE	
060-007 0378 AREA NO. 01 (LIBRARY SERVICES) COUNTY SERVICE	
060-007 0377 AREA NO. 01 (LIBRARY SERVICES), BENEFIT ASSESSMENT COUNTY SERVICE	
060-007 0215 BAY AREA JT(1,7,21,28,38,41,43,48,49) AIR QUALITY MGMT.	
060-007 0322 SANTA CLARA VALLEY COUNTY WATER	
060-007 0376 SANTA CLARA VALLEY-ZONE W-4 COUNTY WATER	
060-007 0335 SANTA CLARA COUNTY IMPORTATION WATER-MISC.	
060-007 0326 SANTA CLARA VALLEY-ZONE C-1 COUNTY WATER	

Prepared By:

Anita Badger, Property & Title Identification Technician

(408) 299-5506
anita.badger@asr.sccgov.org

COPY

WHEN RECORDED, PLEASE MAIL
THIS TO:

LAFCO
777 N. First St., Suite 410
San Jose, CA 95112

Place Clerk Recorder sticker below this line

25407526

Regina Alcomendras
Santa Clara County - Clerk-Recorder
11/23/2022 09:18 AM

CONFORMED COPY

Copy of document recorded.
Has not been compared with original.

CERTIFICATE OF COMPLETION:

LUCKY ROAD #1

DOCUMENT TITLE



**Local Agency
Formation Commission
of Santa Clara County**
777 North First Street
Suite 410
San Jose, CA 95112
SantaClaraLAFCO.org

Commissioners
Rich Constantine
Susan Ellenberg
Sergio Jimenez
Yoriko Kishimoto
Linda J. LeZotte
Mike Wasserman
Susan Vicklund Wilson

Alternate Commissioners
Helen Chapman
Cindy Chavez
Matt Mahan
Russ Melton
Terry Trumbull
Executive Officer
Neelima Palacherla

CERTIFICATE OF COMPLETION

I, Neelima Palacherla, Executive Officer of the Santa Clara County Local Agency Formation Commission, issue this Certificate of Completion pursuant to Government Code Sections 57200 and 57201.

I hereby certify that I have examined **Resolution No. 22-3866** for a change of organization attached hereto and have found this document to be in compliance with Government Code Section 56757 authorizing cities within Santa Clara County to assume authority over certain changes in government organization.

The name of the City is: **Monte Sereno.**

The entire City is located in Santa Clara County.

The change of organization completed is an **ANNEXATION** to the **City of Monte Sereno** and detachment from the following:

NONE

A map and description of the boundaries of the change of organization are appended hereto.

The title of this proceeding is: **Lucky Road #1**

The City has complied with all conditions imposed by the Commission for inclusion of the territory in the City's Urban Service Area.

The change of organization was ordered subject to the following terms and conditions: **NONE.**

The date of adoption of the City Resolution ordering the reorganization is **10/4/2022.**

I declare under the penalty of perjury in the State of California that the foregoing is true and correct.

Dated: 11/18/22

Neelima Palacherla
Neelima Palacherla, Executive Officer
LAFCO of Santa Clara County

Attachments: City Resolution, Legal Description (Exhibit A) and Map (Exhibit B)

RESOLUTION NO. 22-3866

A RESOLUTION OF THE CITY COUNCIL OF THE CITY OF MONTE SERENO TO APPROVE ANNEXATION OF AN UNINHABITED APPROXIMATELY 0.6 ACRE PARCEL ALONG LUCKY ROAD, APN: 510-31-077

WHEREAS, the City of Monte Sereno has received a request for annexation of parcel designated as APN 510-31-077 from Alex Rubashevsky; and

WHEREAS, the property located along Lucky Drive is approximately 0.6 acres and is contiguous to a City boundary and within the City's Urban Service Area, and

WHEREAS, such territory is known by the short form designation of "Lucky Road #1," and a description of the boundaries of this territory is set forth in Exhibit "A," entitled "Geographic Description," attached hereto and incorporated herein by this reference, which description is subject to correction or revision as required; and

WHEREAS, a map showing the location of such territory is attached hereto as Exhibit "B" entitled "Proposed Annexation to City of Monte Sereno of Lucky Road #1," and incorporated herein by this reference;

WHEREAS, the City enacted ordinance NS-190 October 1, 2013 to pre-zone this parcel with R-1-44 zoning district designation; and

WHEREAS the City of Monte Sereno, as Lead Agency for environmental review for the annexation, has determined annexation of the subject property is exempt from the California Environmental Quality Act guidelines, pursuant to Section 15061(b)(3); and

WHEREAS, such territory the County Surveyor of Santa Clara County has found the description and map to be in accordance with Government Code Section 56757, the boundaries to be definite and certain, and the proposal to be in compliance with LAFCO's road annexation policies; and

WHEREAS, as provided in Government Code Section 56757, the City Council of the City of Monte Sereno shall be the conducting authority for a reorganization including an annexation to the City; and

WHEREAS, the proposal does not split lines of assessment or ownership; and

WHEREAS, the proposal does not create islands or areas in which it would be difficult to provide municipal services; and

WHEREAS, the proposal is consistent with the adopted general plan of the City of Monte Sereno; and

WHEREAS, the City Council finds that it has complied with all conditions imposed by LAFCO for inclusion of the territory in the urban service area of the City; and

WHEREAS, the territory is uninhabited and all owners of land included in the proposal have consented to this annexation; and

WHEREAS, Government Code Section 56662(a) provides that if a petition for annexation is signed by all owners of land within the affected territory the Town Council may approve or disapprove the annexation without a public hearing.

WHEREAS, all owners of land included in this proposal have consented to this annexation;

WHEREAS, the City approved Resolution 22-3864 on September 20, 2022 to set a date for consideration of an annexation of this parcel.

NOW THEREFORE, BE IT RESOLVED BY THE CITY COUNCIL OF THE CITY OF MONTE SERENO AS FOLLOWS:

Section 1. Each recital set forth above is hereby adopted as a specific finding of this City Council.

Section 2. The City Council of the City of Monte Sereno hereby approves annexation of the parcel designated as "Lucky Road #1," commonly known as APN 510-31-077.

REGULARLY APPROVED this 4th day of October 2022 by the following roll call vote:

Ayes: LEUTHOLD, MEKECHUK, ELLAHIE
Noes: NONE
Abstain: NONE
Absent: LAWLER, TURNER

DocuSigned by:
Javed I. Ellahie
BY: Javed I. Ellahie, Mayor

ATTEST:
DocuSigned by:
Michelle Estabillo
Michelle Estabillo, City Clerk

The foregoing instrument is a correct copy of the original on file in this office

By *Shirley Ann Johnson*

Dated _____

EXHIBIT 'A'

ANNEXATION TO THE CITY OF MONTE SERENO
LUCKY ROAD #1
GEOGRAPHIC DESCRIPTION

All that certain property situate in the Unincorporated Area of the County of Santa Clara, State of California, being all of that certain parcel of land as described in the Grant Deed from Vladimir Rubashevsky and Galina Rubashevsky, husband and wife and Mark Shats and Natalya Shats, husband and wife to Alex Rubashevsky, an unmarried man, as to an undivided 50% interest; and Eden Shats, an unmarried woman, as to an undivided 50% interest, recorded on July 19, 2013 as Document No. 22308038, Santa Clara County records; being a portion of Lot 3, Section 17, Township 8 South, Range 1 West, Mount Diablo Meridian, more particularly described as follows:

BEGINNING at a point on the southwesterly line of the lands described in EXHIBIT "A" MONTE SERENO, as attached to the Resolution of the Board of Supervisors of the County of Santa Clara, State of California, declaring the result of the Election for the Formation of the City of Monte Sereno as a Municipal Corporation, passed and adopted by the Board of Supervisors of the County of Santa Clara, State of California, May 13, 1957, said point being the northeasterly corner of said parcel of land described in said Document No. 22308038, from which point a corner of the lands described in said EXHIBIT "A" MONTE SERENO, said corner being the most southerly corner of Tract No. 1218, as shown on the map recorded in Book 48 of Maps at Pages 44 and 45, said Santa Clara County records, bears North 44° 33' 00" West, 670.08 feet, said point of beginning being in the southwesterly line of the Rancho Rinconada de Los Gatos;

Thence leaving said "MONTE SERENO" boundary, along the general easterly, southerly, and westerly lines of said parcel of land described in said Document No. 22308038 the following ten (10) courses: 1) South 26° 45' 00" East, 56.10 feet;

Thence (2) South 25° 45' 00" West, 83.16 feet;

Thence (3) South 18° 45' 00" East, 56.10 feet;

Thence (4) South 09° 45' 00" West, 29.04 feet;

Thence (5) South 14° 45' 00" West, 57.42 feet;

Thence (6) South 73° 48' 00" West, 97.35 feet;

Thence (7) North 01° 40' 00" West, 68.64 feet;

Thence (8) North 19° 45' 00" East, 51.00 feet;

Thence (9) North 29° 00' 00" East, 240.00 feet to a point in the southwesterly line of said "MONTE SERENO" boundary and the southwesterly line of the Rancho Rinconada de Los Gatos;

Thence (10) South 44° 30' 00" East, along said southwesterly line, 49.48 feet to the **POINT OF BEGINNING** and containing 0.432 acres of land, more or less.

END OF DESCRIPTION

For assessment purposes only. This description of land is not a legal property description as defined in the Subdivision Map Act and may not be used as the basis for an offer for sale of the land described.

Kristina D. Comerer
Kristina D. Comerer, PLS 6766

Rev. Date: March 19, 2021



DISCLAIMER:
 FOR ASSESSMENT PURPOSES ONLY. THIS DESCRIPTION OF LAND IS NOT A LEGAL PROPERTY DESCRIPTION AS DEFINED IN THE SUBDIVISION MAP ACT AND MAY NOT BE USED AS THE BASIS FOR AN OFFER FOR SALE OF THE LAND DESCRIBED.



EXHIBIT B
 PROPOSED ANNEXATION TO
 CITY OF MONTE SERENO
 LUCKY ROAD #1
 LYING WITHIN
 UNINCORPORATED AREA OF
 SANTA CLARA COUNTY, CALIFORNIA
 SCALE: 1" = 100'
 MARCH 2021

TRACT NO. 121B
 48 M. 44-45

EXISTING
 CITY OF MONTE SERENO
 BOUNDARY

SW LINE RANCHO RINCONADA DE LOS GATOS

N 44°30'00" W 670.08

APN: 510-31-023

APN: 510-31-077
 LANDS OF RUBASHEVSKY, ET AL
 DOC. NO. 22308038

APN: 510-31-076

POINT OF
 BEGINNING

L1 ①

APN: 510-31-031

L2 ②

L3 ③

L4 ④

L5 ⑤

OLD ROAD TO SARATOGA
 N 29°00'00" E

⑨

⑩

⑪

⑫

⑬

⑭

⑮

APN: 510-31-069

240.00
 240.00 WIDE +/-
 NOT 40'00"W
 68.64
 573'48"00"W
 97.35

PROPOSED ANNEXATION
 AREA=0.432 ACRES +/-

LINE TABLE

NO.	BEARING	DISTANCE
L1	S26°45'00"E	56.10
L2	S25°45'00"W	83.16
L3	S18°45'00"E	56.10
L4	S09°45'00"W	29.04
L5	S14°45'00"W	57.42
L6	N19°45'00"E	51.00
L7	S44°30'00"E	49.48

PRTN. LOT 3, S.17, T.8S.,R.1W.,M.D.M.

LEGEND

- BOUNDARY LINE OF PROPOSED ANNEXATION
- - - EXISTING CITY OF MONTE SERENO BOUNDARY



CROSS LAND SURVEYING, INC.
 2210 MT. PLEASANT ROAD
 SAN JOSE, CA 95148
 (408) 274-7994
 PROJECT NO. 13-13



Memo

Item 10A

To: Board of Directors
From: Benjamin T. Porter, District Manager-Engineer
Date: December 7, 2022
RE: Installer's Agreement for Alan Row Development

Background:

On April 25, 2022, the District received plans to demolish the existing Bateh Brothers Liquor and Groceries store and construct four building which will have a total of nine dwelling units.

The Installer, Alan Enterprise, LLC, is to install nine (9) new laterals with property line cleanouts, three (3) 8' PVC mainline segments, which will total 346' LF, and three (3) sanitary sewer manholes.

The Installer has delivered a check payable to the District in the amount of \$182, 498.00, which will cover the Sewer Development Fee of \$89,810.00, the Treatment Plant Capacity Fee of \$22,688.00, the Peak Wastewater Flow Mitigation deposit of \$20,000.00 and the District Administration, Engineering, & Inspection deposit of \$50,000.00.

The Installer has received a copy of the Installer's Agreement and has been instructed to provide a Faithful Performance Bond in the amount of \$296,400.00.

The Installer has demonstrated a willingness to move forward with the Installer's Agreement to move forward with the plans to start construction within the next couple of weeks.

Recommendation:

Staff recommendation to the Board of Directors is to sign the Installer's Agreement upon proof of Faithful Performance Bond

Attachment:

- 1) Installer's Agreement
- 2) Installer's Agreement signed by Installer and dated 11/30/2022
- 3) Faithful Performance Bond

INSTALLER’S

A_G_R_E_E_M_E_N_T

WITHOUT REIMBURSEMENT

THIS AGREEMENT, made this _____ day of _____, 2022, between the CUPERTINO SANITARY DISTRICT of Santa Clara County, California, a public corporation duly organized and existing under Part I Division 6 of the Health and Safety Code of the State of California, hereinafter called “District,” and Alan Enterprise, LLC, owner, hereinafter called “Installer”.

W_I_T_N_E_S_S_E_T_H

WHEREAS, Installer is the owner of a certain real property located at 22690 Stevens Creek Boulevard, Cupertino, CA (APN 342-14-066, APN 342-14-104 and APN 342-14-105), who wishes to construct 9 single-family residential townhouses known as Alan Row Subdivision.

WHEREAS, District is the owner and operator of a certain sanitary sewer system along South Foothill Avenue which will provide service to Alan Row Subdivision;

WHEREAS, District has determined that the one (1) existing sanitary sewer lateral serving all three parcels shall be replaced with 8" PVC SDR26 pipes and will become a new sewer mainline,

WHEREAS, District has determined that the proposed on-site sewer infrastructure will service more than one parcel and therefore must be owned by the District and must be located within a Sanitary Sewer Easement dedicated to the Cupertino Sanitary District,

NOW, THEREFORE, IT IS AGREED, as follows:

- 1) **SEWER CONSTRUCTION**: Installer shall install, or cause to be installed, the said sanitary improvements in strict accordance with the plans, profiles, and specifications approved by District. Installer further hereby agrees to pay any and all costs in connection with the construction of said sanitary sewer facilities, including, but not limited to, materials, work, inspection, supervision, legal, engineering, recording, and all incidental expenses before final acceptance thereof by District.

This project will consist of rehabilitating existing sewer facilities as well as new installations to service the development. Installer shall construct the on-site sewer system, which once accepted, will be owned and maintained by the District. These facilities include:

- A. Sewer Abandonment
 - i. Existing lateral that is connected to existing mainline shall be abandoned and disconnected from the sanitary sewer mainline.
- B. New Construction
 - i. Per Cupertino Building Permit BLD-2022-0634 (Cupertino Sanitary District Permit #22-104):

Pipe Segments						
USMH (CuSD Name)	USMH (BKF Name)	DSMH (CuSD Name)	DSMH (BKF Name)	Length (feet)	Diameter (in)	Material
-	LOT 1	-	Lot 8	165	8	PVC SDR26
-	LOT 8	-	Common LOT	63	8	PVC SDR26
-	Common LOT	L9-45		118	8	PVC SDR26

2) PAYMENT BY INSTALLER:

Installer shall pay to District, prior to execution of this agreement by District, all applicable Sewer Development, Treatment Plant Capacity, District administration, and Peak Wastewater Flow Mitigation fees. The Sewer Development and Treatment Plant Capacity Fees are non-refundable. The Peak Wastewater Flow Mitigation fee is estimated and paid as a deposit with final determination made upon completion of the District's analysis of the Installer's impact on the District's peak wastewater flow. The District administration fees are paid as a deposit and will cover District staff time for plan review, inspection, construction oversight, and construction management as defined in the District's Operation Code. Any un-used funds by the District will be returned to the Installer. If the deposit is not enough to cover the District's review and inspections, additional fees will be required during construction. The fees have been determined as follows:

1)	Sewer Development Fee	\$89,810.00
2)	Treatment Plant Capacity Fee	\$22,688.00
3)	Peak Wastewater Flow Mitigation Fee	\$20,000.00
4)	District Administration, Engineering, & Inspection Fee	\$50,000.00

Total Due: \$182,498.00

3) SECURITY FOR PERFORMANCE OF WORK:

- a. Performance and Payment Bonds. As security for performance of all work necessary for construction of the Sanitary Sewer Facilities and for payment of all labor and material costs pertaining thereto, Installer or its contractor shall furnish to District performance and payment bonds in the amount of \$296,400.00 per attached Exhibit A, on forms provided by District and each in an amount equal to the estimated cost to construct all improvements contemplated by this Agreement, as determined by the District Manager. The performance and payment bonds shall be issued by a surety company admitted to transact business in the State of California, as approved by the District Manager, and shall remain in full force and effect at all times during the performance of the work.
- b. Certificate of Deposit As Security. As an alternative to the delivery of performance and payment bonds pursuant to Paragraph (a) above, Installer may elect to deliver to District a Certificate of Deposit payable to District and issued by a bank acceptable to District, in an amount equal to the estimated cost to construct all improvements contemplated by this Agreement, as determined by the District Engineer. In the event of any default hereunder, District shall be entitled to withdraw any portion or all of the amount deposited irrespective of any interest or penalty that may be charged by the bank for early withdrawal, and District may utilize the funds to complete any unfinished work, or to correct any defective work, or to compensate District for any damage suffered or costs incurred as a result of Installer's default.

- 4) FINAL DESIGN PHASE:
Installer shall submit final plans at the 65% and at the 100% design phases to allow the District to review, provide comments and approve onsite sewer improvements. The design shall conform to the District's standards. Installer shall install, or cause to be installed, the said sanitary improvements in strict accordance with the plans, profiles and specifications approved by the District. Installer's engineer shall submit final plans for District review and approval. Construction may not proceed until the District has approved said sewer improvement plans and other conditions of this Agreement are met.

- 5) INSPECTION:
Installer hereby agrees to provide and assure said District and its employees and any person or persons designated by it the right to inspect said sanitary sewer facilities and the plans, materials and work thereof at any reasonable time or times before, during or after such are installed.

- 6) CCTV INSPECTIONS:
 - A. Installer shall perform closed circuit televised video (CCTV) inspection of all newly constructed sewer mainlines and laterals in accordance with NASSCO PACP & LACP standards.
 - B. Installer shall provide the CCTV report for District's review.

- 7) DEPOSIT:
Installer hereby agrees to deposit, in cash, with District, prior to execution of this agreement by District, a sum to be determined by District in accordance with its current schedule of fees. Said deposit is to be used by District to pay for District's costs for examination of plans, checking of specifications, inspection and other similar engineering charges, together with all costs of administration, supervision, legal, recording, Peak Wastewater Flow Mitigation, and other incidental expenses in connection therewith. Any balance of said sum remaining on deposit after payment of all such charges and costs shall be refunded to Installer. No interest shall be paid by District on the money so refunded. If such deposit is insufficient to pay all such charges and costs, Installer hereby agrees to pay all such charges and costs in excess of the sum so deposited prior to the acceptance of said sanitary sewer improvements by District.

- 8) COMPLIANCE WITH ORDINANCES, RULES AND REGULATIONS:
Installer shall comply with all District ordinances, rules and regulations, as now or hereafter amended. Installer must also comply with all State, County, City, and other agency regulations, rules and ordinances affecting, in any manner, the construction of sanitary sewer facilities, and shall obtain any and all necessary permits and shall pay all fees and charges relating thereto or required therefor.

- 9) TRANSFER OF TITLE:
Upon completion of the construction of said sanitary sewer facilities by Installer and final approval thereof by District, title to said sanitary sewer facilities shall be transferred and conveyed to District. In furtherance thereof, Installer shall execute any and all documents deemed necessary by District for transferring of title thereto simultaneously with the execution of this agreement but to become effective as

hereinafter provided. The documents shall thereupon be deposited with the Secretary of said District, in trust, with instructions to deliver same to District upon its approval of said sanitary sewer facilities as constructed, it being the intention of the parties hereto that such transfer of title shall become effective only upon the final acceptance of said sanitary sewer facilities by the Sanitary Board of the District. Installer waives any and all rights or claim he may have to or for any other consideration from District for said transfer of title, except as is otherwise provided by this agreement.

10) INDEMNIFICATION:

Installer shall defend, indemnify, and hold District, the District Engineer, Mark Thomas & Co. Inc., the County of Santa Clara and the City in which the referred to real property is situated, their officers, agents and employees, free and harmless from any liability or claim of liability for costs and expenses incurred, directly, or indirectly, by Installer in the construction of the sanitary sewer facilities which are the subject of this agreement. Installer further agrees to require its contractor to maintain full insurance coverage of not less than standard limits, and to defend, indemnify and hold District, the District Engineer, Mark Thomas & Co. Inc., the County of Santa Clara and the City in which the referred to real property is situate, their officers, agents and employees, free and harmless from any damage or claim of damage for injury to person or property arising from the activities of Installer and his contractor in the performance of this agreement.

11) SCOPE OF AGREEMENT:

This writing constitutes the entire agreement between the parties, and no modification or waiver of all or any part thereof shall be valid unless in writing and signed by both parties hereto. Waiver by either party of any breach of this agreement shall not be deemed waiver of any subsequent breach of the same or of any other provision of this agreement. If any part of this agreement is held to be indefinite or uncertain or unenforceable, such determination shall not invalidate any other part of this agreement. This agreement shall bind and inure to the benefit of the heirs, administrators, successors, and assigns of the parties hereto.

IN WITNESS WHEREOF, the undersigned have executed this agreement the day and year first above written.

“DISTRICT”
CUPERTINO SANITARY DISTRICT
Santa Clara County, California

By: _____
President of the Sanitary Board of said District

(SEAL)

ATTEST:

Secretary of said District

“INSTALLER”
Alan Enterprise, LLC,
A California Limited Liability Company

By: _____
Ali Mozaffari, President

EXHIBIT A –
SECURITY FOR PERFORMANCE OF WORK

Estimated Cost of Improvements

Description	Quantity	Unit	Unit Price	Amount
Construct New Manhole	3	EA	\$10,000	\$30,000
Install New 8" PVC Sewer Mainline	346	LF	\$400.00	\$138,400
Install New 20 LF 4" SDR-26 PVC lateral with PLCO	9	LS	\$14,000	\$126,000
Connect New Sewer Line to Existing MH	1	LS	\$2,000	\$2,000
Total				\$296,400

INSTALLER'S

A_G_R_E_E_M_E_N_T

WITHOUT REIMBURSEMENT

THIS AGREEMENT, made this 30 day of November, 2022, between the CUPERTINO SANITARY DISTRICT of Santa Clara County, California, a public corporation duly organized and existing under Part I Division 6 of the Health and Safety Code of the State of California, hereinafter called "District," and Alan Enterprise, LLC, owner, hereinafter called "Installer".

W_I_T_N_E_S_S_E_T_H

WHEREAS, Installer is the owner of a certain real property located at 22690 Stevens Creek Boulevard, Cupertino, CA (APN 342-14-066, APN 342-14-104 and APN 342-14-105), who wishes to construct 9 single-family residential townhouses known as Alan Row Subdivision.

WHEREAS, District is the owner and operator of a certain sanitary sewer system along South Foothill Avenue which will provide service to Alan Row Subdivision;

WHEREAS, District has determined that the one (1) existing sanitary sewer lateral serving all three parcels shall be replaced with 8" PVC SDR26 pipes and will become a new sewer mainline,

WHEREAS, District has determined that the proposed on-site sewer infrastructure will service more than one parcel and therefore must be owned by the District and must be located within a Sanitary Sewer Easement dedicated to the Cupertino Sanitary District,

NOW, THEREFORE, IT IS AGREED, as follows:

- 1) **SEWER CONSTRUCTION**: Installer shall install, or cause to be installed, the said sanitary improvements in strict accordance with the plans, profiles, and specifications approved by District. Installer further hereby agrees to pay any and all costs in connection with the construction of said sanitary sewer facilities, including, but not limited to, materials, work, inspection, supervision, legal, engineering, recording, and all incidental expenses before final acceptance thereof by District.

This project will consist of rehabilitating existing sewer facilities as well as new installations to service the development. Installer shall construct the on-site sewer system, which once accepted, will be owned and maintained by the District. These facilities include:

- A. Sewer Abandonment
 - i. Existing lateral that is connected to existing mainline shall be abandoned and disconnected from the sanitary sewer mainline.
- B. New Construction
 - i. Per Cupertino Building Permit BLD-2022-0634 (Cupertino Sanitary District Permit #22-104):

Pipe Segments						
USMH (CuSD Name)	USMH (BKF Name)	DSMH (CuSD Name)	DSMH (BKF Name)	Length (feet)	Diameter (in)	Material
-	LOT 1	-	Lot 8	165	8	PVC SDR26
-	LOT 8	-	Common LOT	63	8	PVC SDR26
-	Common LOT	L9-45		118	8	PVC SDR26

2) PAYMENT BY INSTALLER:

Installer shall pay to District, prior to execution of this agreement by District, all applicable Sewer Development, Treatment Plant Capacity, District administration, and Peak Wastewater Flow Mitigation fees. The Sewer Development and Treatment Plant Capacity Fees are non-refundable. The Peak Wastewater Flow Mitigation fee is estimated and paid as a deposit with final determination made upon completion of the District's analysis of the Installer's impact on the District's peak wastewater flow. The District administration fees are paid as a deposit and will cover District staff time for plan review, inspection, construction oversight, and construction management as defined in the District's Operation Code. Any un-used funds by the District will be returned to the Installer. If the deposit is not enough to cover the District's review and inspections, additional fees will be required during construction. The fees have been determined as follows:

1)	Sewer Development Fee	\$89,810.00
2)	Treatment Plant Capacity Fee	\$22,688.00
3)	Peak Wastewater Flow Mitigation Fee	\$20,000.00
4)	District Administration, Engineering, & Inspection Fee	\$50,000.00

Total Due: \$182,498.00

3) SECURITY FOR PERFORMANCE OF WORK:

- a. Performance and Payment Bonds. As security for performance of all work necessary for construction of the Sanitary Sewer Facilities and for payment of all labor and material costs pertaining thereto, Installer or its contractor shall furnish to District performance and payment bonds in the amount of \$296,400.00 per attached Exhibit A, on forms provided by District and each in an amount equal to the estimated cost to construct all improvements contemplated by this Agreement, as determined by the District Manager. The performance and payment bonds shall be issued by a surety company admitted to transact business in the State of California, as approved by the District Manager, and shall remain in full force and effect at all times during the performance of the work.
- b. Certificate of Deposit As Security. As an alternative to the delivery of performance and payment bonds pursuant to Paragraph (a) above, Installer may elect to deliver to District a Certificate of Deposit payable to District and issued by a bank acceptable to District, in an amount equal to the estimated cost to construct all improvements contemplated by this Agreement, as determined by the District Engineer. In the event of any default hereunder, District shall be entitled to withdraw any portion or all of the amount deposited irrespective of any interest or penalty that may be charged by the bank for early withdrawal, and District may utilize the funds to complete any unfinished work, or to correct any defective work, or to compensate District for any damage suffered or costs incurred as a result of Installer's default.

- 4) **FINAL DESIGN PHASE:**
Installer shall submit final plans at the 65% and at the 100% design phases to allow the District to review, provide comments and approve onsite sewer improvements. The design shall conform to the District's standards. Installer shall install, or cause to be installed, the said sanitary improvements in strict accordance with the plans, profiles and specifications approved by the District. Installer's engineer shall submit final plans for District review and approval. Construction may not proceed until the District has approved said sewer improvement plans and other conditions of this Agreement are met.
- 5) **INSPECTION:**
Installer hereby agrees to provide and assure said District and its employees and any person or persons designated by it the right to inspect said sanitary sewer facilities and the plans, materials and work thereof at any reasonable time or times before, during or after such are installed.
- 6) **CCTV INSPECTIONS:**
 - A. Installer shall perform closed circuit televised video (CCTV) inspection of all newly constructed sewer mainlines and laterals in accordance with NASSCO PACP & LACP standards.
 - B. Installer shall provide the CCTV report for District's review.
- 7) **DEPOSIT:**
Installer hereby agrees to deposit, in cash, with District, prior to execution of this agreement by District, a sum to be determined by District in accordance with its current schedule of fees. Said deposit is to be used by District to pay for District's costs for examination of plans, checking of specifications, inspection and other similar engineering charges, together with all costs of administration, supervision, legal, recording, Peak Wastewater Flow Mitigation, and other incidental expenses in connection therewith. Any balance of said sum remaining on deposit after payment of all such charges and costs shall be refunded to Installer. No interest shall be paid by District on the money so refunded. If such deposit is insufficient to pay all such charges and costs, Installer hereby agrees to pay all such charges and costs in excess of the sum so deposited prior to the acceptance of said sanitary sewer improvements by District.
- 8) **COMPLIANCE WITH ORDINANCES, RULES AND REGULATIONS:**
Installer shall comply with all District ordinances, rules and regulations, as now or hereafter amended. Installer must also comply with all State, County, City, and other agency regulations, rules and ordinances affecting, in any manner, the construction of sanitary sewer facilities, and shall obtain any and all necessary permits and shall pay all fees and charges relating thereto or required therefor.
- 9) **TRANSFER OF TITLE:**
Upon completion of the construction of said sanitary sewer facilities by Installer and final approval thereof by District, title to said sanitary sewer facilities shall be transferred and conveyed to District. In furtherance thereof, Installer shall execute any and all documents deemed necessary by District for transferring of title thereto simultaneously with the execution of this agreement but to become effective as

hereinafter provided. The documents shall thereupon be deposited with the Secretary of said District, in trust, with instructions to deliver same to District upon its approval of said sanitary sewer facilities as constructed, it being the intention of the parties hereto that such transfer of title shall become effective only upon the final acceptance of said sanitary sewer facilities by the Sanitary Board of the District. Installer waives any and all rights or claim he may have to or for any other consideration from District for said transfer of title, except as is otherwise provided by this agreement.

10) **INDEMNIFICATION:**

Installer shall defend, indemnify, and hold District, the District Engineer, Mark Thomas & Co. Inc., the County of Santa Clara and the City in which the referred to real property is situated, their officers, agents and employees, free and harmless from any liability or claim of liability for costs and expenses incurred, directly, or indirectly, by Installer in the construction of the sanitary sewer facilities which are the subject of this agreement. Installer further agrees to require its contractor to maintain full insurance coverage of not less than standard limits, and to defend, indemnify and hold District, the District Engineer, Mark Thomas & Co. Inc., the County of Santa Clara and the City in which the referred to real property is situate, their officers, agents and employees, free and harmless from any damage or claim of damage for injury to person or property arising from the activities of Installer and his contractor in the performance of this agreement.

11) **SCOPE OF AGREEMENT:**

This writing constitutes the entire agreement between the parties, and no modification or waiver of all or any part thereof shall be valid unless in writing and signed by both parties hereto. Waiver by either party of any breach of this agreement shall not be deemed waiver of any subsequent breach of the same or of any other provision of this agreement. If any part of this agreement is held to be indefinite or uncertain or unenforceable, such determination shall not invalidate any other part of this agreement. This agreement shall bind and inure to the benefit of the heirs, administrators, successors, and assigns of the parties hereto.

IN WITNESS WHEREOF, the undersigned have executed this agreement the day and year first above written.

“DISTRICT”
CUPERTINO SANITARY DISTRICT
Santa Clara County, California

By: _____
President of the Sanitary Board of said District

(SEAL)

ATTEST:

Secretary of said District

“INSTALLER”
Alan Enterprise, LLC,
A California Limited Liability Company

By: Ali Mozaffari
Ali Mozaffari, President

EXHIBIT A –
SECURITY FOR PERFORMANCE OF WORK

Estimated Cost of Improvements

Description	Quantity	Unit	Unit Price	Amount
Construct New Manhole	3	EA	\$10,000	\$30,000
Install New 8" PVC Sewer Mainline	346	LF	\$400.00	\$138,400
Install New 20 LF 4" SDR-26 PVC lateral with PLCO	9	LS	\$14,000	\$126,000
Connect New Sewer Line to Existing MH	1	LS	\$2,000	\$2,000
Total				\$296,400



Memo

Item 10B

To: Board of Directors
From: Benjamin Porter, District Manager-Engineer
Date: December 7, 2022
Re: Purchase of one New 20 kW MultiQuip Trailer-Mounted Generator and Rehabilitation of Country Club Pump Station

Background:

Currently, the District has four 20 kW (25 kVA) stand-by generators stored at the District's corporate yard. Nine District pump stations are not equipped with on-site generators for emergency response, in the event of a power failure/outage. In recent months, PG&E had numerous power outages that impacted several District pump stations at the same time. In these instances, it required a lot of effort and manpower to monitor these pump stations and prevent overflows throughout the District. Staff had to haul backup generators stored at District's corporate yard to the stations that had power outages, switch power sources from the main control cabinet (PG&E source) to the backup standby generator and test to make sure all pumps were functioning correctly. This was done by performing several cycles of test runs after letting sewage fill up a portion of the wet well.

At the Country Club Pump Station in Saratoga, power outages occur often. Staff decide to reach out to the management team of the Country Club to see if they would support rehabilitation of the pump station and allow District to construct a concrete pad and install a new permanent generator with a green slate chain link fence enclosure around the generator; and replace the existing asphalt concrete pad around the wet well and the control cabinet due to broken asphalt. This would provide a safe walkway for District staff to perform routine maintenance and prevent rainwater ponds that create muddy areas and make it difficult for maintenance crews to traverse. (See image)



On Friday August 19, 2022, staff met with Diana Moffett (General Manager of Saratoga Country Club). Staff shared the scope of work for the proposed project. Diana requested a drawing with details of the location for the new generator so that she can discuss with her staff to make sure the project is feasible and will not conflict with other agencies.

On Wednesday August 31, 2022, staff submitted a CADD drawing of the proposed concrete pad location for the new generator to Diana for review and comment.

On Tuesday, September 13, 2022, staff received an email confirmation from the Country Club allowing District to move forward with the project.

On Tuesday November 22, 2022, staff conducted a job walk with contractors to see the condition of the project site. At the meeting, staff addressed all concerns and requested contractors to provide a cost proposal to perform the work.

On Tuesday, November 29, 2022, the District opened bids. Two bids were received, one from Able with a cost proposal of \$41,105.00 and Golden Bay Construction cost proposal of \$42,272.00.

The District would benefit from having a new 20-kW MultiQuip trailer mounted standby generator installed permanently at the site as it will provide additional flexibility and reliability, minimization of sewer overflows, and lessen manpower efforts due to power failures/outages.

In addition, District will require St. Francis Electric to perform the electrical work to resplice the generator cable and connect the electrical component from the stand-by generator to the main control cabinet.

Recommendation:

Staff recommends Board approve:

- The purchase of one new 20 kW MultiQuip trailer mounted generator and labor cost to perform electrical work. The total estimate for generator and labor is \$39,248.25.
- Awarding construction to Able Septic Tank at a total cost of \$41,105.00, to be charged to the Major Repair and Maintenance account.
- Approve St-Francis Electric labor estimated at \$6,500, based on time and materials (T&M).

Attachments:

1. C&D Power Quote
2. Able Septic Tank Bid Proposal
3. Golden Bay Construction Bid Proposal



November 30, 2022

QUOTE # QMARKT113022JK-DCA25

Cupertino Sanitary District
Attn : Rick Almondia, Lead Inspector
Phone:(408)253-7863 Office, 408-483-0497 Mobile
Email : ralmondia@markthomas.com

RE: Trailer Mounted 25kVA Generator

Thank you for the opportunity to provide pricing for the generator set and system accessories on the above referenced project. We are pleased to quote as follows:

ITEM 1: Equipment

One(1) MultiQuip DCA25SSIU4F Trailer Mounted Generator

- o ISUSU 4LE2T Diesel Engine
o EPA Tier4 Final, Certified
o Water Cooled, 1800 RPM
o 22Kw, Standby Rating, 20kw Prime Rating
o Multi Voltage, 139/240V 3ph, 277/480V 3ph, 120/240V 1 ph, 60 Hz
o ECU750 Controller
o Block Heater, 500W
o Battery Charger, 3A
o Sub-base Fuel Tank, 41.7 gal, 26 hr run @full load
o Sound Attenuated Enclosure, 65 dba @23 ft
o Main Line Circuit Breaker 60Amp
o Single Axle Trailer, 3500lb GAWR
o Tongue Mounted Swivel Jack, rated 2000lb
o Coupler Options available, can be selected later
* Test and Training 30 minutes at delivery
* Fuel 20 gal for test and demonstration

Total Price, Deliver to Cupertino ----- \$39,248.25(tax included)

Lead time : Late 2023

Alternative Proposal

One(1) Airman SDG25, 25kVA Trailer mounted Generator, compatible with MQ

Price, Deliver to Cupertino, CA ----- \$34,630.00(tax included)

**Lead Time : 2 - 3 weeks

Quotation Notes:

- o Delivery time is an estimate and subject to change
o Any other work except stated above not included

Corporate Headquarters:

150 Nardi Lane
Martinez, California 94553
Phone 925.229.2700
Fax 925.229.2702
Contractor License #757162

Sacramento Branch:

4372 Pinell Street
Sacramento, California 95838
Phone 916.564.2622
Fax 916.564.1083

Clarifications:

1. Upon review, additional charges may be required and thus requoted, if engineering or city inspectors require changes to the initial design we've proposed.
2. Air quality permit fees and compliance are excluded. Local air quality authorities may require a health risk study or environmental quality assessment. The cost for a health risk study is excluded.
3. OSHPD paperwork and certification are excluded. This is the responsibility of the customer.
4. **All permits must be obtained prior to installation of the equipment.**
5. For Diesel Engine Generators. **Do not fuel until pressurized Tank Testing is complete** and signed off by local Hazmat authority.
6. "Engines located on or near school grounds: New Stationary emergency standby diesel-fueled engines (>50 bhp) located on school grounds or 100m or less from a school which exists at the date the application for Permit to Construct or Permit to Operate is deemed complete, whichever is earlier shall emit diesel PM at a rate less than or equal to 0.01 g/bhp-hr" which means that a PM Filter will be necessary. If the generator is within 100 meters of a Kindergarden-12th grade school and there is not a price for a PM Filter on this quote please contact us immediately.

Possible Adder:

-
- Pricing: Valid 30-Days from date on quote. Pricing may be adjusted after submittals and air quality acceptance. Any material pricing increase of 10% or more from date of quote will result in charge order for additional material cost.
- Restocking: A restocking fee of 15% will apply for cancellation after receipt of purchase order and up to 60 days prior to scheduled order shipment date. Cancellation 60 days or less before scheduled shipment date will result in full PO charges.
- Storage: CD & Power will not be held responsible for damage, burglary or vandalism that may occur while equipment is stored at our facility. Storage for more than one month will result in a \$100.00/week storage fee. A secondary shipping and/or crane charge to jobsite may also apply.
- Supply chain: Delays due to supply chain issues can be expected and any associated cost with delays in supply chain are not included in the quoted price. Material cost increases incurred during contract period of more than 3% will be added to the cost of the project.

Please do not hesitate to give us a call with questions or concerns.

Sincerely,

James Kim
925-229-2700 X128

CONDITIONS OF SALE

The Terms and Conditions of Sale below constitute an Agreement between CD & Power and Customer. The provisions of this agreement supersede all prior agreements, negotiations, representations and warranties whether written, oral or otherwise, and no waiver, alteration, or modification of this agreement shall be binding unless agreed to in writing and signed by both CD & Power and customer.

QUOTATIONS are valid for thirty (30) days from the date of quotation unless agreed to in writing by CD & Power. Any material pricing increase of 10% or more from date of quote will result in charge order for additional material cost. A Quotation is not a valid acceptance of an offer to sell unless (1), a Purchase Order signed by an authorized representative of the Customer is received by CD & Power or (2), approved by CD & Power Credit Department. Equipment in stock is subject to prior sale.

A recent California Air Resources Board rule requires that a particulate trap be added to generators for jobs located at or within 100 meters of a school grades K through 12 or day care centers. If your jobsite is within these requirements we will be glad to provide you price adders for the installation of a particulate filter.

SPECIAL ORDERS - A nonrefundable deposit is required for all special order equipment and accessories. The deposit will be applied against the balance of the equipment invoice and cancellation charges, if any.

CHANGES AND MODIFICATIONS - Customer agrees to pay for any changes in scope, design or work plan from that ordered. CD & Power shall have the right to subcontract any or all work covered by the sale. Sale is non-assignable by the Customer without prior written approval of CD & Power.

TERMS - All billings are net fifteen (15) days from the date of invoice upon credit approval. Retention is not acceptable. Customers not adhering to payment terms agree to pay delinquency charges of 1.5% per month or the maximum allowable by law, whichever is greater, on the unpaid balance. If CD & Power commences an action to collect amount due the Customer agrees to reimburse CD & Power all collection costs, attorney fees and court costs.

FINAL ACCEPTANCE - Final acceptance shall occur at time of delivery. Offloading is the Customer's responsibility unless otherwise provided for. Storage and interest charges will result when equipment and accessories ready for shipment to the Customer are held in CD & Power inventory due to Customer's inability to accept delivery.

WARRANTY - All implied warranties including without limitation merchantability and fitness for a particular purpose are excluded from this Agreement. CD & Power disclaims all liability for special, incidental, and consequential damages. The only warranty for equipment sold to the Customer shall be the Manufacturer's warranty. CD & Power obligation is limited to rework or replacement of materials necessary to correct any condition of the equipment resulting from defects in material.

On stationary units, Manufacturer's warranty is not effective until Start Test is performed by CD & Power. Start and Test must be paid in advance.

RETURNED MERCHANDISE - Equipment, accessories and parts cannot be returned without CD & Power written approval. Equipment, accessories and parts must be in salable condition. Customer must pay transportation costs and restocking charge of twenty-five percent (25%) of invoice amount.

SECURITY INTEREST - CD & Power retains and Customer hereby grants CD & Power a Security Interest in equipment sold, including all accessions to and replacements of the equipment, until the Customer has made payment in full in accordance with the provisions herein. Customer shall cooperate fully with CD & Power in executing such documents as CD & Power may deem necessary for the protection of such Security Interest.

TAXES, LICENSES, PERMITS AND INSURANCE - Customer shall pay to CD & Power the amount of any sales, use, excise, duty or similar tax attributable to the sale covered hereby, whether or not included in the purchase or quotation price. CD & Power will assume no responsibility for obtaining permits or licenses other than those specifically provided for. Customer shall reimburse CD & Power for the cost of providing any insurance related rights or waivers associated with CD & Power existing insurance policies. Where taxes do not apply upon sale or resale, Customer shall provide CD & Power with appropriate exemption certificates.

Customer acknowledges that he has not relied on CD & Power skill or judgment in the selection of equipment and that any technical advice or specifications solicited regarding the equipment shall be used at Customer's own risk. Any noncertified drawings provided are descriptive in nature and not warranties of performance.

Except as expressly provided herein, the Agreement shall be governed, construed, and interpreted by the laws of the State of California. The United Nations Convention on Contracts for the International Sales of Goods (CISG) shall not apply. CD & Power elects to opt out of the CISG. Waiver by CD & Power of any breach of the Terms and Conditions of Sale included herein or on any attachment shall not be construed as a waiver of any other breach. Waiver by CD & Power of any breach must be in writing.

CUSTOMER'S REMEDIES - CD & Power shall not be in default and shall not be liable for delays by equipment manufacturers or suppliers or any other circumstances beyond CD & Power **reasonable control**. **Customer's exclusive** and sole remedy on account or in respect of any breach, or to any express or implied warranty, shall be to secure replacement. Correction of any nonconformity shall constitute complete fulfillment of all liabilities of CD & Power. CD & Power aggregate liability in any customer claim shall not, under any circumstances, exceed the payment received by CD & Power for the equipment and services furnished. CD & Power liability shall be limited to those claims arising solely from the acts of the CD & Power. CD & Power shall not be liable whether in contract or in tort or under any other legal theory for loss of revenue, use, or profit or for the cost of any labor expended. Customer agrees to indemnify, save and hold CD & Power harmless for any special, direct, indirect, incidental, accidental or consequential damages to anyone by reason of any breach of contract or of any express or implied warranty.

Payment Intervals upon Acceptance of Proposal:
50% - Mobilization/Equipment Ordered
50% - Upon Pick up or Delivery at Site

The authorized purchaser identified below accepts this proposal and agrees, upon acceptance by CD & Power, to purchase and pay for this equipment, accessories and service in accordance with the CD & Power Conditions of Sale and Standard Terms & Conditions.

Company Name: _____

Contact Name: _____

Purchaser Authorized Signature: _____

Contact Title: _____

Date: _____

Purchase Order: _____



DCA25SSIU4F

Generator

WhisperWatt™

Prime Rating — 20 kW (25 kVA)

Standby Rating — 22 kW (27.5 kVA)

Three-Phase, 60 Hertz, 0.8 PF

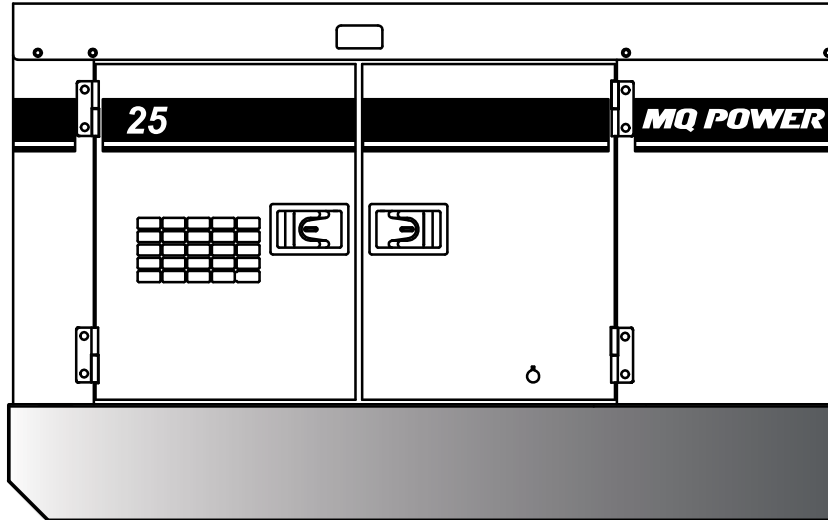

STANDARD FEATURES

- Heavy duty, 4-cycle, direct injection, heated crankcase vent, turbocharged diesel engine provides maximum reliability.
- EPA emissions certified - Tier 4 final emissions compliant.
- Microprocessor engine control system maintains frequency to $\pm 0.25\%$.
- Full load acceptance of standby nameplate rating in a single step.
- Fuel/water separator removes condensation from fuel for extended engine life. Panel mounted alarm light included.
- Sound attenuated, weather resistant, steel housing provides operation at 65 dB(A) at 23 feet. Fully lockable enclosure allows safe unattended operation.
- E-coat and powder coat paint provides durability and weather protection.
- Internal fuel tank with direct reading of fuel gauge.
- Spill containment — Bunded design protects environment by capturing up to 124% of engine fluids.
- Brushless alternator reduces service and maintenance requirements and meets temperature rise standards for Class F insulation systems.
 - Open delta excitation design provides virtually unlimited excitation for maximum motor starting capability.
 - Automatic voltage regulator (AVR) provides precise regulation.
- Fully covered power panel. Three-phase terminals and single phase receptacles allow fast and convenient hookup for most applications including temporary power boxes, tools and lighting equipment. All are NEMA standard.
- ECU754 microprocessor-based digital generator controller.
 - Remote 2-wire start/stop control.
 - Operational temperature range of -40° to 85° C.
- Digital engine gauges including oil pressure, water temperature, battery volts, engine speed and fuel level.
- Analog generator instrumentation including AC ammeter, AC voltmeter, frequency meter, ammeter phase selector switch, voltmeter phase selector switch, and voltage regulator adjustment potentiometer.
- Automatic safety shutdown system monitors the water temperature, engine oil pressure, overspeed and overcrank. Warning lights indicate abnormal conditions.
- Voltage selector switch allows easy to change voltages as your applications require.



DCA25SSIU4F Generator

SPECIFICATIONS

Generator Specifications		
Design	Revolving field, self-ventilated Drip-proof, single bearing	
Armature Connection	Star with Neutral	Zig Zag
Phase	3	Single
Standby Output	22 KW (27.5 KVA)	15.8 KW
Prime Output	20 KW (25 KVA)	14.4 KW
3Ø Voltage (L-L/L-N) Voltage Selector Switch at 3Ø 240/139	208Y/120, 220Y/127, 240Y/139	N/A
3Ø Voltage (L-L/L-N) Voltage Selector Switch at 3Ø 480/277	416Y/240, 440Y/254, 480Y/277	N/A
1Ø Voltage (L-L/L-N) (Voltage Selector Switch at 1Ø 240/120)	N/A	240/120
Power Factor	0.8	1.0
Voltage Regulation (No load to full load)	±0.5%	
Generator RPM	1800	
Frequency	60 Hz	
Winding Pitch	5/6	
No. of Poles	4	
Excitation	Brushless with AVR	
Frequency Regulation: No Load to Full Load	Isochronous under varying loads from no load to 100% rated load	
Frequency Regulation: Steady State	±0.25% of mean value for constant loads from no load to full load.	
Insulation	Class F	
Sound Level dB(A) Full load at 23 feet	65	

Engine Specifications	
Make / Model	Isuzu / 4LE2T
Emissions	EPA Tier 4 Final Certified
Starting System	Electric
Design	4-cycle, water cooled, direct injection, turbocharged, EGR
Displacement	133.0 in ³ (2179 cc)
No. cylinders	4
Bore x Stroke (mm)	85 x 96
Rated Engine Power Output	33.5 hp (25 kW)
BMEP	133 psi (918 kPa)
Piston Speed	1133.9 ft./min. (5.76 m/s)
Compression Ratio	17.6:1
Engine Speed	1800 rpm
Overspeed Limit	2070 rpm
Oil Capacity	2.8 gallons (10.5 liters)
Battery	12V 53Ah x 1

Fuel System		
Recommended Fuel	ASTM-D975-No.1 & No.2-D*	
Maximum Fuel Flow (per hour)	2.3 gallons (8.8 liters)	
Maximum Inlet Restriction (Hg)	6.8 in. (173 mm)	
Fuel Tank Capacity	41.7 gallons (158 liters)	
Fuel Consumption	gph	lph
At full load	1.62	6.12
At 3/4 load	1.26	4.77
At 1/2 load	0.94	3.57
At 1/4 load	0.67	2.52

* - Use ultra-low sulfur diesel fuel.

Cooling System	
Fan Load	0.67 hp (0.5 kW)
Coolant Capacity (with radiator)	2.3 gallons (8.8 liters)
Coolant Flow Rate (per minute)	20.1 gallons (76.0 liters)
Heat Rejection to Coolant (per minute)	1479 Btu (1.56 MJ)
Maximum Coolant Friction Head	14.5 psi (100 kPa)
Maximum Coolant Static Head	3.35 feet (1.04 meters)
Ambient Temperature Rating	104°F (40°C)

Air	
Combustion Air	109 cfm (3.10 m ³ /min)
Maximum Air Cleaner Restriction	25 in. H ₂ O (6.23 kPa)
Alternator Cooling Air	388 cfm (11.0 m ³ /min)
Radiator Cooling Air	1420 cfm (40.2 m ³ /min)
Minimum Air Opening to Room	2.6 ft ² (0.24 m ²)
Minimum Discharge Opening	0.84 ft ² (0.08 m ²)

Exhaust System	
Gas Flow (full load)	148 cfm (4.2 m ³ /min)
Gas Temperature	847°F (453°C)
Maximum Back Pressure	30.1 in. H ₂ O (7.5 kPa)

Amperage	
Rated Voltage	Maximum Amps
1Ø 120 Volt	60 Amps x 2 (Zigzag)
1Ø 240 Volt	60 Amps (Zigzag)
3Ø 208 Volt	60 Amps
3Ø 240 Volt	60 Amps
3Ø 480 Volt	30 Amps
Main Line Circuit Breaker Rating	60 Amps
Over Current Relay Trip Set Point	30 Amps

WARRANTY*

Isuzu Engine**

12 months from date of purchase with unlimited hours or 36 months from date of purchase with 3,000 hours (whichever occurs first).

Generator

24 months from date of purchase or 2,000 hours (whichever occurs first).

Trailer

12 months excluding normal wear items.

*Refer to the express written, one-year limited warranty sheet for additional information.

**Refer to Isuzu Diesel Engine Limited Warranty for details.

NOTICE

Specifications sheet is subject to change and is not intended for use in installation design.



DCA25SSIU4F

Generator

MQ POWER DECIBEL LEVELS

Our soundproof housing allows substantially lower operating noise levels than competitive design. WhisperWatts™ are at home on construction sites, in residential neighborhoods, and at hospitals — just about anywhere.

- 90 — Subway / truck traffic
- 80 — Average city traffic
- 70 — Inside car at 60 mph
— WhisperWatt™ at 23 feet
- 60 — Air conditioner at 20 feet
- 50 — Normal conversation



GENERATOR OUTPUT PANEL

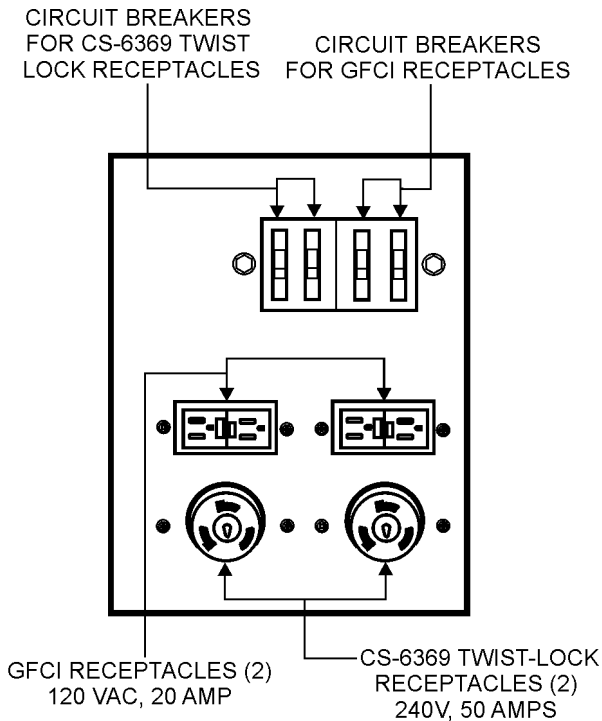

OPTIONAL GENERATOR FEATURES

- **Battery Charger** — provides fully automatic and self-adjusting charging to the generator's battery system.
- **Jacket Water Heater** — for easy starting in cold weather climates.
- **Low Coolant Level Shutdown** — provides protection from critically low coolant levels. Includes control panel warning light.
- **Trailer Mounted Package** — meets National Highway Traffic Safety Administration (NHTSA) regulations. Trailer is equipped with electronic or surge brakes with single or tandem axle configuration.

OPTIONAL CONTROL FEATURES

- **Emergency Stop Switch** — when manually activated shuts down generator in the event of an emergency.
- **Audible Alarm** — alerts operator of abnormal conditions.

OPTIONAL FUEL CELL FEATURES

- **Sub-base Fuel Cells (double wall)** — additional fuel cell for extended runtime operation. Contains a leak sensor, low fuel level switch, and a secondary containment tank. UL142 listed.
- 12 hours of minimum run time.
- 24 hours of minimum run time.

OPTIONAL OUTPUT CONNECTIONS

- **Cam-Lok Connectors** — provides quick disconnect alternative to bolt-on connectors.
- **Pin and Sleeve Connectors** — provides industry standard connectors for all voltage requirements.
- **Output Cable** — available in any custom length and size configuration.



DCA25SSIU4F

Generator

SKID-MOUNT DIMENSIONS

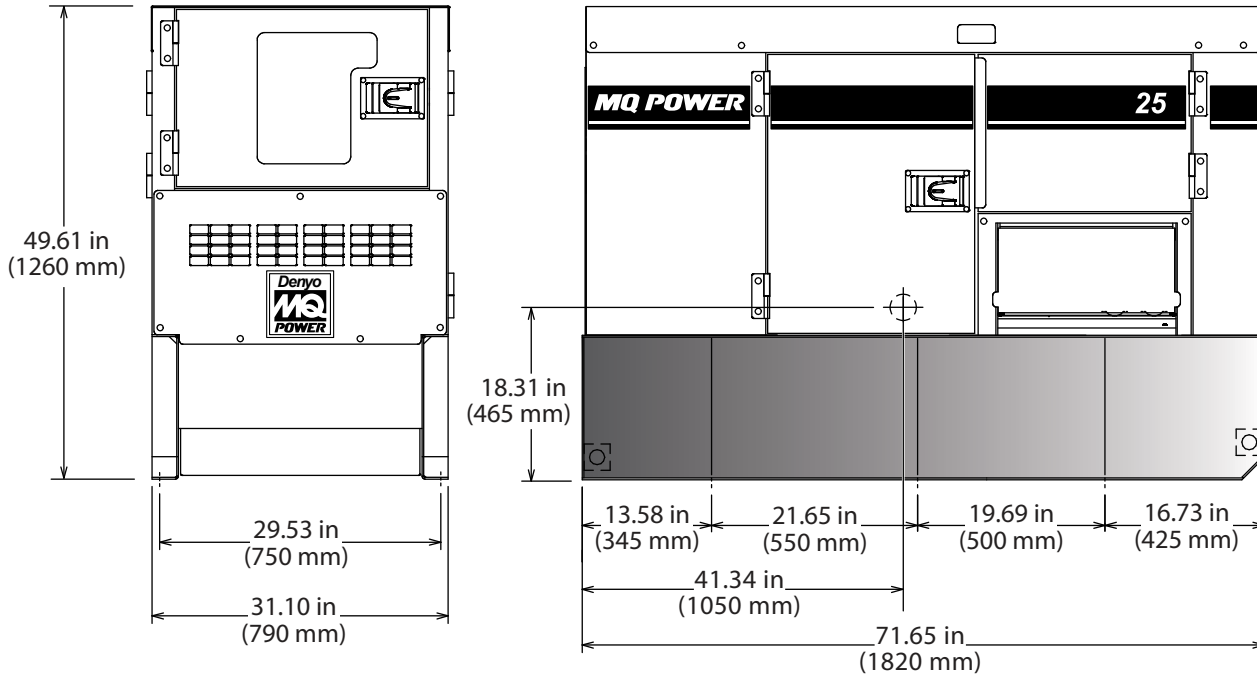

TRAILER-MOUNT DIMENSIONS

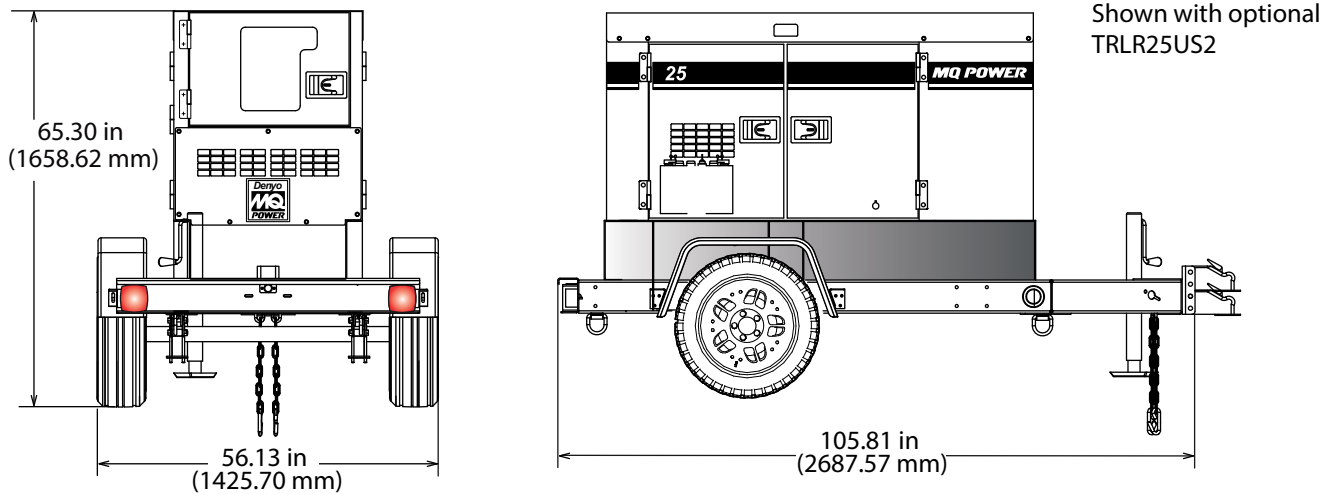

DCA25SSIU4F Weights*

Dry Weight	1,795 lbs. (814 kg)
Wet Weight	2,137 lbs. (969 kg)
Max. Lifting Point Capacity	5,150 lbs. (2,335 kg)

* Weights do not include options.

DCA25SSIU4F and TRLR25US2 Weights*

Dry Weight (with TRLR25US2)	2,239 lbs. (1,016 kg)
Wet Weight (with TRLR25US2)	2,581 lbs. (1,171 kg)

Generator can be placed on MQ Trailer Models TRLR25US and TRLR75XF2.

NOTICE

Features and Specifications are subject to change without notice.



MULTIQUIP
 6141 Katella Avenue Suite 200
 Cypress, CA 90630
 310-537-3700
 E-MAIL: mq@multiquip.com
 WEBSITE: www.multiquip.com



TRLR25US

MQ POWER Single Axle Trailer

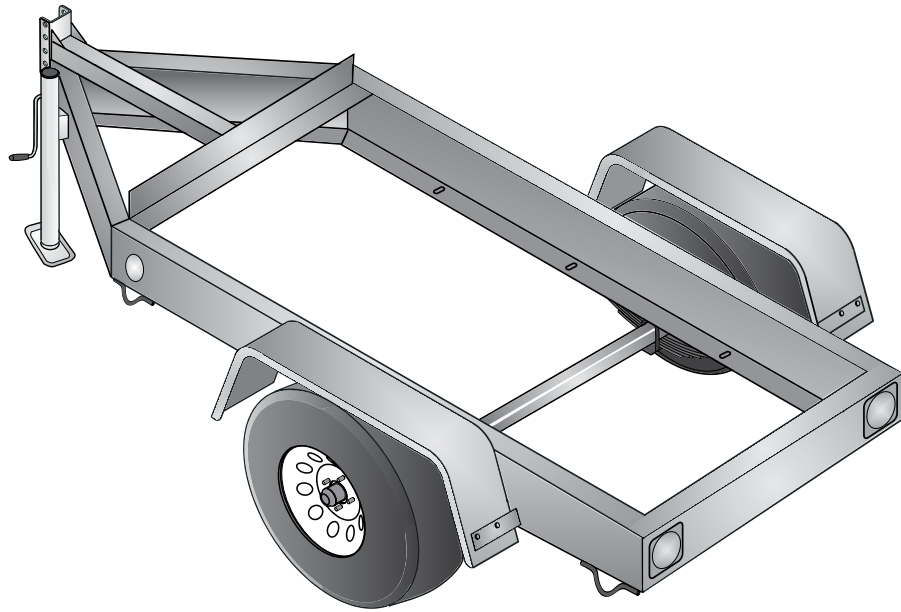

TRLR25US Technical Data	
Gross Vehicle Weight Rating (GVWR) — 2,720 lbs. (1,234 kg)	Tire Size — ST175/80D13 LR-C
Gross Axle Weight Rating (GAWR) — 3,500 lbs. (1,588 kg)	Wheel Bolt Pattern — 5 Lug
Coupler Rating — See coupler options on back page.	Tire Load Rating — 1,360 lbs/617 kg (ea.)

STANDARD TRAILER EQUIPMENT

- Fits MQ Power Generator Model DCA25USI, DCA25SSIU4F
- Single-axle Design with Leaf Spring Suspension
- H.D. Welded Steel Frame Construction
- Formed Channel for Generator Mounting and Support
- 4-hole Channel Allows 3-position, Adjustable Coupler Height; 4-inches O/A
- Tongue Mounted Swivel Jack (rated 2,000 lbs./907 kg lift)
- Replaceable, Bolt-on Steel Fenders
- Powder Coat Paint Process including: Frame, Channel, Actuator and Fenders
- D.O.T. Approved Tail Lamps, Stop Lamps, Turn Signal Lamps, Side Marker Lamps





TRLR25US

MQ POWER Single Axle Trailer

OPTIONAL TRAILER EQUIPMENT

- Pintle Eye 3-inch
- Adjustable 2-inch Ball Coupler
- Adjustable 2 5/16-inch Ball Coupler
- Rear Stabilizer Stands
- Spare Tire with Locking Mount
- Anti-Theft Wheel Lock

Coupler Options

3" Pintle Eye 20,000 lbs. (9,072 kg) #EE36264	
2" Ball Coupler 6,000 lbs. (2,722 kg) #29228	
10,000 lbs. (4,536 kg) #EE43254	
2-5/16" Ball Coupler 14,000 lbs. (6,350 kg) #EE43253	

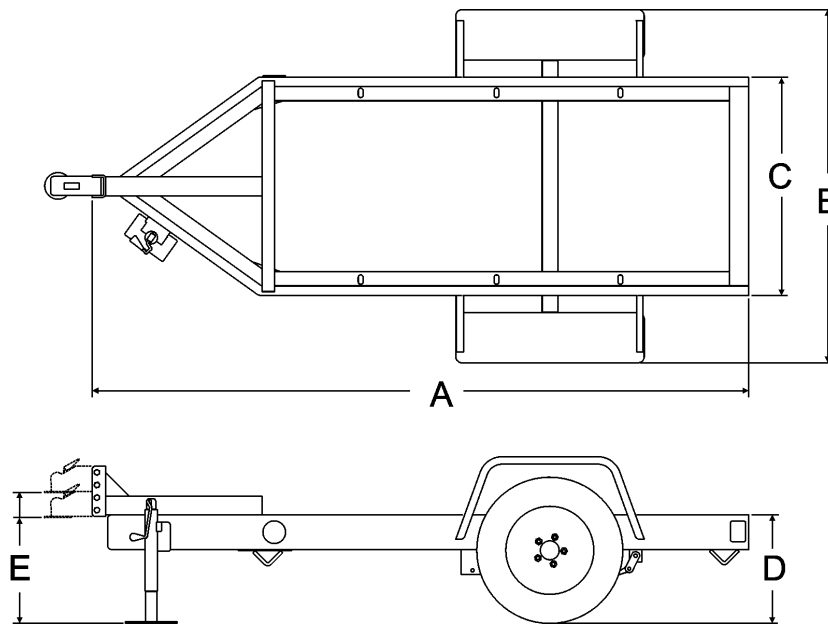

Trailer Dimensions					
A	B	C	D	E	
				MIN	MAX
104.5 in (2,654 mm)	56 in (1,422 mm)	35 in (889 mm)	17 in (432 mm)	17 in (432 mm)	21 in (533 mm)
Trailer Weight					
406 lbs. (184 kg)*					

*Weight is approximate

Your Multiquip dealer is:



MULTIQIP
POST OFFICE BOX 6254
CARSON, CA 90749
310-537-3700 • 800-883-2551
FAX: 310-604-3831
E-MAIL: sales@multiquip.com
WEBSITE: www.multiquip.com

**INVITATION TO BID AND BID FORM**

Project: **Country Club Pump Station Generator**

District: **CUPERTINO SANITARY DISTRICT**
20863 STEVENS CREEK BLVD, STE 100
CUPERTINO, CA 95014

Date: **November 17, 2022**

CONTRACTOR	ADDRESS	PHONE	EMAIL	CONTACT
ABLE Underground	P.O Box 24819 San Jose, CA 95154	(408) 377-9990	glen@ableseptic.com	Glen Gilbert
Nor-Cal Pipeline Services	1875 South Rive Road West Sacramento, CA 95691	(510) 305-4847	bbonney@norcalpipe.com	Bill Bonney
Roto Rooter	356 Mathew Street Santa Clara, CA 95050	(408) 769-9205	rrsc78@rrsc.com	Jason Knieb
Cratus Inc	945 Taraval Street #302 San Francisco, CA 94116	(415) 559-1325	Michael@cratusinc.com	Michael Kirwan
C2R Engineering Inc.	100 Mountain View Ave. Los Altos, CA 94024	(415) 559-2841	trevor@c2rengineering.com	Trevor Connolly
Con-Quest Contractor Inc.	290 Toland Street San Francisco, CA 94124	(415) 206-0524	Alexb@cqccontractors.com	Alex Baranoff
Centinela General Engineering, Inc.	20033 Audrey Lane Salina CA 93907	(831) 240-7529	Jaimecge1@gmail.com	Jaime Vidal
Murgreen Environmental Company	1110 Andreas Lane Tracy, CA 95376	(209) 207-3917	Murgreen.environmental@gmail.com	Felix Oviawe

This request for bids is in compliance with District Ordinance 100, "Informal Bid Process" adopted pursuant to the authority of Article 3 of Chapter 2, Part 3, Division 2 (commencing with Section 22000) of the California Public Contract Code and constitutes an "informal bidding ordinance" as described in Section 22034 of said Code.

Your firm is invited to submit a Bid under seal at the office of the Engineer to the attention of the CUPERTINO SANITARY DISTRICT ("District").

The Contractor's registration with the Cupertino Sanitary District must be current. The District has the right to disqualify contractors who fail to renew their registration. If your firm is not currently registered, please contact the District for information.

The District will receive Bids until 3:00 PM local standard time on November 29, 2022

This project is a public works contract within the meaning of Part 7 (commencing with Section 1720) of Division 2 of the Labor Code of the State of California and the requirements of prevailing rate of wages apply to this contract. Pursuant to Section 1773 of the Labor Code, the general prevailing rate of wages in the county in which the work is to be done has been determined by the Director of the Department of Industrial Relations.

Submit your Bid on the Bid Form provided.



BID FORM

To: CUPERTINO SANITARY DISTRICT
MARK THOMAS & COMPANY, INC.
20863 STEVENS CREEK BLVD., SUITE 100
CUPERTINO, CA 95014

Project Name: Country Club Pump Station Generator

Project Description: The WORK includes providing all labor, materials, tools, and equipment necessary for completing list below.

- Furnishing and installing approximately ninety lineal feet (80') of 1 1/2-inch conduits Schedule 80, installation of risers and 90 degrees bend core into existing electrical panel and through concrete slab.
- Install forty-eight lineal feet (48'-0") of six feet (6'-0") tall chain link fence with green colored slats including ten feet (10'-0") wide chain link gate.
- Clearing and grubbing the site, and install SWPPP along the embankment. Install ten by fourteen (10' x14') concrete pad, removing and replacing asphalt concrete with four (4) inch hot mix asphalt concrete around the existing wetwell and electrical panel concrete pedestal.
- Install new work light pole

Contractor must provide Traffic Control Plan to the governing City/County where the repair is located and required TC plan. All Traffic Control Work for construction shall conform to the California Manual on Uniform Traffic Control Devices (CA MUTCD Latest Edition), Caltrans Specifications and Standard Plans, Dated 2018. The Traffic Control Plan must be approved and meet the requirements to pull an Encroachment Permit for the awarded repair. Contractor must always provide safe and continuous passage for all golf players and maintenance vehicle traffic for the Golf Course. This WORK includes replacing any damaged landscaping, or onsite properties to its original condition at the Contractor's expense. Contractor shall complete said work in accordance with these bid form, District Standard, District Specifications and as directed by the Engineer. Contractor shall coordinate with the District to perform all the work above. All the WORK shall be completed to the satisfaction of District. District will make the final inspection. If District determines that the WORK has completed, in accordance with the Bid Documents, District will recommend that the WORK be accepted. Contractor will be relieved of the responsibility imposed on the date of Acceptance.

Additional details can be found in the plan sheet includes with the bid package

Job walk is held on: Tuesday, November 22nd at 10am

Bid Date & Time: Tuesday, November 29th at 2pm

Submitted by:

Able Septic Tank
Full Contractor Name

1020 Ruff Dr SS CA 95110
Full Address City State ZIP

408.377.9990 mark@ableseptic.com
Phone No. E-mail Contact

1. OFFER

Having examined the Place of the Work and all matters referred to in the Instructions to Bidders, Bid Forms, Plans prepared by the Engineer for the above-mentioned project, we, the undersigned, hereby agree to perform the Work for the Unit Prices listed in this bid form, complete in place and as directed by the Engineer.

2. ACCEPTANCE

This offer shall be open to acceptance and is irrevocable for fifteen (15) days from the bid opening date. If this bid is accepted by the District within the time period stated above, District Manager will issue Notice to Proceed.

3. CONTRACT TIME

Complete the Work in **thirteen (13) working days** from date Notice to Proceed.

4. UNIT PRICES

The following are Unit Prices for Bid Items for the Work as listed.

Item No.	Item	Unit of Measure	Estimated Quantity	Unit Price (In Figures)	Item Total (In Figures)
1	SITE PREPARATION (Includes but not limited to mobilization, clearing & grubbing, excavation, SWPPP Storm Water Pollution Prevention Plan, and grading)	LS	1		2,903. ⁰⁰
2	MINOR CONCRETE (includes formwork, reinforcement, Class 2 AB, removal of formwork, and backfilling around the pad). Concrete shall be cured for 14 days prior to placing generator	CY	3		4,390. ⁰⁰
3	INSTALL 1 1/2" CONDUITS (includes but not limited to trenching, backfill and AC, coring, conduits/riser and connecting conduits)	LF	80		7,290. ⁰⁰
4	6'-0" CHAIN LINK FENCE with green colored slats (includes but not limited to installation of slats, posts, swing gates and concrete backfill for post)	LF	48		9,597. ⁰⁰
5	INSTALLING GENERATOR (Work includes getting the Generator from District's Corp Yard (Florence Pump Station), power cable box mounted behind trailer, lifting in place, and securing the Generator, Generator ground rod.	LS	1		1,170. ⁰⁰
6	ASPHALT CONCRETE REPAIR (includes removal of ex. AC pavement and replacement with new Hot Mix AC as shown on the plans)	TONS	8		10,080. ⁰⁰
7	INSTALL NEW WORK LIGHT POLE (includes but not limited to install of post, conduit, junction box, light bulb halogen with motion sensor capability and wires).	EA	1		5,675. ⁰⁰

TOTAL BID: 41,105.⁰⁰

5. **BID FORM SIGNATURES**

The Corporate Seal of:

Abu Sepkie Tank
(Bidder - Print the Full Name of your Firm)

was hereunto affixed in the presence of:

GM
(Authorized signing Officer Title)

(Seal)

GM
(Authorized signing Officer Title)

(Seal)



BID FORM

To: **CUPERTINO SANITARY DISTRICT**
MARK THOMAS & COMPANY, INC.
20863 STEVENS CREEK BLVD., SUITE 100
CUPERTINO, CA 95014

Project Name: Country Club Pump Station Generator

Project Description: The WORK includes providing all labor, materials, tools, and equipment necessary for completing list below.

- Furnishing and installing approximately ninety lineal feet (80') of 1 1/2-inch conduits Schedule 80, installation of risers and 90 degrees bend core into existing electrical panel and through concrete slab.
- Install forty-eight lineal feet (48'-0") of six feet (6'-0") tall chain link fence with green colored slats including ten feet (10'-0") wide chain link gate.
- Clearing and grubbing the site, and install SWPPP along the embankment. Install ten by fourteen (10' x14') concrete pad, removing and replacing asphalt concrete with four (4) inch hot mix asphalt concrete around the existing wetwell and electrical panel concrete pedestal.
- Install new work light pole

Contractor must provide Traffic Control Plan to the governing City/County where the repair is located and required TC plan. All Traffic Control Work for construction shall conform to the California Manual on Uniform Traffic Control Devices (CA MUTCD Latest Edition), Caltrans Specifications and Standard Plans, Dated 2018. The Traffic Control Plan must be approved and meet the requirements to pull an Encroachment Permit for the awarded repair. Contractor must always provide safe and continuous passage for all golf players and maintenance vehicle traffic for the Golf Course. This WORK includes replacing any damaged landscaping, or onsite properties to its original condition at the Contractor's expense. Contractor shall complete said work in accordance with these bid form, District Standard, District Specifications and as directed by the Engineer. Contractor shall coordinate with the District to perform all the work above. All the WORK shall be completed to the satisfaction of District. District will make the final inspection. If District determines that the WORK has completed, in accordance with the Bid Documents, District will recommend that the WORK be accepted. Contractor will be relieved of the responsibility imposed on the date of Acceptance.

Additional details can be found in the plan sheet includes with the bid package

Job walk is held on: Tuesday, November 22nd at 10am

Bid Date & Time: Tuesday, November 29th at 2pm

Submitted by: Golden Bay Construction, Inc.
Full Contractor Name

3826 Depot Rd, Hayward, CA 94545
Full Address City State ZIP

510-783-2960 johnny@gbayinc.com
Phone No. E-mail Contact

1. OFFER

Having examined the Place of the Work and all matters referred to in the Instructions to Bidders, Bid Forms, Plans prepared by the Engineer for the above-mentioned project, we, the undersigned, hereby agree to perform the Work for the Unit Prices listed in this bid form, complete in place and as directed by the Engineer.

2. ACCEPTANCE

This offer shall be open to acceptance and is irrevocable for fifteen (15) days from the bid opening date. If this bid is accepted by the District within the time period stated above, District Manager will issue Notice to Proceed.

3. CONTRACT TIME

Complete the Work in **thirteen (13) working days** from date Notice to Proceed.

4. UNIT PRICES

The following are Unit Prices for Bid Items for the Work as listed.

Item No.	Item	Unit of Measure	Estimated Quantity	Unit Price (In Figures)	Item Total (In Figures)
1	SITE PREPARATION (Includes but not limited to mobilization, clearing & grubbing, excavation, SWPPP Storm Water Pollution Prevention Plan, and grading)	LS	1	15,872.00	15,872.00
2	MINOR CONCRETE (includes formwork, reinforcement, Class 2 AB, removal of formwork, and backfilling around the pad). Concrete shall be cured for 14 days prior to placing generator	CY	3	1,800.00	5,400.00
3	INSTALL 1 ½" CONDUITS (includes but not limited to trenching, backfill and AC, coring, conduits/riser and connecting conduits)	LF	80	55.00	4,400.00
4	6'-0" CHAIN LINK FENCE with green colored slats (includes but not limited to installation of slats, posts, swing gates and concrete backfill for post)	LF	48	119.00	5,712.00
5	INSTALLING GENERATOR (Work includes getting the Generator from District's Corp Yard (Florence Pump Station), power cable box mounted behind trailer, lifting in place, and securing the Generator, Generator ground rod.	LS	1	1,160.00	1,160.00
6	ASPHALT CONCRETE REPAIR (includes removal of ex. AC pavement and replacement with new Hot Mix AC as shown on the plans)	TONS	8	857.00	6,856.00
7	INSTALL NEW WORK LIGHT POLE (includes but not limited to install of post, conduit, junction box, light bulb halogen with motion sensor capability and wires).	EA	1	2,872.00	2,872.00

TOTAL BID: 42,272.00

5. BID FORM SIGNATURES

The Corporate Seal of:

Golden Bay Construction, Inc.
(Bidder - Print the Full Name of your Firm)

was hereunto affixed in the presence of:

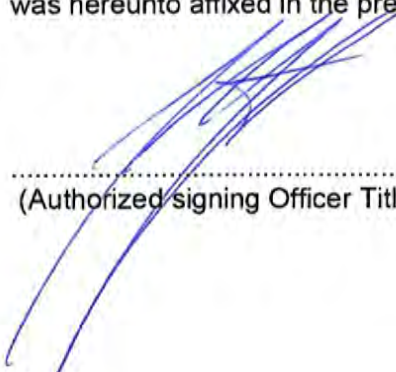
.....
(Authorized signing Officer Title)

(Seal)

President
(Authorized signing Officer Title)

(Seal)

**CUPERTINO SANITARY DISTRICT
MEETING/EVENT SCHEDULE**

DECEMBER 2022

12/05: TAC
 12/05: SCCSDA
 12/07: CASSE
 12/07: 1st Regular Meeting
 12/08: TPAC
 12/21: 2nd Regular Meeting

DECEMBER 2022						
Sunday	Monday	Tuesday	Wednesday	Thursday	Friday	Saturday
				1	2	3
4	5 TAC SCCSDA	6	7 CASSE 1 st Regular Meeting	8 TPAC	9	10
11	12	13	14	15	16	17
18	19	20	21 2 nd Regular Meeting	22	23	24
25	26 HOLIDAY	27	28	29	30	31

JANUARY 2023

01/04: 1st Regular Meeting
 01/09: TAC
 01/12: TPAC
 01/18: 2nd Regular Meeting
 01/25-27: CASA Winter Conference

JANUARY 2023						
Sunday	Monday	Tuesday	Wednesday	Thursday	Friday	Saturday
1	2 HOLIDAY	3	4 1 st Regular Meeting	5	6	7
8	9 TAC	10	11	12 TPAC	13	14
15	16	17	18 2 nd Regular Meeting	19	20	21
22	23	24	25	26	27	28 CASA CONFERENCE
29	30	31				

FEBRUARY 2023

02/01: 1st Regular Meeting
 02/06: TAC
 02/09: TPAC
 02/15: 2nd Regular Meeting

FEBRUARY 2023						
Sunday	Monday	Tuesday	Wednesday	Thursday	Friday	Saturday
			1 1 st Regular Meeting	2	3	4
5	6 TAC	7	8	9 TPAC	10	11
12	13	14	15 2 nd Regular Meeting	16	17	18
19	20	21	22	23	24	25
26	27	28				