

Dura-soft Bumpers

USES/APPLICATIONS

- Standard sizes shipped within
- Provides maximum protection with a unique "loop" design of bumper pads--the greatest impact absorption available on the market.
- Design has been thoroughly tested to prove that it provides maximum protection.
- Ideal for use in docking areas where excessive friction from up-and-down trailer movement occurs.
- Can be used in any material handling system/area where heavy-duty protection is required.

MATERIAL/THICKNESS

- Rubber pads 4" thick with loop pad and 3/8" steel face for overall thickness at 5-1/2".

INSTALLATION

- Structural mounting angles permit welded installation or provide bolting through steel.
- No assembly required.

SPECIFICATIONS

- Resilient rubber material of bumpers shall be cut to uniform size pads 4" thick with overall projection of 5 1/2". Longer looped pads inserted between standard spacer pads to allow approximately 1/2" flex of looped pads upon impact. Pads punched to receive 3/4" supporting rods
- Plate to be welded to slotted steel support plates which extend back to the 3/4" supporting rods. Brackets to be punched with elongated slots to allow steel-face to "float" on impact.
- Black powder coat finish only



FEATURES

- Unparalleled ability to deflect and absorb shock with loop design laminated beneath a floating steel face
- Available in a variety of dimensions and can be mounted at various heights, from flush mount to 12" above the dock.

BENEFITS

- Maximum dock a truck protection available
- Eliminates wear from up and down trailer movement
- Impervious to weather damage
- Maintenance free
- 5 year warranty
- Cost effective

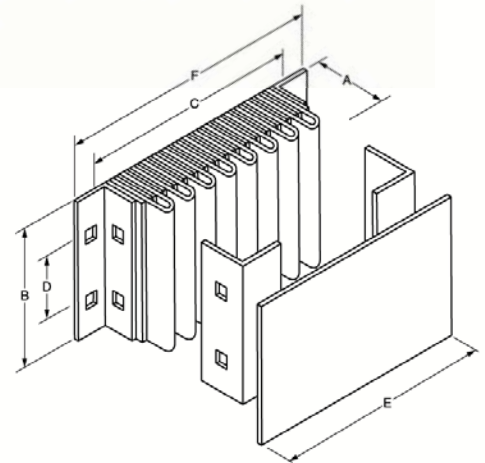

Model	Standard Sizes (A x B x C)	D Vertical Bolt Hole Centers	E Rubber Length	F Overall Length	Approximate Weight
B5510-14-DS	5.5" X 10" x 14"	6"	10"	16"	48
B5510-18-DS	5.5" X 10" x 18"	6"	14"	20"	60
B5510-24-DS	5.5" X 10" x 24"	6"	20"	26"	86
B5510-36-DS	5.5" X 10" x 36"	6"	32"	38"	127
B5512-14-DS	5.5" X 12" x 14"	4"	10"	16"	52
B5512-18-DS	5.5" X 12" x 18"	4"	14"	20"	67
B5512-24-DS	5.5" X 12" x 24"	4"	20"	26"	93
B5512-36-DS	5.5" X 12" x 36"	4"	32"	38"	143
B5520-11-DS	5.5" X 20" x 11"	6"	7"	13"	84
B5524-11-DS	5.5" X 24" x 11"	4"	7"	13"	101
B5536-11-DS	5.5" X 36" x 11"	4"	7"	13"	149

Note: 1/4" Flat plates may be substituted for one or both angles.