

INSTALLATION INSTRUCTIONS

MODEL: 40030 DELUXE HOIST STORAGE SYSTEM W/ ACCESSORY STRAPS

THANK YOU FOR YOUR PURCHASE. We take a **SATISFACTION GUARANTEED** approach to our products and our business, if you are not satisfied in any way, or if we can provide you with assistance or information, PLEASE call us TOLL FREE at 800-346-7332 or e-mail us at contactus@mygearup.com.

The GEARUP™ Deluxe Hoist System is designed to hold one non-motorized bicycle, ladder, small canoe or kayak, car-top carrier, or other items of similar dimensions and weight.



Figure A

Bill of Material:

A.	40030C	Hoist Lifting Pulley w/LOC Mechanism	1
B.	40030D	Hoist Pulley	1
C.	40030E	Hoist Lifting Hook Set	2
D.	40030F	Hoist Flush Ceiling Mounting Bracket	2
E.	40030G	Hoist Rope – 49 foot length	1
F.	40030H	Hoist Rope Tie Off Cleat	1
G.	40030J	Hoist Phillips Hex Head Lag Bolt 2 ½"	4
H.	40030K	Hoist Phillips Head 1 1/2" Screw	2
I.	40030L	Hoist Mounting Bolt	4
J.	40030M	Hoist Mounting Bolt Matching Nut	4
K.	40035	Hoist Accessory Strap	2

SAFETY NOTICE

READ BEFORE INSTALLING AND USE

- BEFORE DRILLING & INSTALLING** mounting hardware – **BE SURE NO** electrical, gas, water, or other obstructions will be interfered or damaged. **NOTE:** Drilling into electrical or gas lines can result in serious injury, death, and/or fire. If unsure of the exact location of these obstructions, seek Professional help.
- DO NOT INSTALL** over personnel, work areas, and/or walkways.
- BEFORE INSTALLING** – **BE SURE** structure where Hoist System is to be attached is **ADEQUATE** enough to support the Hoist and the load(s) to be lifted. If unsure, seek Professional help.
- BEFORE LIFTING** – **BE SURE** the item's total weight falls within the stated weight restriction of 120 pounds.
- BEFORE LIFTING** – **BE SURE** weight of the load is evenly distributed between both lifting hooks.
- BEFORE LIFTING** – **BE SURE** no person and/or animals are under or near the load to be lifted.
- BEFORE LIFTING** – **BE SURE** the lifting hooks are fully attached to the load and/or accessory straps and the hooks cannot become disengaged.
- BEFORE LIFTING** – perform visual check of the Hoist System ensuring it is firmly attached to the ceiling.
- BEFORE LIFTING** – perform visual check of the rope. **DO NOT USE** if the rope shows signs of wear. **REPLACE ROPE** at first sign of wear or at least once annually.
- MAXIMUM WEIGHT** capacity is 120 pounds (60 pounds per each lifting hook set).
- The Hoist System is designed for indoor use **ONLY**.

INSTALLATION INSTRUCTIONS

STEP ONE – Determine Location

1. Determine location where the Hoist System is to be installed. Remember, check for electrical, gas, water, and/or other items that could be compromised or damaged during the installation.
2. The ceiling area where the Hoist System is to be attached, **MUST BE** a solid structure and capable of holding the Hoist System and the item being lifted.
3. The 2 – Pulleys should be installed so that the arms hang directly below the mounting brackets at a 90 angle when holding the primary item to be stored. For example, if one were going to use the deluxe hoist system primarily for hoisting a bicycle, the center to center measurement between the two mounting brackets should be approximately the same distance apart as the two “grab points” on the bicycle (which should be the seat and the handle bars).
4. The location selected **MUST PROVIDE** adequate clearance to walls and other obstructions.

STEP TWO – Determine Type of Installation

The Hoist System can be installed directly to an exposed ceiling joist or to a flat (Finished Ceiling). Please note the 2 examples as shown below. The final determination will be based on the type of ceiling where the Hoist is to be installed.

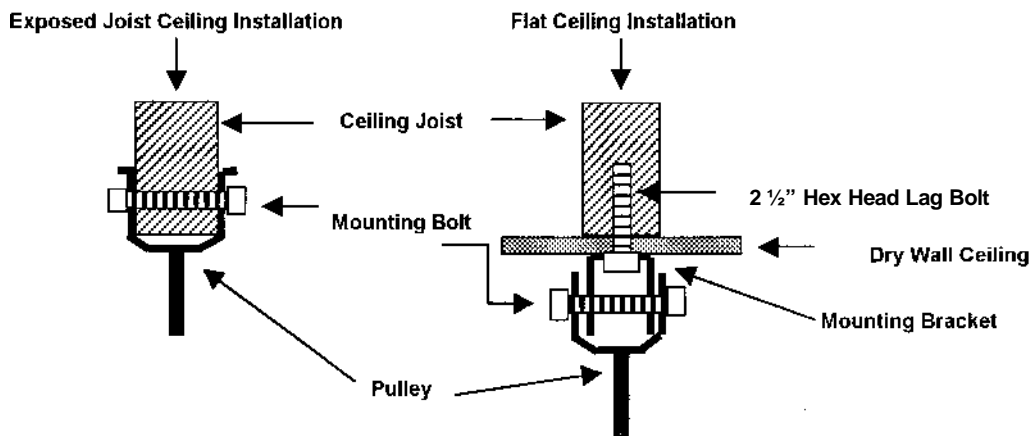

STEP THREE – Exposed Joist Installation (For Flat Ceilings go to STEP FOUR)

1. Once the location has been determined, position the lifting pulley (40030C) over the joist as shown in the drawing above. Mark the location of the two 3/8" holes for the mounting bolts.
2. Drill the 2 holes just marked using a 3/8" drill bit.
3. Re-position the lifting pulley (40030C) and insert 2 bolts as shown above. Attach 2 nuts and tighten.
4. Position lifting pulley (40030D), not to exceed 5 feet from pulley 40030C, and repeat steps 1-2-3 above.
5. Attach Rope Tie-Off Cleat (40030H) to nearby wall using 2 screws (40030K).
6. Before attempting to use the newly installed Hoist System, please closely review all procedures and warnings contained herein.

STEP FOUR – Flat (Finished) Ceiling Installation

1. Once the location has been determined, locate & mark the centerline of the joist where the first mounting bracket will be attached.
2. Position first mounting bracket (40030F), open side down, along centerline marked above, and mark the 2 mounting holes. **NOTE:** As shown in the picture above, the mounting screw must go into the center of the joist.
3. Drill two 1/8" pilot holes through the flat ceiling and into the center of the joist.
4. Re-position the mounting bracket and attach using two 2 1/2" Bolt (40030J). Bracket must be tightly attached to the ceiling.
5. Position second mounting bracket (40030F) and repeat steps 2-3-4 above. **NOTE:** Both brackets must be in a straight line to one another.
6. Determine lifting side (side of rope), and attached lifting bracket (40030C) to the first mounting bracket (40030F) using two bolts (40030L). Screw on nuts (40030J) and tighten.
7. Attach second lifting pulley (40030D). Refer to Figure A for proper positioning of both brackets.
8. Attach rope Tie-Off Cleat to desired wall position using two 1 1/2" screws (40030K).
7. Before attempting to use the newly installed Hoist System, please closely review all procedures and warnings contained herein.

INSTRUCTIONS FOR USING THE HOIST SYSTEM

Lifting and Storage

1. **DO NOT** exceed weight limitation of 120 total pounds.
2. **MAKE SURE** no people or pets are under or near the load to be lifted.
3. **UNTIE** rope from the Tie-Off Cleat, and lower the lifting hooks by releasing the rope locking mechanism. To release, pull the rope straight down. Without any weight, you may have to gently pull the hooks downward, keeping the 2 hook sets even to one another.
4. **ATTACH** the lifting hooks to the item to be lifted. **BE SURE** the load is evenly balanced between the 2 hooks, and that the weight is evenly distributed between both hooks.
5. **BE SURE** the lifting hooks are fully attached to the load and that they cannot become separated from the load. In some cases, it may be necessary to secure the item with safety straps (NOT PROVIDED).
6. **GENTLY** lift the item just above the floor and **STOP**. Re-check the item to ensure the lifting hooks are secure and that the hoist is well attached to the ceiling.
7. **COMPLETE** the lift to the desired position; lock in place by pulling the rope out and up. Securely tie the loose end of the rope to the wall **SAFETY** Tie-Off Cleat.

Lowering

1. **MAKE SURE** no people, pets, or obstructions are under or near the item being lowered.
2. **BEFORE** undoing the rope from the **SAFETY** Tie-Off Cleat, **BE SURE** the locking mechanism is still engaged and holding the item.
3. **UNTIE** rope from the Tie-Off Cleat.
4. **PULL** the rope downward to release the locking mechanism, while maintaining a firm grip on the rope at all times.
5. **GENTLY** lower the item to the ground. **DO NOT** allow the load to free-fall to the ground.
6. **DETACH** the item, and raise the hooks back to the storage position, lock in place, and tie rope to cleat.

INSTRUCTIONS FOR USING THE ACCESSORY STRAPS

The accessory straps are provided to be used where a cradle or wrap is required to adequately attach and lift items such as a ladder, small canoe, etc. **NEVER USE** to lift people, pets or any item that exceeds 120 pounds in total weight.

1. **BE SURE** weight is evenly distributed between the two lifting pulleys.
2. **BEFORE** each lift, fully examine the strap, buckles, and connections. **DO NOT** use if there is any sign of wear or damage. **REPLACE** at once at first sign of wear.
3. **EXTEND** straps.
4. **PLACE** item to be lifted over straps.
5. **ATTACH** straps to lifting hooks by inserting hooks through loops in both ends of the straps.
6. **TIGHTEN** straps so the item is held tightly between the lifting hooks and straps.
7. **AFTER** assuring the item is evenly balanced between the two lifting hooks, gently lift the item just off the ground and **STOP**.
8. **RE-CHECK** the item attachment to ensure it cannot come loose and fall, and complete the lift.

WARNING

DO NOT STEP, CLIMB, OR HANG ON THE STORAGE RACK

DO NOT ALLOW SMALL CHILDREN OR PETS TO PLAY IN, ON, OR AROUND THE STORAGE RACK. IMPROPER INSTALLATION AND/OR USE OF THE STORAGE RACK COULD CAUSE SERIOUS INJURY AND/OR DEATH.

User assumes total responsibility for the proper installation and use of this product. GearUp Inc. will not be held liable for damages or injuries resulting from the installation and/or use of this product. If the installer or user is unsure of the requirements described herein, it is his/her responsibility to seek adequate professional assistance or contact our customer care center at 800-346-7332. **REMEMBER** – stored items can fall resulting in injuries and/or property damage when not properly installed or used.

THANK YOU again for your purchase. We have worked hard to make sure the product you purchased is of top quality and that all parts and necessary instructions have been included. If we have overlooked anything, or if we can be of assistance, help walk you through installation, or offer tips on how to use our product, **PLEASE** give us a call on our **Toll Free Customer Hotline 800-346-7332. YOUR SATISFACTION IS OUR TOP PRIORITY.**

Visit us at our web site www.mygearup.com for other storage solutions and special offerings.